

CTR CC

I. Minimum bending radius

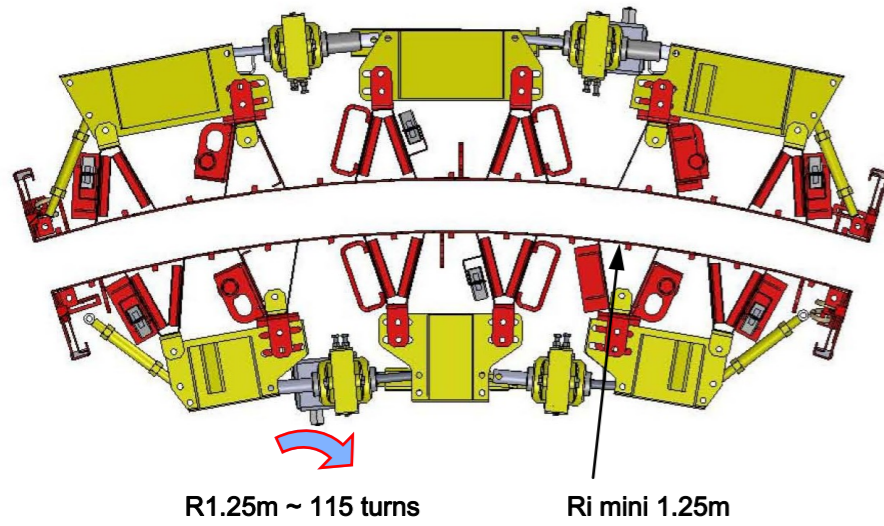

II . Bending height

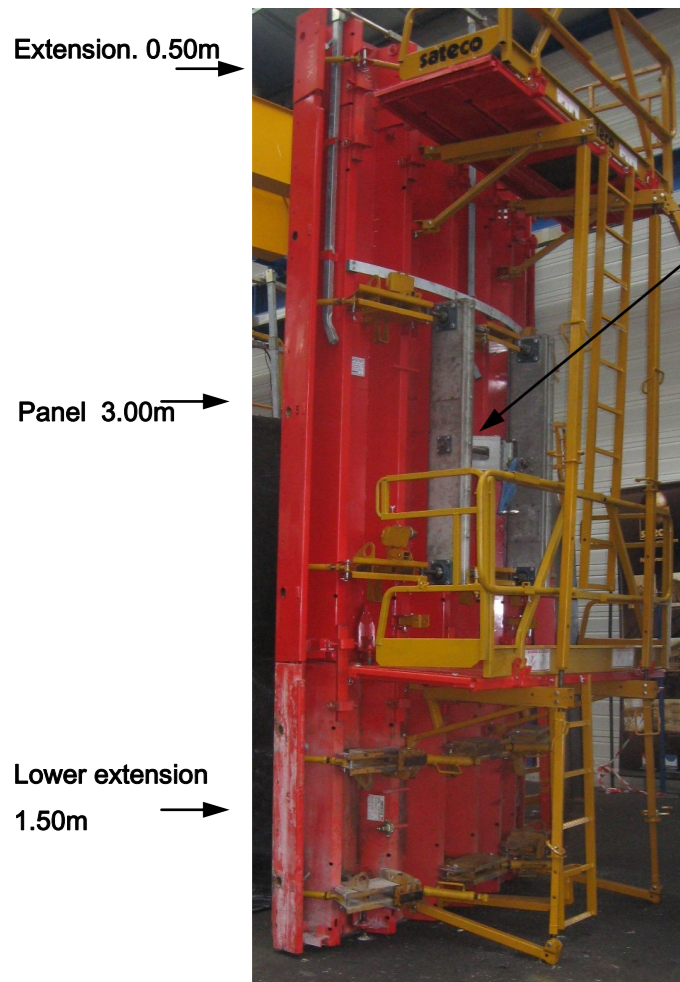

CTR CC

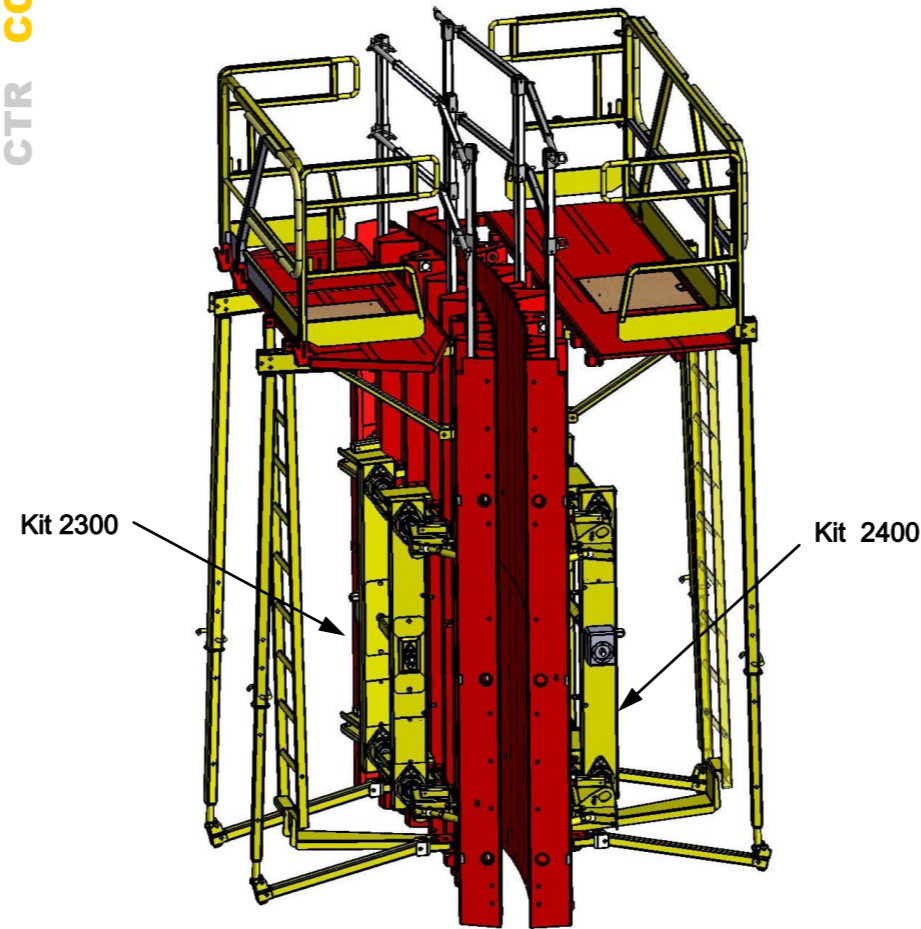

Panels bending

-Bending by means of a **panel element spanner** (stress on the spanner : 10daN/m)

-Possibility to use a **screwing tool**



Bending in 5min (Flat panel at Ri=2.50m)

4'25 panel bending (with the spanner)
0'35 edge adjustment

(9min Ri=1.25m)



NOUS AVONS UN MONDE A BATIR

Registered head office and Production

Zone Industrielle - BP 10 - 86110 Mirebeau - Tél.05 49 50 41 69
Fax : 05 49 50 47 73 - www.sateco-coffrages.com

Directions for use

ASSEMBLING BOOKLET

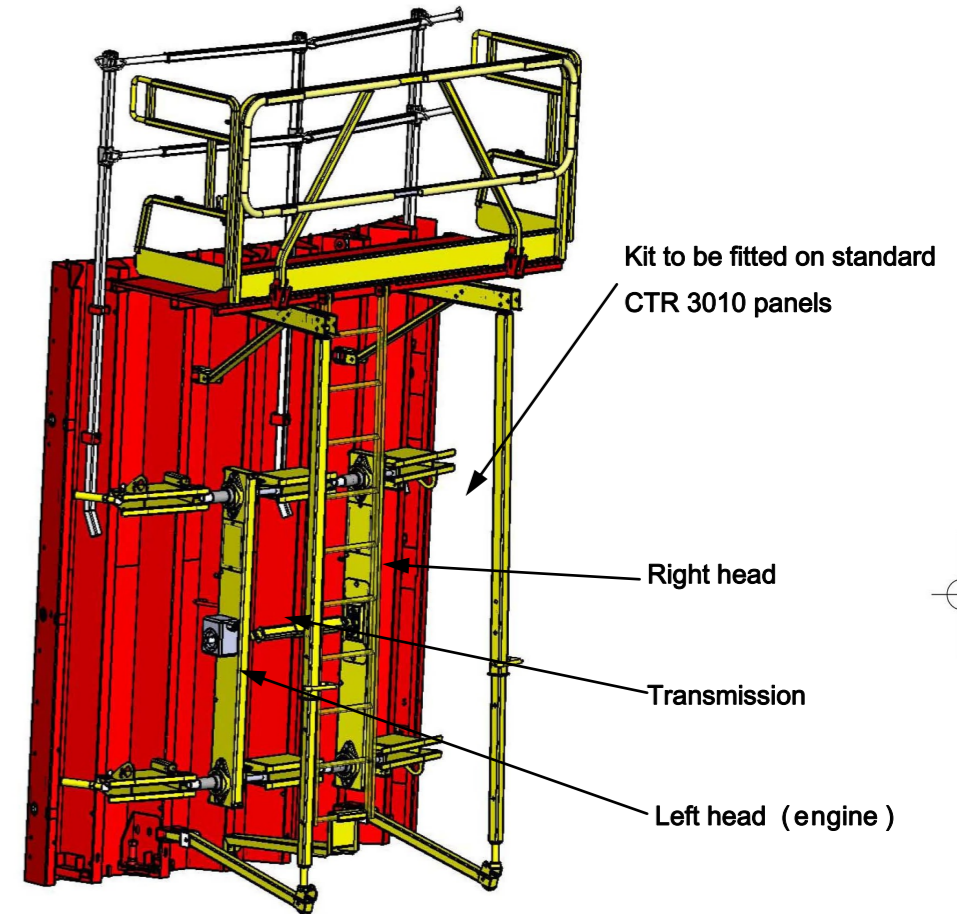

For inner minimum 1.25m radius

**Folding and unfolding,
See CTR 3010 technical documents**

**Permissible loads:
10t./sqm**

INSTRUCTIONS

Réf : FM.02.42.01



Registered head office and Production
Z.I. - BP10 - 86110 MIREBEAU
Tél : (33) 05 49 50 41 69 - Fax : (33) 05 49 50 47 73
www.sateco-coffrages.com - Courriel : cof-com@sateco.fr



ALENOR - 2008 - 05 49 62 69 00 - Edition mois/2008 - Soucieux en permanence de la qualité de ses produits, SATECO se réserve le droit d'en modifier.

Packing

CTR CC

I. Packing

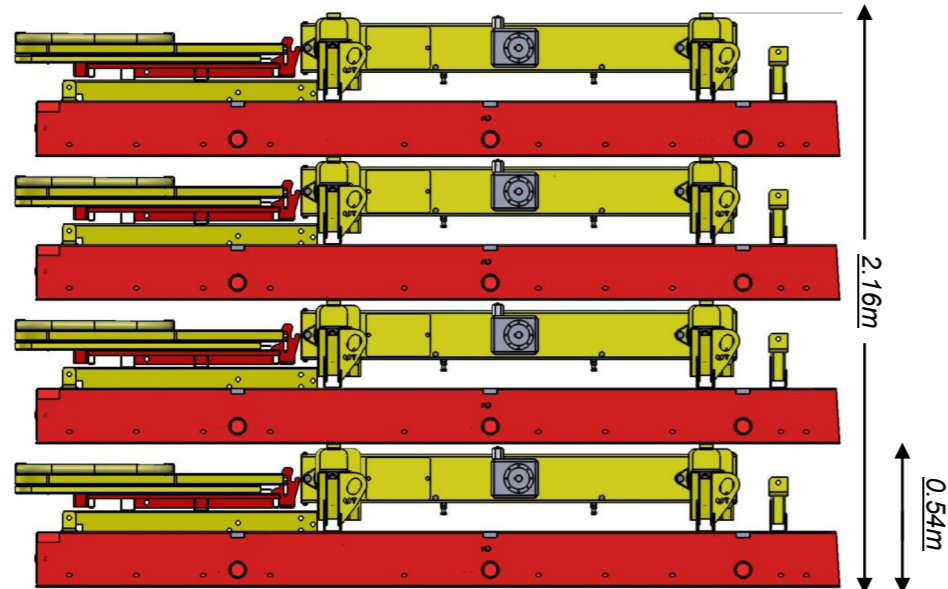

II. Weight

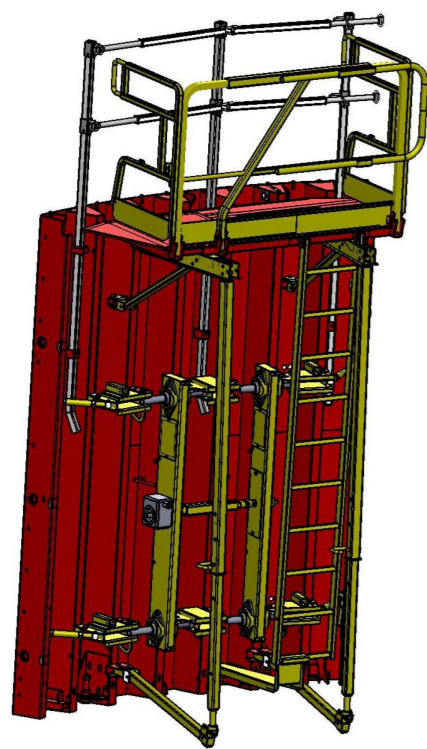

Inner Kit 120kg

Panel 2300 1108kg

(+ 102kg/px std)

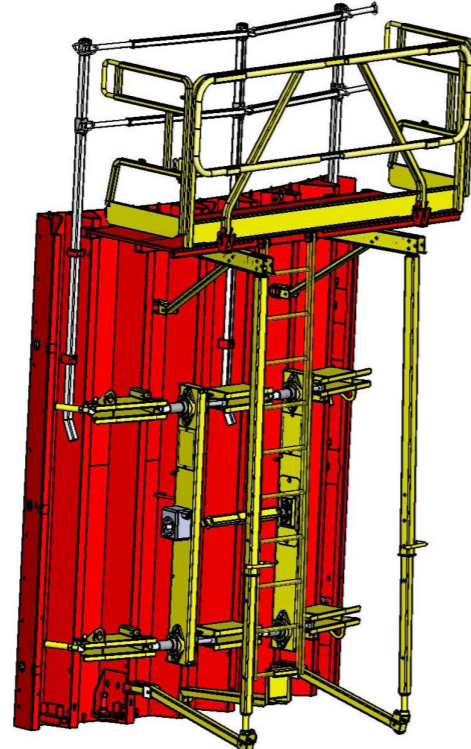

ExTernal Kit 120kg

Panel 2400



Bending

CTR CC

1. Unfold the panel

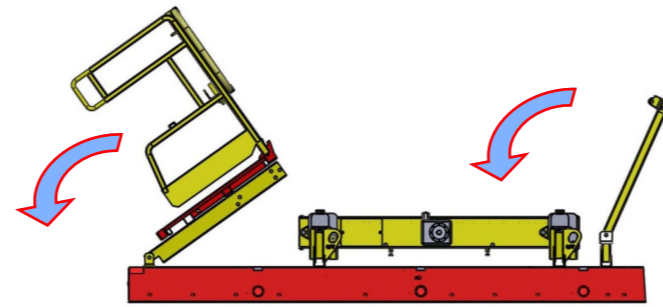

2. Lift up the panel

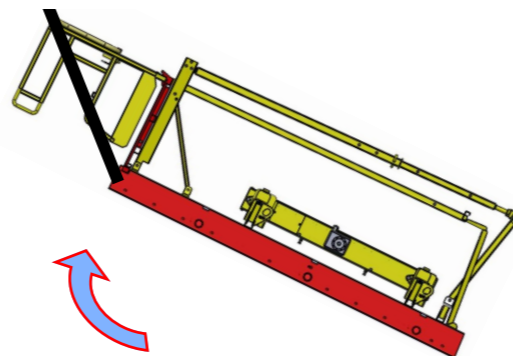

3. Bending

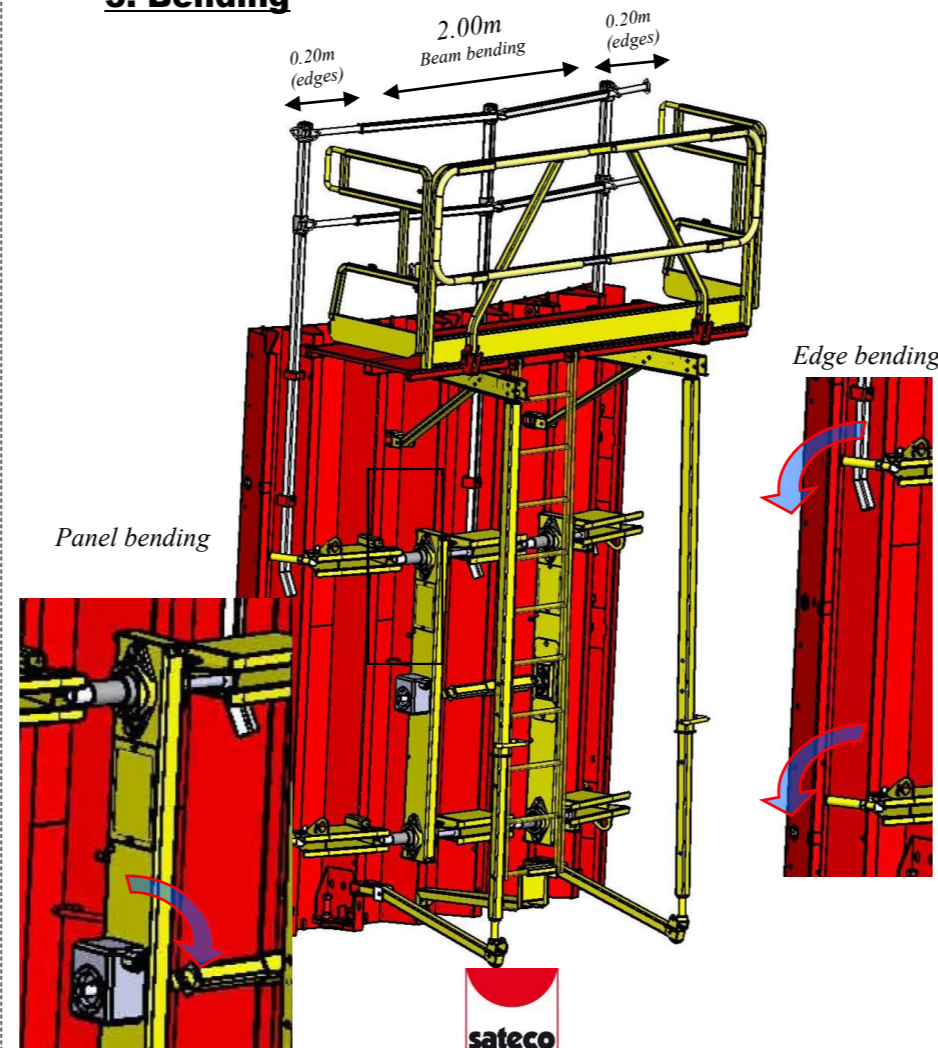

Assembling the Kit

CTR CC

