

RONDA[®]

Circular wall formwork

User guide



Content

1	Product features	3
1.1	General information.....	3
1.2	Safety instructions	3
2	Overview	6
3	Components	7
4	Element dimensions	13
5	Radius adjustment	14
6	Possible radii	16
7	Tying	17
8	Element connection	19
9	Timber adjustment	21
10	Height extension and height adjustment	23
11	Bracing	24
11.1	With the RONDA aligning props	24
11.2	With tubular steel props	24
11.3	With BKS props.....	25
12	Wall connection	26
13	Stopend	26
14	Walkway brackets	27
15	Transportation of elements by crane	29
16	Chronology	31

1 Product features

HÜNNEBECK's RONDA circular formwork is a radius-adjustable circular formwork, which consists of ready-to-use forming elements that can be combined with the MANTO® wall formwork system.

Due to its characteristics, RONDA enables users to work precisely and economically.

The basis for this system is robust ready-to-use elements, which are fitted with a high-quality and ductile 14 mm thick face sheet. With the built-in solid turnbuckles, any desired radius (from 2.75 m) can be adjusted to the millimeter (face sheet until May 1995, 18 mm thick → min. radius 3 m).

With two widths for both the inner and the outer elements, as well as three different heights (3.0 m, 2.0 m, 1.5 m), an optimum adaptability to the given structure is assured.

As a result of the special vertical edge profiles, the edges of the face sheet are protected. All profiles are connected with turnbuckles, which can take either tension or compression forces. The arrangement of the adjusting turnbuckles between the stiffening profiles allows a very low construction height and ensures optimum storage of the RONDA elements.

Fine adjustment of the crane-positioned RONDA elements is achieved by a lever edge at the ends of the stiffened profiles.

The individual elements are connected with the element connectors, which can also be attached with timber infills for length adjustments up to 15 cm. Height extensions can be connected tightly and aligned using the MANTO® aligning panel clamp. Assembled elements with a total area of up to 20 m² can be transferred by crane without the need for additional stiffeners.

1.1 General information

This user guide provides important information about the installation and application of the HÜNNEBECK RONDA circular formwork, as well as precautions which are necessary for safe erection and reliable use. This user guide are intended to enable users to work effectively with the RONDA circular formwork. Please read the user guide carefully prior to erection and use of the RONDA circular formwork and keep them at hand as a reference book.

HÜNNEBECK products are exclusively intended for commercial use by technically qualified users.

1.2 Safety instructions

Important information regarding the intended use and safe application of formwork and falsework.

The contractor is responsible for drawing up a comprehensive risk assessment and a set of installation instructions. The latter is not usually identical to the user guide.

- Risk assessment
The contractor is responsible for the compilation, documentation, implementation and revision of a risk assessment for each construction site. His employees are obliged to implement the measures resulting from this in accordance with all legal requirements.
- Installation instructions
The contractor is responsible for compiling a written set of installation instructions. The user guide forms part of the basis for the compilation of a set of installation instructions.

- **User guide**

Formwork is technical work equipment which is intended for commercial use only. The intended use must take place exclusively through properly trained personnel and appropriately qualified supervisory personnel. The user guide is an integral component of the formwork construction. It comprises at least safety guidelines, details of the standard configuration and intended use, as well as the system description. This user guide is intended for commercial users with appropriate technical training. The contents and processes described are in accordance with the legal and occupational safety regulations of Germany and Austria. HÜNNEBECK assumes no liability for deviations from the contents and processes described or for use outside this area of application. The functional instructions (standard configuration) contained in the user guide are to be complied with as stated. Enhancements, deviations or changes represent a potential risk and therefore require separate verification (with the help of a risk assessment) or a set of installation instructions which comply with the relevant laws, standards and safety regulations. The same applies in those cases where formwork and/or falsework components are provided by the contractor.
- **Availability of the user guide**

The contractor has to ensure that the user guide provided by the manufacturer or formwork supplier is available at the place of use. Site personnel are to be informed of this before assembly and use takes place, and that it is available at all times.
- **Representations**

The representations shown in the user guide are, in part, situations of assembly and not always complete in terms of safety considerations. Any necessary safety installations that have not been shown in these representations must nevertheless be available.
- **Storage and transportation**

The special requirements of the respective formwork constructions regarding transportation procedures as well as storage must be complied with. By way of example, name the appropriate lifting gear to be used.
- **Material check**

Formwork and falsework material deliveries are to be checked on arrival at the construction site/place of destination as well as before each use to ensure that they are in perfect condition and function correctly. Changes to the formwork materials are not permitted.
- **Spare parts and repairs**

Only original components may be used as spare parts. Repairs are to be carried out by the manufacturer or authorized repair facilities only.
- **Use of other products**

Combining formwork components from different manufacturers carries certain risks. They are to be individually verified and can result in the compilation of a separate set of assembly instructions required for the installation of the equipment.

- Safety symbols
Individual safety symbols are to be complied with.

Examples:

 DANGER	DANGER! DANGER indicates a hazardous situation which, if not avoided, will result in death or serious injury.
---	---

 WARNING	WARNING! WARNING indicates a hazardous situation which, if not avoided, could result in death or serious injury.
--	--

 CAUTION	CAUTION! CAUTION used with the safety alert symbol indicates a hazardous situation which, if not avoided, could result in minor or moderate injury.
--	---

NOTE	NOTE NOTE refers to practices not related to personal injury.
-------------	---

 VISUAL CHECK	VISUAL CHECK refers to a visual check and is not related to personal injury.
---	--

- Miscellaneous
Technical improvements and modifications are subject to change without notice.
For the safety-related application and use of the products, all current country-specific laws, standards, as well as other safety regulations are to be complied with without exception. They form a part of the obligations of employers and employees regarding industrial safety. This results in, among other things, the responsibility of the contractor to ensure the stability of the formwork and falsework constructions, as well as the structure during all stages of construction.
This also includes the basic assembly, dismantling and the transportation of the formwork and falsework constructions or their components. The complete construction is to be checked during and after assembly.



Copyright: Güteschutzverband Betonschalungen e.V.
Postfach 10 44 61
40855 Ratingen
GERMANY

2 Overview

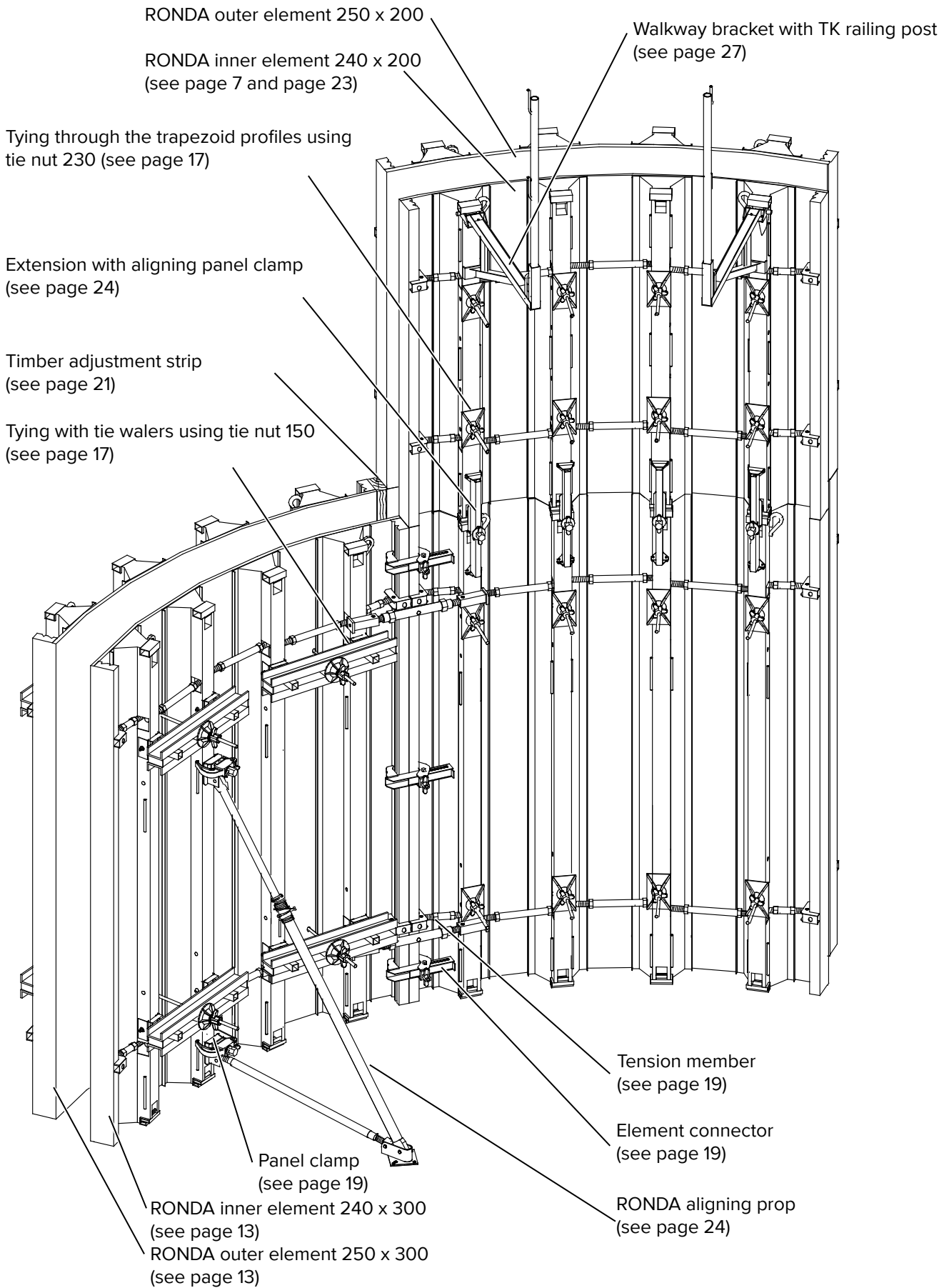





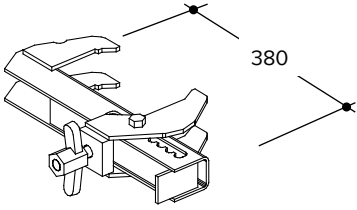
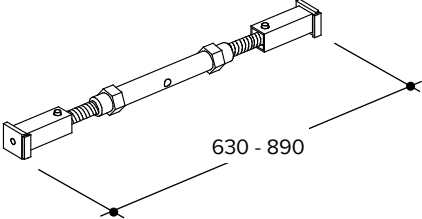
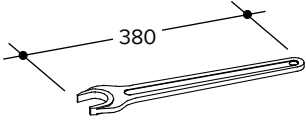
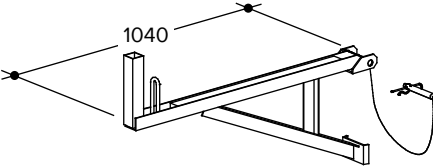
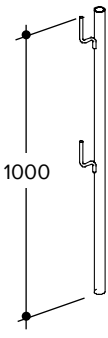
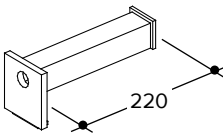
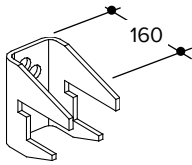

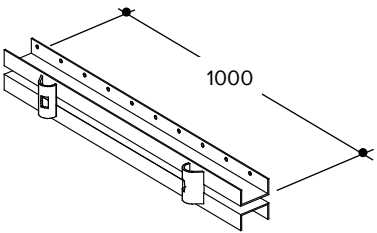
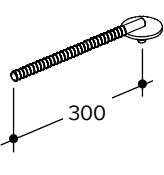
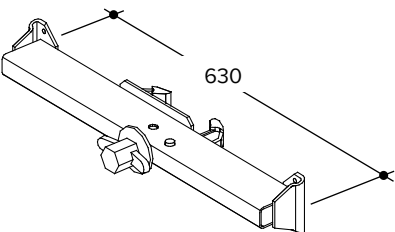
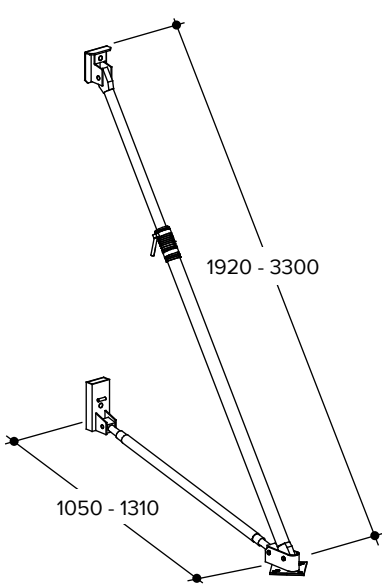
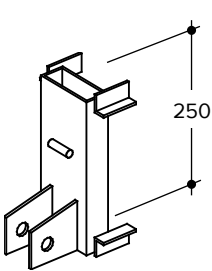
3 Components

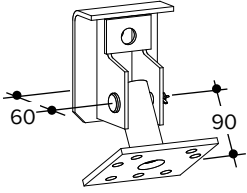
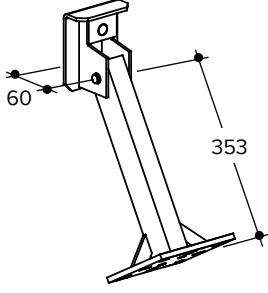
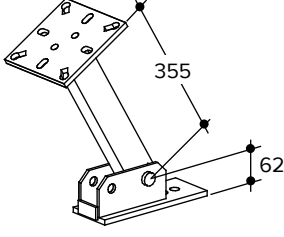
	Component	Product code	Weight [kg]
	RONDA outer element 250 x 300	529600	367.17
	RONDA outer element 128 x 300	529610	213.79
	RONDA inner element 240 x 300	529621	362.69
	RONDA inner element 123 x 300	529632	211.53
	RONDA outer element 250 x 200	529643	264.17
	RONDA outer element 128 x 200	529654	153.17
	RONDA inner element 240 x 200	529665	260.59
	RONDA inner element 123 x 200	529676	150.87
	RONDA outer element 250 x 150	529687	190.85
	RONDA outer element 128 x 150	529698	111.17
	RONDA inner element 240 x 150	529702	188.61
	RONDA inner element 123 x 150	529713	110.14
	<p>The 14 mm thick face sheet is supported by hot-dip galvanized stiffening profiles. The required radius (starting from 2.75 m) is adjusted with turnbuckles, which are designed for tension and compression loads. Each formwork element is equipped with crane eyes to transport it and a lever edge for fine adjustment on the ground.</p>		
	Tie waler	524949	24.16
	<p>Distributes the tie load onto 2 neighboring trapezoid profiles. Bolts and spring pins are captived and cannot be lost.</p>		

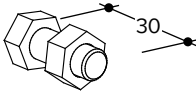
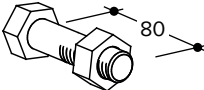
	Component	Product code	Weight [kg]
	<p>Element connector Used for the connection of elements. Can also be applied with timber infills up to 15 cm.</p>	526000	5.50
	<p>Tension member Used for overlapping the panel joint of the inner formwork when exceeding radii of more than 10.0 m. The tension member has to be installed on the trapezoid profiles at the level of the turnbuckles.</p>	548387	7.15
	<p>Open-jawed spanner (w.a.f. 46) Facilitates the operation of turnbuckles.</p>	542460	0.78
	<p>Walkway bracket Is attached to the trapezoid profile and secured with the captive bolt.</p>	524950	13.30
	<p>TK railing post Is inserted into the walkway bracket, serves as support for railing boards and is provided by site.</p>	193220	4.50
	<p>Head tie pocket Serves as guiding device when placing a tie rod directly above the formwork element. Permitted load = 12 kN (DW 15)</p>	526547	1.40
	<p>Edge tie fastener MR Used for gridless tying outside the formwork panels. For tie rods DW 15. Permitted load = 10 kN</p>	566667	2.40

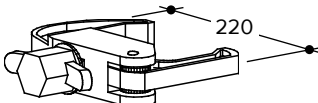
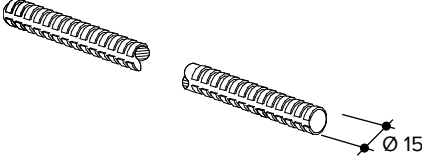
	Component	Product code	Weight [kg]
	<p>Multi purpose waler 100</p> <p>Used for stopends. Fastened to the elements with two waler spanners and two tension nuts.</p>	450764	13.10
	<p>Waler spanner (30 cm)</p> <p>Required to fasten the multi purpose waler 100. (Order two parts for each waler.)</p>	452053	0.76
	<p>Aligning panel clamp</p> <p>Connects height-extended formwork elements and must be attached to each stiffening trapezoid profile.</p>	448000	5.50
	<p>RONDA aligning prop</p> <p>Used for aligning and supporting the formwork. Applicable to formwork heights of up to 4.5 m at a horizontal spacing of maximum 2.5 m. The aligning prop has to be connected to the trapezoid profiles by using 2 panel clamps.</p> <p>Permitted load: 8 kN at maximum extension.</p>	453070	25.60
	<p>RONDA BKS</p> <p>For connecting BKS aligning struts or similar aligning props when bracing greater formwork heights. For this connection order additionally:</p> <p>2 x panel clamps + 1 x bolt M20 x 80 with nut</p>	533138	3.08

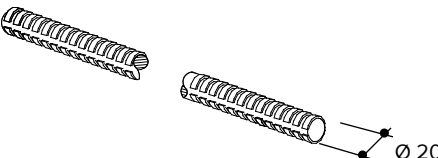
	Component	Product code	Weight [kg]
	RONDA prop adapter	453080	3.38
	RONDA prop adapter new	601622	6.76
	Strut base	566369	7.70
	<p>Standard steel props can be applied as inclined props by using these parts. Each steel prop connection requires 4 bolts + nuts M12 x 30 (product code: 005210) on the top plate and base plate. A counter nut A, AS or 400 EC/550 DC (according to prop type) makes the prop tensile-proof. The RONDA prop adapter is attached to the RONDA elements with a panel clamp.</p> <p>To be ordered additionally:</p> <p>Steel prop Bolt + nut M12 x 30 (8 x per prop) Counter nut (1 x per prop) Choose counter nut according to prop type.</p> <p>The strut base is used to transfer loads into capable ground.</p>		
	<p>Steel prop EUROPLUSnew® 20-250</p> <p>Steel prop EUROPLUSnew® 20-300</p> <p>Steel prop EUROPLUSnew® 20-350</p> <p>Steel prop EUROPLUSnew® 20-400</p> <p>Steel prop EUROPLUSnew® 20-550</p>	<p>601390</p> <p>601400</p> <p>601410</p> <p>601415</p> <p>601425</p>	<p>13.15</p> <p>16.82</p> <p>20.52</p> <p>23.79</p> <p>36.07</p>
	<p>Steel prop EUROPLUSnew® 30-150</p> <p>Steel prop EUROPLUSnew® 30-250</p> <p>Steel prop EUROPLUSnew® 30-300</p> <p>Steel prop EUROPLUSnew® 30-350</p> <p>Steel prop EUROPLUSnew® 30-400</p>	<p>601460</p> <p>601430</p> <p>601440</p> <p>601445</p> <p>601450</p>	<p>10.68</p> <p>16.19</p> <p>19.17</p> <p>24.24</p> <p>28.75</p>
	<p>Bolt M12x30 with nut (8 pcs. required per prop)</p>	5210	0.06
	Bolt M20x80 with nut	489801	0.36

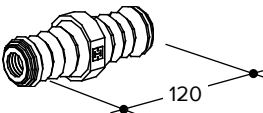
	Component	Product code	Weight [kg]
	Panel clamp For the connection of all bracings to the RONDA formwork.	448010	3.01
	Tie rod 100 (DW 15) Tie rod 130 (DW 15) Permitted load acc. to DIN 18216 < 90 kN.	24387 20481	1.44 1.87
	WARNING	Warning! Do not weld or heat tie rods because they may suddenly fail!	
	Tie rod 100 (DW 20) Tie rod 130 (DW 20) Permitted load acc. to DIN 18216 < 150 kN.	531600 531610	2.56 3.33
	WARNING	Warning! Do not weld or heat tie rods because they may suddenly fail!	
	The following counter nuts are required for the props listed below.		
	Counter nut A / 260 DB / 300 DB (for EUROPLUSnew®: 20-250, 20-300, 30-150, as well as for EUROPLUS® props 260 DB and 300 DB)	107107	0.92
	Counter nut AS / 350 DB / 410 DB (for EUROPLUSnew® 20-350, 20-400, 30-250, 30-300 and 30-350, as well as for EUROPLUS® props 350 DB)	107118	1.00
	Counter nut 400 EC / 550 DC (for EUROPLUSnew® 20-550, 30-400, as well as for EUROPLUS® props 400 EC and 550 DC)	587675	1.39
	Counter nut 350 EC / 450 DB (for EUROPLUS® props 350 EC and 450 DB)	562051	1.50
	Each prop requires one counter nut.		
	Water stop 15 Is used for waterproof anchoring (DW 15). Lost part.	164400	0.55

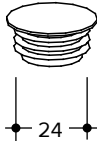
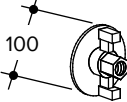
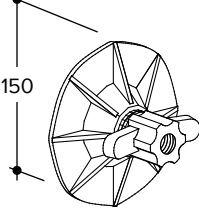
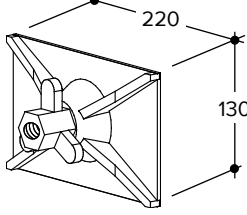
	Component	Product code	Weight [kg]
	<p>100 Plugs 24-27 For sealing of tie holes which are not used. 100 pcs./ packet.</p>	581483	0.40
	<p>Tension nut ≤ (DW 15) Order one part for each waler spanner. Permitted load = 40 kN</p>	197332	0.65
	<p>Tie nut 150 (DW 20) Has to be put in when using tie walers and with higher concrete pressure.</p>	531481	1.51
	<p>Tie nut 230 (DW 15) Has to be used when tying directly through the trapezoid profiles, because of its large supporting area.</p>	48344	2.40

4 Element dimensions

Outer element 250

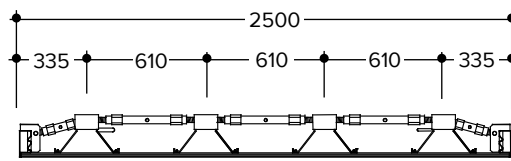

Outer element 128

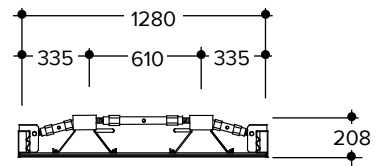
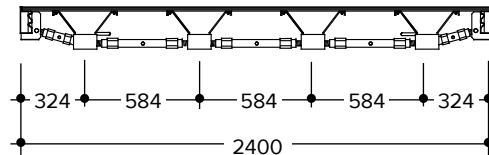
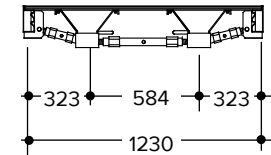

Fig. 2



Inner element 240

Fig. 3



Inner element 123

Drill hole for tying through the trapezoid profile (only in trapezoid profile, the face sheet has to be drilled separately).

Drill hole for tying via tie waler (standard)

Fig. 4

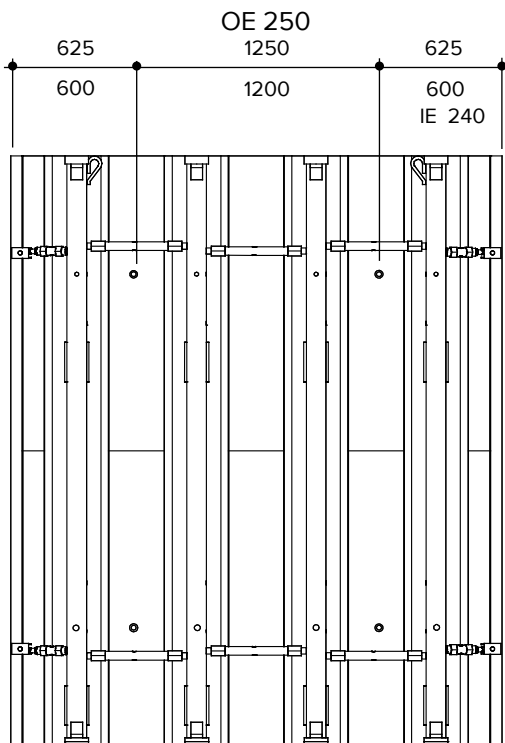

Fig. 5

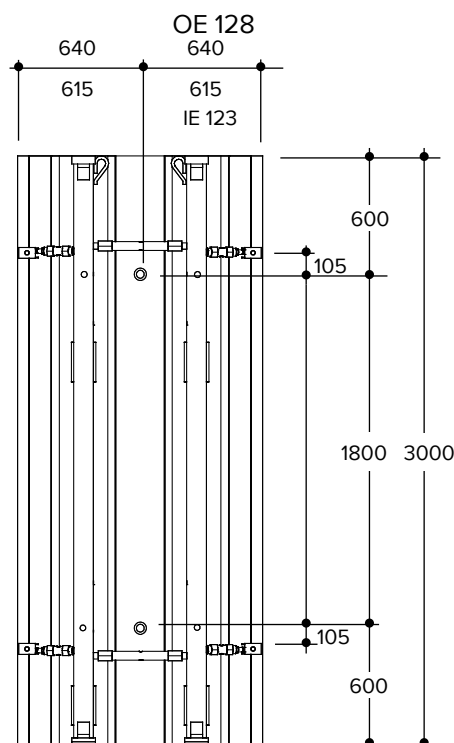
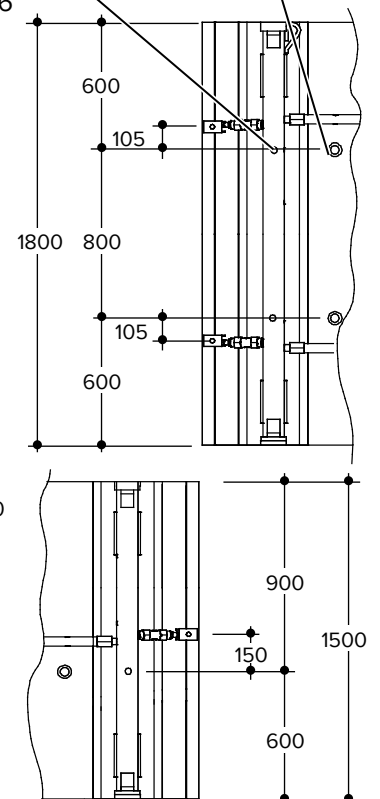

Fig. 6



5 Radius adjustment

Preparation

The RONDA elements, which are delivered to the jobsite as plane elements, must be placed onto two assembling trestles by crane for the adjustment of radii. The supporting main beams of the trestles must be arranged parallel, as shown, to the trapezoid profiles of the RONDA elements.

The adjustment is done by two people to ensure even adjustment of the upper and lower turnbuckles at the same time. The turnbuckles are adjusted with a spanner (w.a.f. 46) or by using a round bar $< \varnothing 18$ mm (e.g. tie rod). The adjustment is checked by using a precisely fabricated radius gauge with a length of > 2.5 m, made of distortion-free timber or plywood provided on site. The inner and outer elements require different gauges. In order to check the adjustment with the radius gauges continually, the supporting main beams of the trestles must be shorter than the RONDA element.

Fig. 7-1

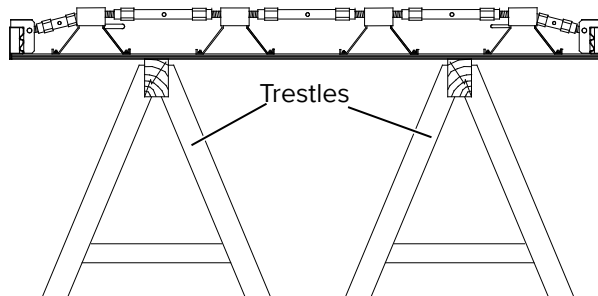
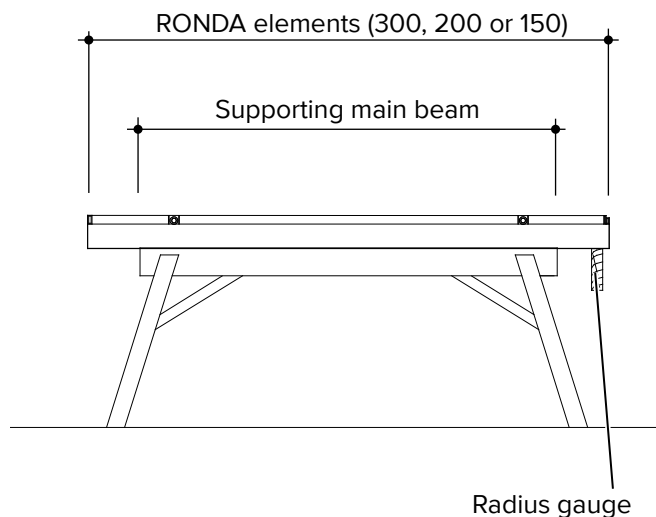

Fig. 7-2



VISUAL CHECK

In order to achieve an even radius with extended elements, connect the elements before adjusting the radius (see page 19).

Adjustment procedure

First, screw all turnbuckles up manually to fit tightly without clearance. Then, adjust the curve evenly on both sides, step by step. Operate the turnbuckles according to the numbered work steps in figure 7-3 or 7-4. During this work step, turn the inner turnbuckles (1 to 3) a half revolution and the two outer turnbuckles (4 + 5) only a quarter revolution. Both rows of turnbuckles must be rotated simultaneously. Repeat this work step until the curve of the RONDA element is the same as the curve of the gauge. The adjusted and ready-to-use RONDA element is lifted by crane with the two crane eyes from the trestles and transported to the place of use or another place for temporary storage.

Fig. 7-3

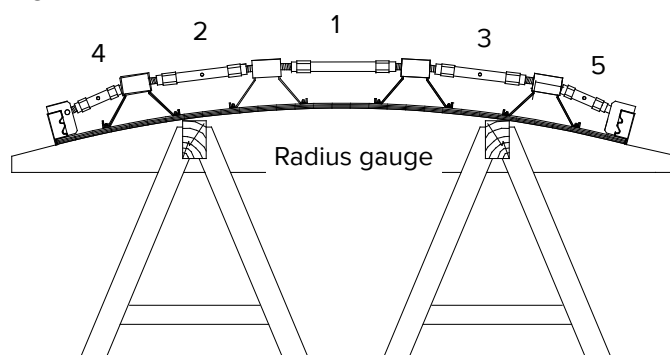

VISUAL CHECK

During turning of the turnbuckles the radius must be checked. This control must always be carried out on the face sheet side.

Adjustment of upright elements

Generally, all RONDA elements can also be adjusted to the relevant radii in an upright (standing) position. The adjustment procedure is the same as described before. Nevertheless, in this case safety issues must be observed closely.

Fig. 7-4

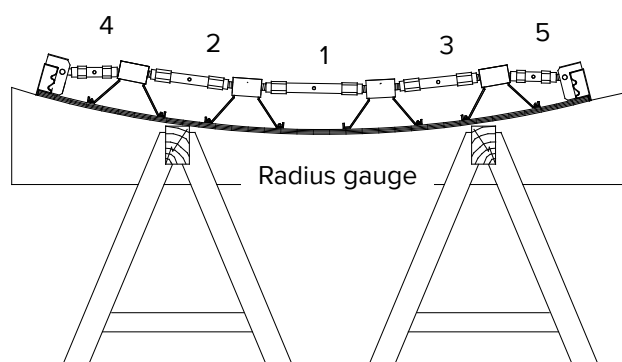

WARNING

Warning!

During works on these RONDA formwork elements, the elements must be supported sufficiently or secured in another way against falling. The trestles must be suitable and sufficiently stable.

6 Possible radii



WARNING

Warning!

With radii larger than 35 m, special measures are necessary in order to adhere to the tolerances.

Minimum radius

$$R_{\min} = 2.75 \text{ m}$$

For RONDA elements with 14 mm face sheet and a max. concrete pressure of 40 kN/m².

Minimum radius

$$R_{\min} = 3.00 \text{ m}$$

For RONDA elements with 18 mm face sheet (until 1995) and a max. concrete pressure of 40 kN/m².

Minimum radius

$$R_{\min} = 4.00 \text{ m}$$

For RONDA elements with 14 mm face sheet and a max. concrete pressure of 60 kN/m².

Fig. 8

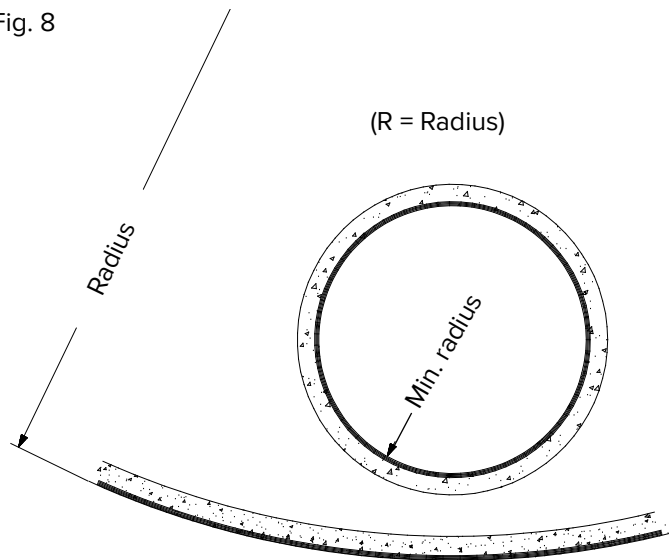

Maximum radius

$$R_{\max} = 35.0 \text{ m}$$

For RONDA elements produced since 4/1994, identifiable by the version of turnbuckle as shown in Fig. 9.

Fig. 9

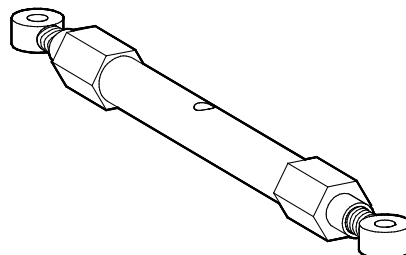

Maximum radius

$R_{max} = 25.0 \text{ m}$

For RONDA elements produced until 4/1994, identifiable by the version of turnbuckle as shown in Fig. 10.

Fig. 10

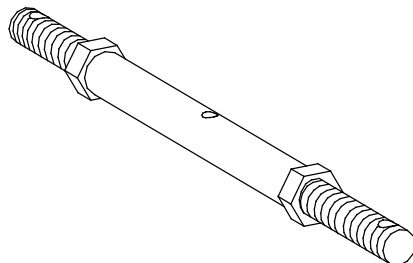

NOTE

Note

Regular cleaning and greasing of the turnbuckles facilitates future adjustment procedures!

7 Tying

For the tying of RONDA circular formwork, you can either use tie walers or the holes in the trapezoid profiles. When using tie walers with the RONDA elements, you will save every second wall tie. For that economic reason the RONDA elements come already equipped with these relevant tie holes.

With tie waler

Fig. 11-1

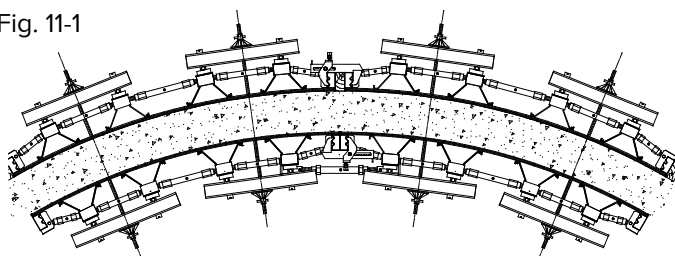
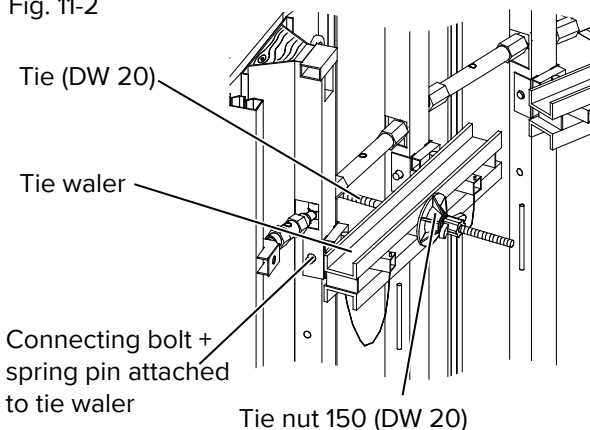

Fig. 11-2



WARNING

Warning!

The use of 20 mm thick tie rods is absolutely necessary when assuming a concrete pressure higher than 50 kN/m^2 , due to the large surface area per wall tie!

When tying through the holes in the middle of each trapezoid profile, the face sheet must be drilled at the relevant positions on site with $\varnothing 24$ mm. All trapezoid profiles are already provided with tie holes which mark the holes in the face sheet.

Without tie waler

Fig. 12

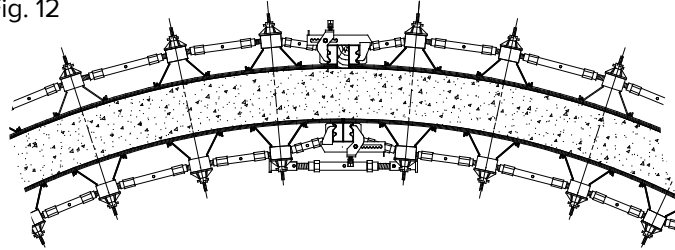
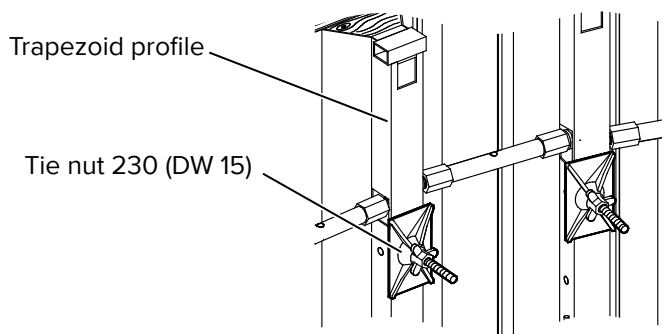

Fig. 13



NOTE

Note

When tying is executed directly through the trapezoid profiles, the large tie nut 230 has to be used.

The positions of the ties are already predefined by the factory-made holes in the face sheet or in the trapezoid profiles. But it is possible to displace the top tying spot by using the head tie pocket. The 1.50 m high RONDA elements must always be applied with the head tie pocket at the top (Fig. 14).

Fig. 14

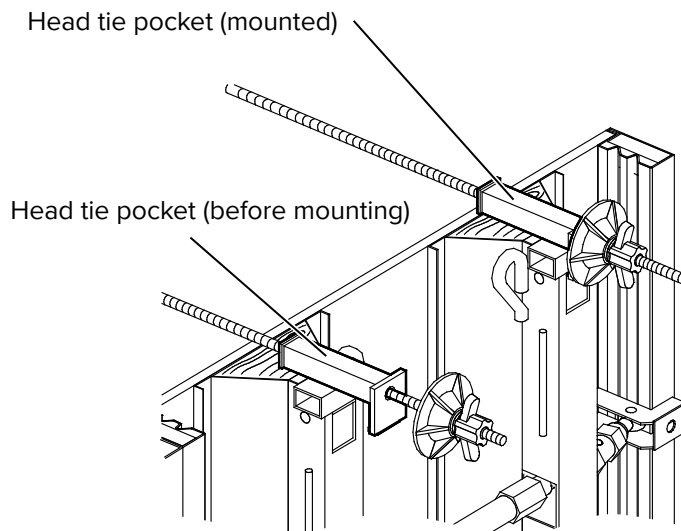

In case of height extension with 1.50 m high RONDA elements, the upper tie can be omitted (Fig. 14-1).

Fig. 14-1

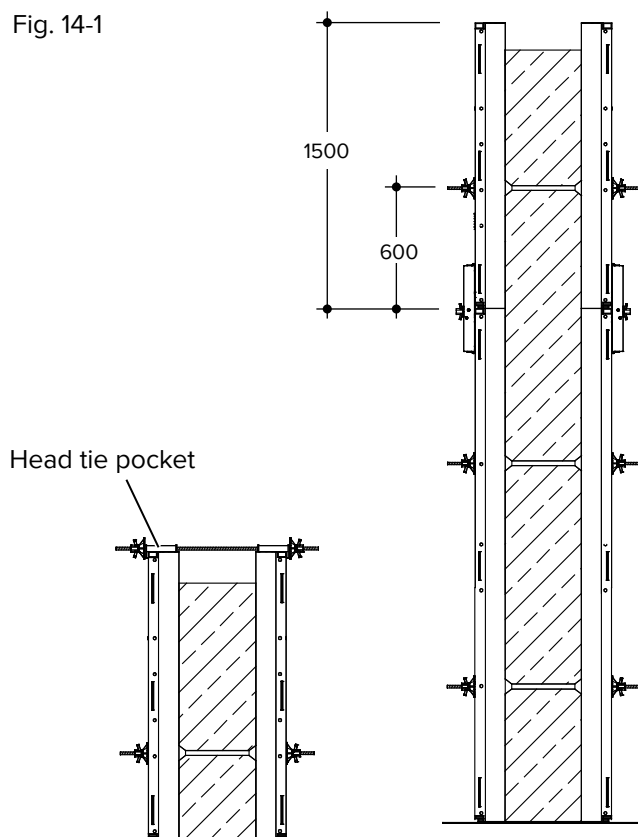

8 Element connection

The RONDA elements are connected at the vertical joint by using element connectors which can be positioned at any height on the edge profiles. One element connector has to be used for each linear meter of vertical joint (e.g. 5 element connector at a formwork height of 4.5 m). The element connector can connect elements without or with timber adjustments of up to 15 cm. For fatigue-proof and almost free-from-wear tightening and releasing of the element connector is recommended to use the MANTO® ratchet (product code: 408780).

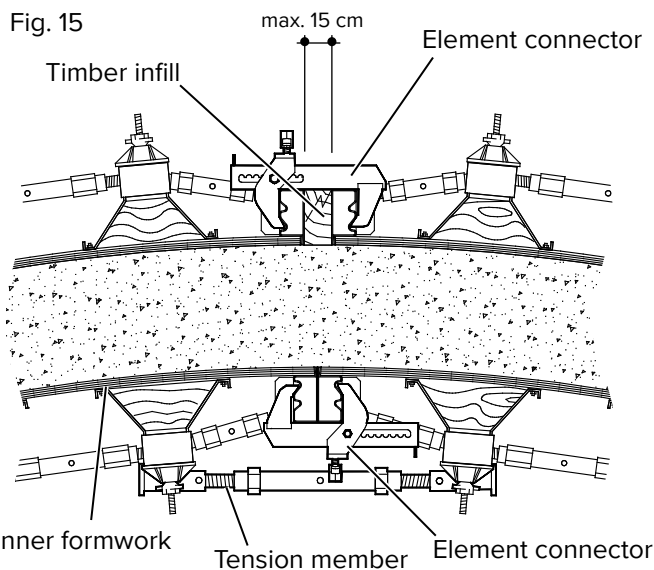

The element joints of the inner formwork with radii >10.0 m must be equipped with tension members on every row of turnbuckles. The crooked ends of the tension members are inserted into the openings on the side of the trapezoid profiles. Tighten the spindle tube to a tight seat without any clearance by hand.

Fig. 16

Row of turnbuckles of the RONDA element

Tension member

Element connector

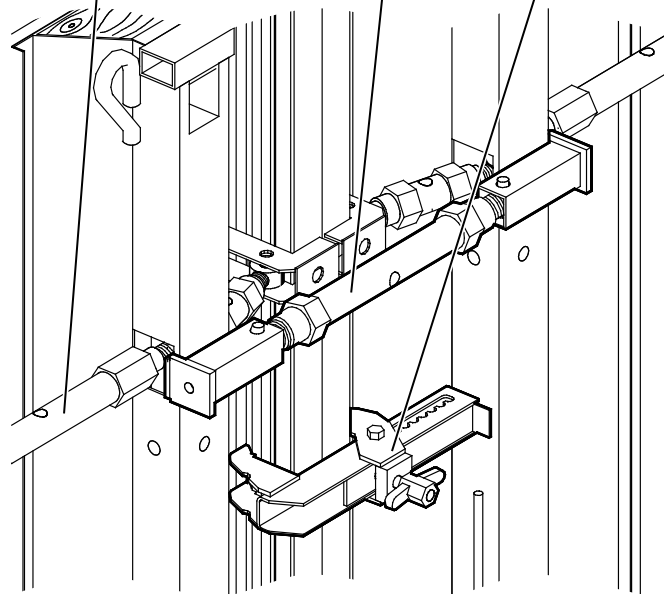

WARNING

Warning!

Strong tightening of the spindles may cause damages.

9 Timber adjustment

The exact adjustment of the RONDA elements to the radius and the wall thickness is made by using timber adjustments in the panel joints. Adaptation to the exact measurement may be necessary within the inner and/or outer formwork. Timber adjustments of the outer formwork are marked in the table by a minussign (for example -6.0 cm). Adjustment widths for radii and wall thicknesses that are not contained in the table have to be calculated either according to the given formulas or must be found by interpolation. As a rule, in complete circles, timber adjustments in the inner and outer formwork are always necessary!

Adjustment width = A

Fig. 17

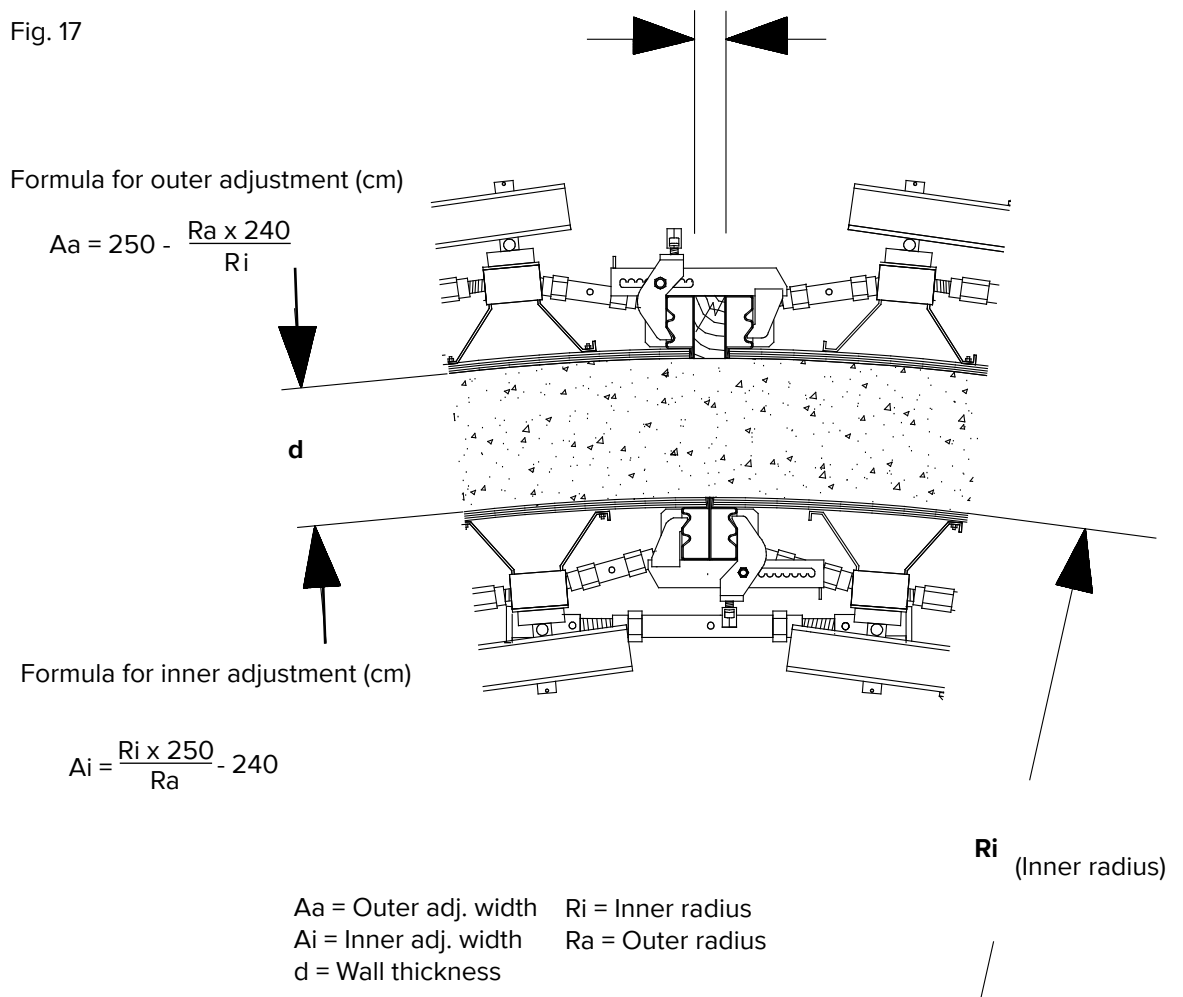

Timber adjustment

Timber adjustment widths [cm]

The adjustment widths shown in the table are not valid for a complete circle.

Ri = Inner radius [cm]	d = Thickness of concrete wall [cm]													
	10	15	20	25	30	35	40	45	50	55	60	65	70	75
275	1.2	-3.1	-7.5	-11.8										
400	3.9	1.0	-2.0	-5.0	-8.0	-11.0	-14.0							
500	5.1	2.7	0.4	-2.0	-4.4	-6.8	-9.2	-11.6	-14.0					
600	5.9	3.9	1.9	-	-2.0	-4.0	-6.0	-8.0	-10.0	-12.0	-14.0			
700	6.5	4.8	3.1	1.4	-0.3	-2.0	-3.7	-5.4	-7.1	-8.9	-10.6	-12.3	-14.0	
800	6.9	5.4	3.9	2.4	1.0	-0.5	-2.0	-3.5	-5.0	-6.5	-8.0	-9.5	-11.0	-12.5
900	7.3	5.9	4.6	3.2	1.9	0.6	-0.7	-2.0	-3.3	-4.7	-6.0	-7.3	-8.7	-10.0
100	7.5	6.3	5.1	3.9	2.7	1.5	0.4	-0.8	-2.0	-3.2	-4.4	-5.6	-6.8	-8.0
1100	7.7	6.6	5.5	4.4	3.4	2.3	1.2	0.2	-0.9	-2.0	-3.1	-4.2	-5.3	-6.4
1200	7.9	6.9	5.9	4.9	3.9	2.9	1.9	1.0	-	-1.0	-2.0	-3.0	-4.0	-5.0
1300	8.1	7.1	6.2	5.3	4.4	3.4	2.5	1.6	0.7	-0.2	-1.1	-2.0	-2.9	-3.8
1400	8.2	7.3	6.5	5.6	4.8	3.9	3.1	2.2	1.4	0.5	-0.3	-1.1	-2.0	-2.9
1500	8.3	7.5	6.7	5.9	5.1	4.3	3.5	2.7	1.9	1.2	0.4	-0.4	-1.2	-2.0
1600	8.4	7.7	6.9	6.2	5.4	4.6	3.9	3.2	2.4	1.7	1.0	0.2	-0.5	-1.3
1700	8.5	7.8	7.1	6.4	5.7	5.0	4.3	3.6	2.9	2.2	1.5	0.8	0.1	-0.6
1800	8.6	7.9	7.3	6.6	5.9	5.2	4.6	3.9	3.2	2.6	1.9	1.3	0.6	-
1900	8.7	8.0	7.4	6.8	6.1	5.5	4.8	4.2	3.6	3.0	2.3	1.7	1.1	0.5
2000	8.8	8.1	7.5	6.9	6.3	5.7	5.1	4.5	3.9	3.3	2.7	2.1	1.5	1.0
2100	8.8	8.2	7.6	7.1	6.5	5.9	5.3	4.8	4.2	3.6	3.1	2.5	1.9	1.4
2200	8.9	8.3	7.7	7.2	6.6	6.1	5.5	5.0	4.4	3.9	3.4	2.8	2.3	1.8
2300	8.9	8.4	7.8	7.3	6.8	6.3	5.7	5.2	4.7	4.2	3.6	3.1	2.6	2.1
2400	9.0	8.4	7.9	7.4	6.9	6.4	5.9	5.4	4.9	4.4	3.9	3.4	2.9	2.4
2500	9.0	8.5	8.0	7.5	7.0	6.5	6.1	5.6	5.1	4.6	4.1	3.7	3.2	2.7
2600	9.0	8.6	8.1	7.6	7.1	6.7	6.2	5.7	5.3	4.8	4.4	3.9	3.4	3.0
2700	9.1	8.6	8.2	7.7	7.3	6.8	6.4	5.9	5.5	5.0	4.6	4.1	3.7	3.2
2800	9.1	8.7	8.2	7.8	7.3	6.9	6.5	6.0	5.6	5.2	4.8	4.3	3.9	3.5
2900	9.1	8.7	8.3	7.9	7.4	7.0	6.6	6.2	5.8	5.3	4.9	4.5	4.1	3.7
3000	9.2	8.8	8.3	7.9	7.5	7.1	6.7	6.3	5.9	5.5	5.1	4.7	4.3	3.9
3100	9.2	8.8	8.4	8.0	7.6	7.2	6.8	6.4	6.0	5.6	5.3	4.9	4.5	4.1
3200	9.2	8.8	8.4	8.1	7.7	7.3	6.9	6.5	6.2	5.8	5.4	5.0	4.6	4.3
3300	9.2	8.9	8.5	8.1	7.7	7.4	7.0	6.6	6.3	5.9	5.5	5.2	4.8	4.4
3400	9.3	8.9	8.5	8.2	7.8	7.5	7.1	6.7	6.4	6.0	5.7	5.3	5.0	4.6
3500	9.3	8.9	8.6	8.2	7.9	7.5	7.2	6.8	6.5	6.1	5.8	5.4	5.1	4.8

10 Height extension and height adjustment

Three different element heights (1.5 m, 2.0 m, 3.0 m) of the RONDA circular formwork are available for adapting the concrete structure to the required height. The elements can be combined in steps of 50 cm. Only elements with identical widths can be extended!

The one-piece MANTO® aligning panel clamp is used for the connection of elements at the horizontal element joints. Generally, one aligning panel clamp has to be positioned on every trapezoid profile. The claws of the MANTO® aligning panel clamp mesh into the reinforced ends of the trapezoid profiles. By tightening the wing nut with the MANTO® ratchet, the RONDA elements are adjusted tensile-proof and aligned.

Fig. 18

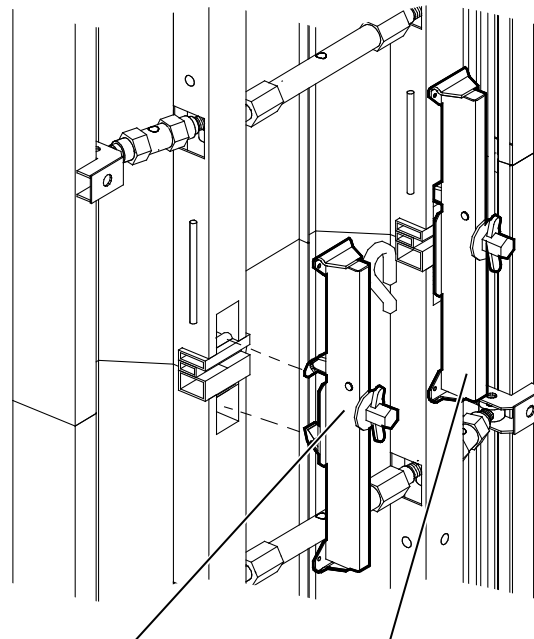

Aligning panel clamp before attachment

Aligning panel clamp already in final position

Fig. 18-1

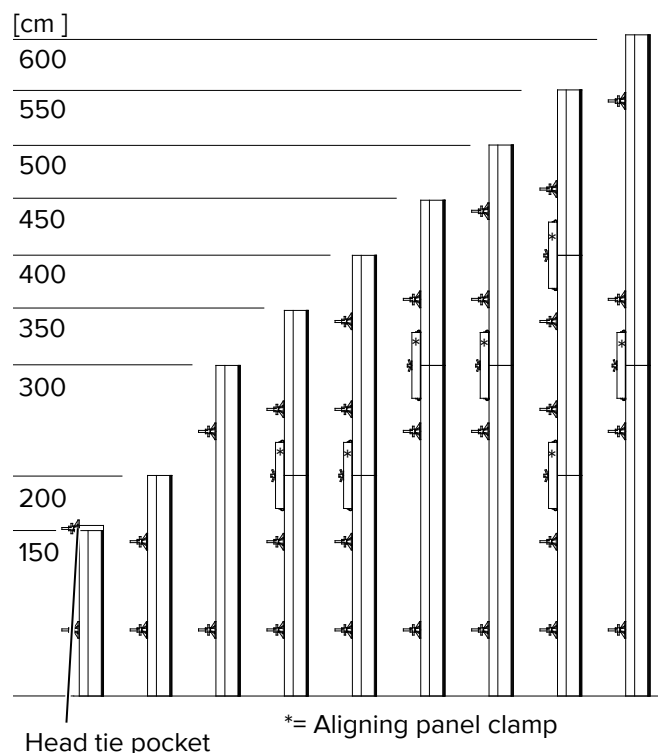

11 Bracing

11.1 With the RONDA aligning props

The RONDA circular formwork is braced and aligned by using RONDA aligning props up to a height of 4.5 m which can either be connected to the trapezoid profiles or at the element joint (without timber infill) by using 2 panel clamps.

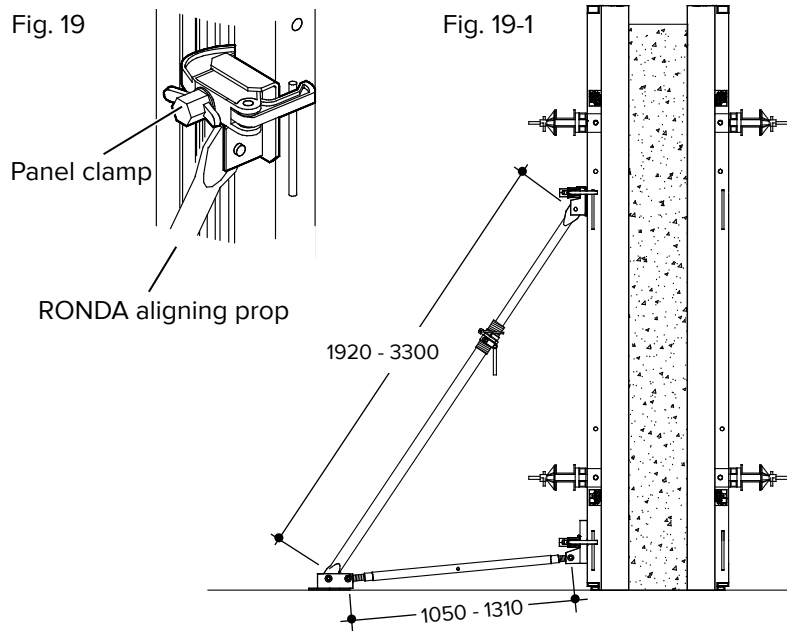

WARNING

Warning!

The user has to provide a sufficient anchorage for the aligning props.

11.2 With tubular steel props

Formwork heights between 4.0 m and 6.0 m are braced with steel props which are equipped with an additional counter nut and connected to the RONDA formwork by using the RONDA prop adaptor and the panel clamp. The strut base joint is used to transfer loads into the capable ground. Additionally, 4 bolts M12 x 30 are required for each head- and base plate of the steel props.

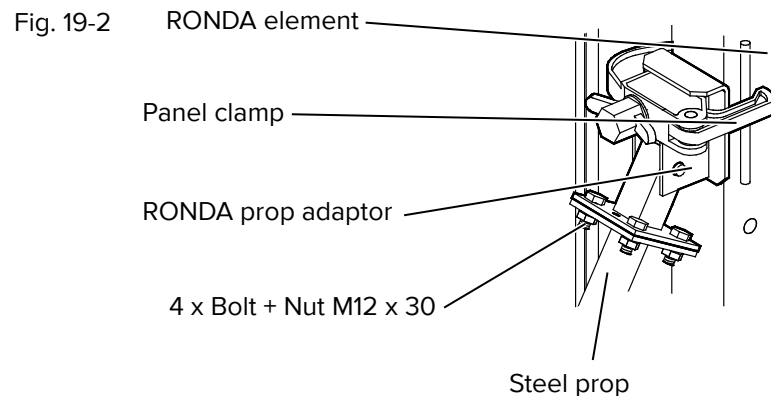
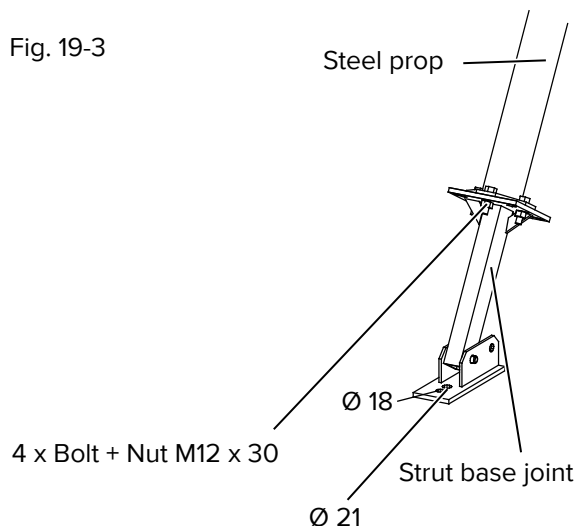

Fig. 19-3



WARNING

Warning!

The permitted tension load of the steel props (with counter nut) is 15 kN. Compression loads according to the EUROPLUS® load table.

11.3 With BKS props

To brace and align RONDA elements higher than 6 m, additional BKS aligning struts are required. The necessary connecting part „RONDA BKS“ is mounted with a panel clamp. BKS aligning struts can be combined up to a maximum length of 12.0 m. For further information on BKS aligning struts see the MANTO® user guide or contact HÜNNEBECK.

Fig. 19-2 RONDA BKS connector

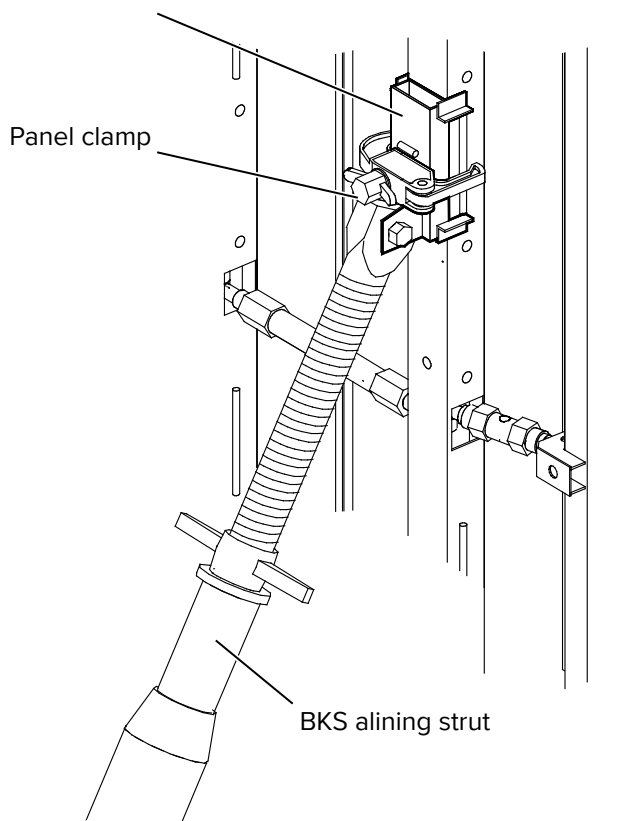

WARNING

Warning!

Formwork that reaches heights higher than 6.0 m must be erected separately.

12 Wall connection

When connecting RONDA elements to an existing wall, the elements must overlap at least 25 cm.

Fig. 21

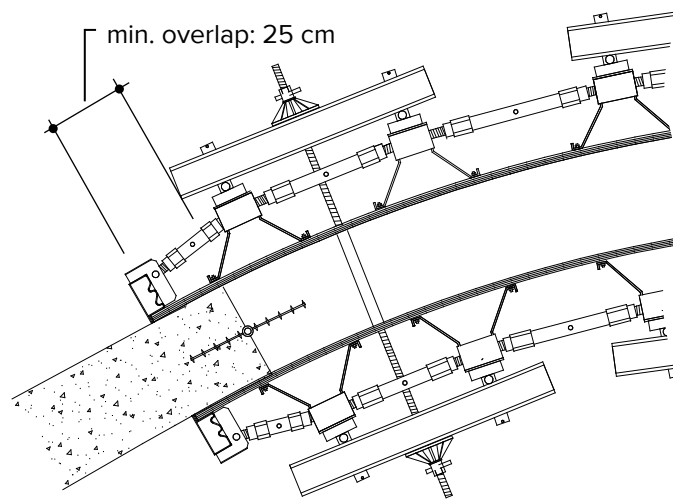

13 Stopend

Loads resulting from the stopend design will be transferred via cross walers (e. g. multi purpose waler) into the elements. The waler is connected by 2 waler spanners and 2 tension nuts and has to be installed at each level of the turnbuckles. When using RONDA elements with tie walers, additional tie rods must be arranged at the front end of the formwork. These additional tie rods are installed by using the MANTO® edge tie fasteners MR in the same height as the spindles at the edge profiles outside the formwork.

Fig. 22

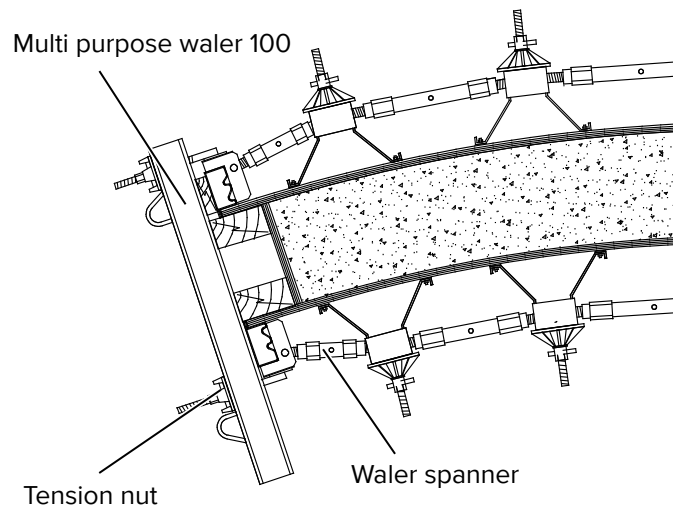
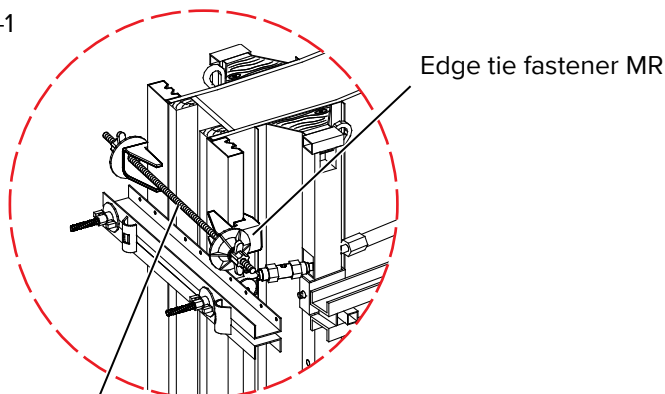
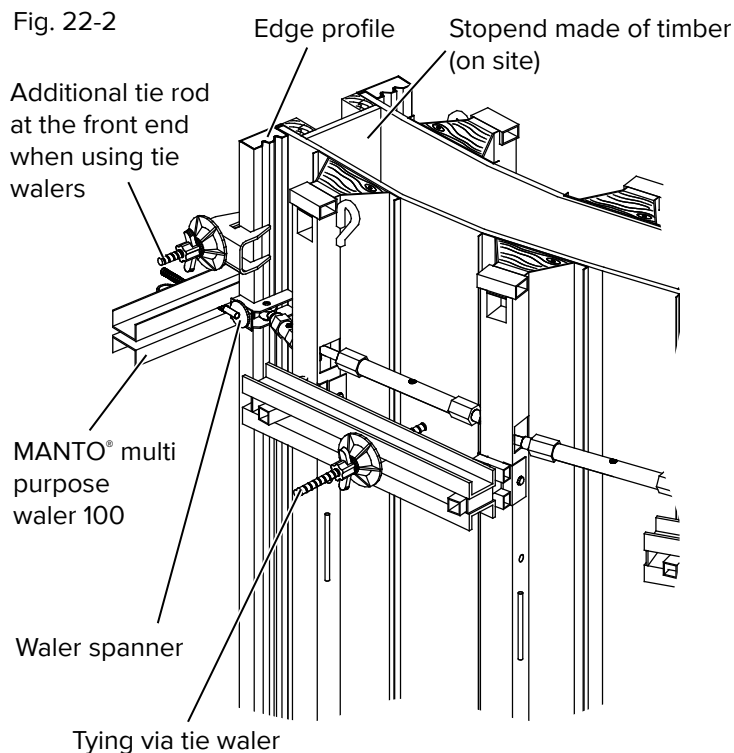

Fig. 22-1



Additional tie rod at the front end when using tie walers

Fig. 22-2



14 Walkway brackets

The walkway brackets are attached to the RONDA elements. The connection of the walkway bracket is achieved by using the upper connection hole of the trapezoid profile and by fastening the suspension claw of the bracket with the captivated bolt and spring pin.



WARNING

Warning!

The max. distance for the arrangement of the walkway brackets is 2.0 m. The planking has to be secured against lifting.

NOTE

Note

The permitted load of the walkway platform is 1.50 kN/m².

Fig. 23

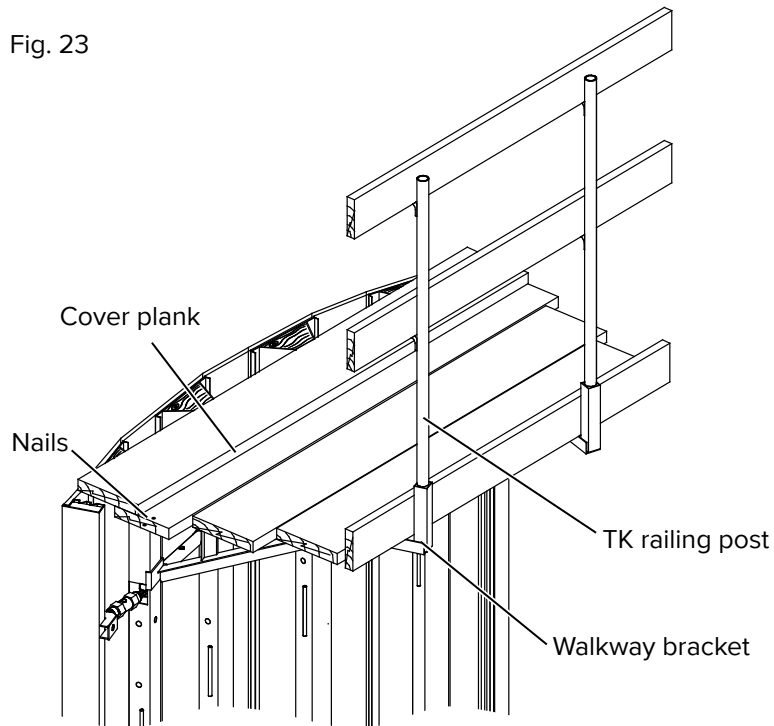

After inserting the TK railing post, the walkway brackets must immediately be covered with planks and provided with the three-part railing. Planks and railing components have to be supplied on site and must comply with local regulations and safety rules. The gap between the RONDA element and the platform planking has to be covered by using a plank, which protects against impurities by concrete as far as possible.

Fig. 23

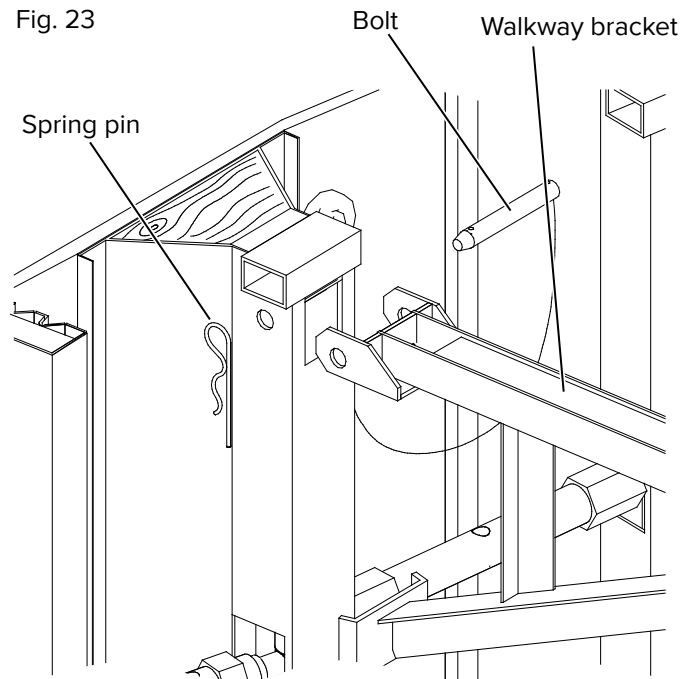

15 Transportation of elements by crane

Each RONDA element is equipped with two crane eyes which are welded to the steel profiles. The crane eyes allow to attach of crane ropes for lifting and shifting of individual elements or combined units. The maximum shifting-weight of a combined unit is limited to 1,000 kgs (= 10.0 kN, approx. 20 m²). Make sure that the length of the crane ropes allows a minimum rope-angle of > 60°.

 **WARNING**

Warning!

Before lifting more than one RONDA element, combine the elements with a band.

 **WARNING**

Warning!

The crane ropes must be attached to both suspension eyes of the element. These crane ropes are attached to the crane hook. It is not permissible to attach the crane hook or crane tackle directly to the suspension eyes of the formwork!

 **VISUAL CHECK**

The RONDA elements must be transported as straight pieces (without curve), face sheet to face sheet, as shown in the picture.

Fig. 24

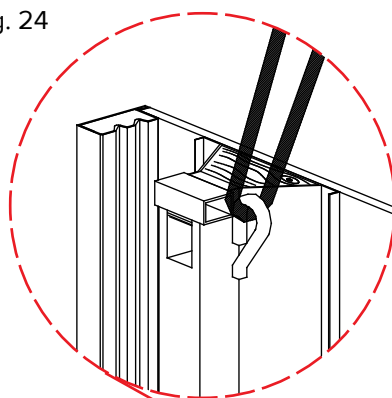
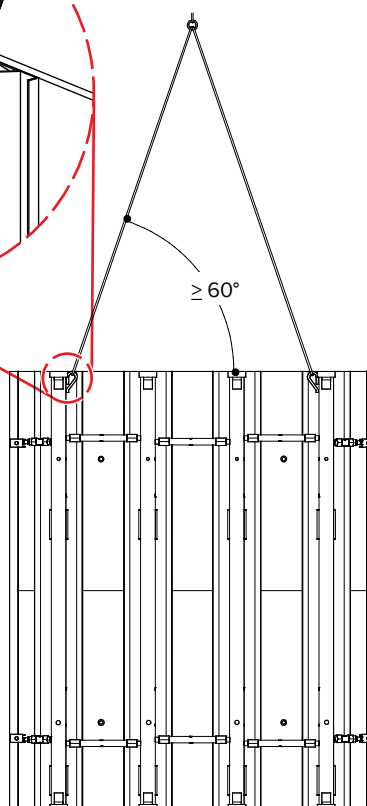

Fig. 25



Transportation of elements by crane

To transport the RONDA elements as a bundle , always attach the crane ropes crossways to the direction of the trapezoid steelprofiles. Do not move more than four RONDA elements per bundle.

Fig. 26

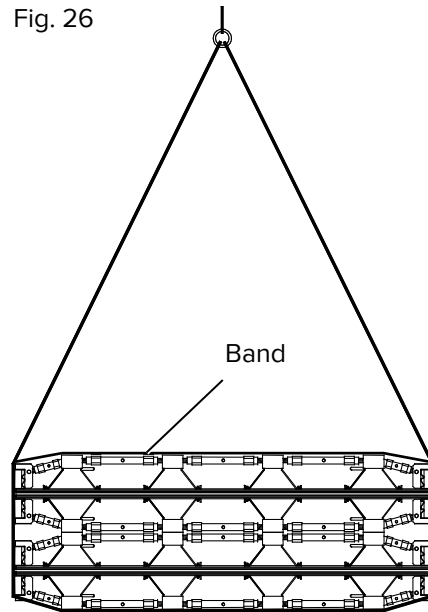

16 Chronology

Changes compared to issue 2012-03		
Changes	Page	Date
Layout updated	div	2018-12

**Hünnebeck
Deutschland GmbH**
Rehhecke 80
D-40885 Ratingen
+49 2102 9371
info_de@huennebeck.com
www.huennebeck.com

The copyright in these instructions for assembly and use belongs to BrandSafway. All the trademarks named in these instructions for assembly and use are the property of BrandSafway, unless marked as third-party rights or identifiable as such in another way. Hünnebeck, SGB and Aluma Systems are trademarks of BrandSafway. Furthermore, all rights are reserved, particularly with regard to patent grant or utility model registration. The unauthorized use of these instructions for assembly and use, of the trademarks contained therein and other intellectual property rights is expressly prohibited and represents an infringement of copyright, trademark rights and other industrial property rights.

The illustrations in this brochure depict actual site conditions which may not always conform with applicable safety rules and regulations.

Last updated: December 2018
Keep for later use!