

TOPMAX

Steel Frame Table Form

User guide



Contents

1	Product features	3
1.1	Intended use	3
2	General information	4
2.1	Safety instructions	4
2.2	Method Statement guidelines	4
2.3	Equipment information	5
2.4	Document information	6
2.5	Other information.....	7
3	Overview	8
4	Components	9
4.1	Core components	9
4.2	Ancillary components	9
4.3	Adapters, bearings and props	11
4.4	Tripods	14
4.5	Stabilizers.....	15
4.6	Working platforms.....	16
4.7	Edge protection.....	16
4.8	Table transport.....	20
4.9	Lifting.....	22
4.10	Tools	23
4.11	Storage	24
5	Applications	26
5.1	TOPMAX Floor Tables.....	26
5.2	Props and bearings	29
5.3	Extension Frames	45
5.4	Extension panels.....	51
5.5	Working platforms.....	63
5.6	Edge protection.....	66
5.7	Stabilizing aids.....	79
5.8	Infills	87
5.9	TOPEC Bolts	107
5.10	Stop ends	108
6	Table Transport	111
6.1	Multi Mover.....	111
6.2	Positioning Unit	135
6.3	TOPMAX Electric Table Jack Lift.....	142
7	Lifting	145
7.1	TOPMAX Crane Suspension.....	145
7.2	TOPMAX Lifting Fork	148
7.3	TOPMAX Table Lifting System.....	150
8	Notes on structural analysis	152
9	Chronology	153

1 Product features

The TOPMAX floor table system from Hünnebeck is a fast and economical floor table system for large-area slabs with a thickness of up to 500 mm and a clear room height of up to 7.62 m. Slabs up to 500 mm thick meet the requirements of line 7 of DIN 18202. Thicker slabs can be achieved by statical calculations.

The TOPMAX floor table system consists of a robust and hot-dip galvanized steel frame with a concrete-repelling powder coating. The high-performance full plastic form sheet is protected by the steel frame of the panel providing an even concrete face of the highest quality and reducing the refinishing work to a minimum.

The optimized combination of steel and plastic turns TOPMAX into a long-lasting and high-quality floor table system.

The TOPMAX floor tables are supported by the standard props of Hünnebeck.

TOPMAX floor tables are available in the dimensions 2.40 x 5.40 m and 1.80 x 5.40 m achieving formed areas of 12.96 m² and 9.72 m².

Two floor tables with an area of up to 25.92 m² can be lifted by crane in just one pick.

The props are connected to the tables with the TOPMAX Folding Head. The integrated folding mechanism allows swivelling the mounted props over parapets or other obstacles easily and quickly without removing the props.

TOPMAX also includes a system solution for the forming of slab edges almost completely without nailing.

TOPMAX floor tables are compatible with the Hünnebeck wall formwork RASTO/TAKKO and with the TOPEC slab formwork system. That extends the range of additional system solutions for infill areas.

TOPMAX is also compatible with the PROTECTO, Uni Mesh Panels and EXTRAGUARD edge protection systems and provides that way a maximum of safety.

1.1 Intended use

The typical assembly shown in this user guide is intended to form large area slabs and to transfer the resulting horizontal and vertical loads into the ground.

A system based slab edge formwork, working platforms and compatibility to RASTO/TAKKO, TOPEC, PROTECTO, Uni Mesh Panels and EXTRAGUARD expand the functionality and range of use.

The permitted loads have to be observed.

Hünnebeck products are intended exclusively for commercial use by technically suitable users.

This user guide is intended for commercial users with appropriate technical training. The contents and processes described are in accordance with the legal and occupational safety regulations. Hünnebeck assumes no liability for deviations from the contents and processes described or for use outside this area of application.

2 General information

This user guide for assembly and use contains important information regarding the assembly and use of the TOPMAX system, as well as safety advice. These instructions are created to support effective working processes on site when using the TOPMAX system, therefore carefully read this user guide before assembly and use of the system, always keep it at hand and archive it for future reference.

2.1 Safety instructions

It is the responsibility of the site Management / Supervisors to ensure that all operatives involved in the assembly of the TOPMAX system have been made aware of this document and that they understand the drawings and the function of the various components. The Contractor is also responsible for drawing up a comprehensive risk assessment and a set of installation instructions. The latter is not usually identical to the assembling instructions.

Risk assessment

The Contractor is responsible for the compilation, documentation, implementation and revision of a risk assessment for each construction site. His / her employees are obliged to implement the resulting measures in accordance with all legal requirements.

Assembly instructions

The assembly instructions are an integral component of the TOPMAX construction and are a part of the installation instructions. They comprise safety guidelines, details of standard configurations and intended use as well as the system's description. The functional instructions (standard configuration) contained in the assembly instructions are to be complied with as stated. Enhancements, derivations or changes represent a risk and therefore require separate verification with the help of a risk assessment or a set of instructions which comply with the relevant laws, standards and safety regulations. The same also applies in those cases where components are provided by the Contractor.

Availability of the assembly instructions

The Contractor has to ensure that the assembly instructions provided by the manufacturer or supplier are available at the place of use. Site personnel are to be informed of this before assembly and use takes place and that they are available at all times.

Detailed assembly

The method of erection / dismantling detailed is intended to be used as a general guide to inform the user about the product's details to enable safe use. It must not be used as a substitute for a contractor's specific risk assessment and method statement, and all relevant health and safety regulations must be adhered to. Due to the variety of possible configurations of temporary work systems, the method of erection or parts of it may differ from that shown. Additionally, alternative methods of erection may be preferred or developed in which case it is imperative that all relevant health and safety legislation is adhered to.

2.2 Method Statement guidelines

Hünnebeck can provide further guidance and on-site assistance on any issues contained in this document that are not clear. Further information can be found in the product's data sheets. IF IN DOUBT ASK.

Design Risk Assessment

Where relevant site-specific scheme designs are produced, they will generally be to a recognised standard arrangement otherwise calculations will be done to verify the design.

The Design Risk Assessment is an integral part of Hünnebeck's design process.

The designer will assess the hazards and risks associated with erection, use and dismantling of the temporary works at an early stage of the design process.

Hünnebeck will communicate where risks to health and safety remain by including a "Residual Risk Note" on the drawing. This note will be clearly visible and marked by the familiar black exclamation mark on a yellow triangle. The statement will be brief but clear to enable appropriate action by a competent contractor.

Hünnebeck draws attention to the following Health and Safety legislation:

The Construction (Health, Safety and Welfare) Regulations 1996 (CHSW Regs);
 Construction (Design and Management) Regulations 2015 (CDM Regs);
 Lifting Operations and Lifting Equipment Regulations 1998 (LOLER);
 Work at Height Regulations 2005 (WaH Regs);
 Manual Handling Operations Regulations 1992 (MHO Regs).
 The Personal Protective Equipment at Work Regulations 1992 (PPE Regs)

Work at Height Regulations - Hierarchy of Controls Avoiding Work at Height

Work at height can be reduced / eliminated by considering the method of assembly and use:

- Edge protection that is designed to be re-used reduces the amount of time and effort required for dismantling and re-erecting;
- Installing completed edge protection when the formwork is on the ground will remove work at height associated with the construction later on.

**Preventing Falls - The use of guardrails and other collective measures
 The use of PPE / Safety Harnesses.**

Suitable PPE MUST be used at all times during assembly and dismantling of this equipment. Lanyards MUST always be secured to a suitable part of the structure, or certified anchor point of other equipment. Always consider the attachment level and deployment (extension) of the lanyard when under load.

2.3 Equipment information

Material deliveries are to be checked on arrival at the construction site / place of destination, as well as before each use, to ensure it's in serviceable condition and functions correctly. Changes to the material are not permitted.

On-site preparations

The Contractor must ensure the appropriate environment and conditions for storage and the particular application of the system(s) supplied.

Storage and transportation

The special requirements of the TOPMAX system either as individual components and/ or as pre-assembled parts regarding storage and transportation procedures must be complied with. This applies not only to and from the site but also to the movement of individual components and / or pre-assembled parts on the construction site / place of use.

Lifting

When applicable, the lifting requirements of the individual components and / or pre-assembled parts must be followed.

Genuine components

The information provided assumes that any product combinations will be between genuine Hünnebeck products or products supplied by Hünnebeck unless otherwise stated.

Combining components from different manufacturers carries certain risks. They are to be individually verified and a separate set of instructions for the installation of the equipment may be required.

Any unauthorised use in relation to third party products could give rise to a risk of collapse, damage, injury or death.

Spare parts and repairs

Only original components may be used as spare parts. Repairs are to be carried out by the manufacturer or by authorised facilities only.







2.4 Document information

Representations

The representations shown in the assembly instructions are in part, situations of assembly and not always complete in terms of safety considerations. The safety installations which have possibly not been included in these representations must be available and must be in accordance with the latest regulations. Overviews and diagrams are for illustrative purposes only and whilst we endeavour to ensure accuracy, we are not responsible for omissions or errors.

Safety symbols

Individual safety symbols are to be complied with. Examples:

 DANGER	Danger! DANGER indicates a hazardous situation that, if not avoided, will cause death or serious injury.
 WARNING	Warning! WARNING indicates a hazardous situation that, if not avoided, can cause death or serious injury.
 CAUTION	Caution! CAUTION indicates a hazardous situation that, if not avoided, can cause minor or moderate injury.
NOTICE	Notice! NOTICE indicates a hazardous situation that, if not avoided, can cause property damage.
	This note indicates that an additional check, visual or otherwise, is required.
	This note shares practical experience with the user, e.g. how to more easily or quickly perform a task.
	This note draws the user's attention to particularly important information, e.g. that a pre-requisite must be fulfilled.
	This symbol indicates that additional information from other documents is required. These documents could be user guides or operating instructions for other products.

User guide compliance

Hünnebeck will not be liable for any damage to property, personal injury or any losses caused by failure to follow the instructions contained in this guide. It remains the

responsibility of the user to comply with the applicable legislation.

2.5 Other information

This guide provides an overview of the TOPMAX system's instructions for assembly and use. More specific component data sheets are available upon request for some product lines. Hünnebeck reviews and updates its product guidance from time to time. Due to continuous development, it is important that only current documents are used.

Hünnebeck reserves the right to alter or amend, without notice, the design and/or specifications of products in the interests of improvement or when required to comply with new regulations, other safety guidances or industry advancements.

Hünnebeck also issues safety notes on its products or packaging where required. These notices may affect the manner in which products are used and should therefore be adhered to. The most recent published notice should prevail.

All information in this guide is correct at the time of going to press and / or other publication media.

For the latest version of this and other user guides please visit:

<http://huennebeck.com/downloads>

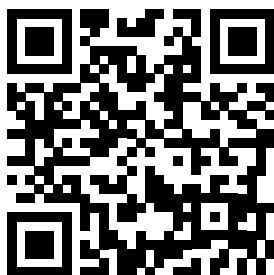

SGB, Hünnebeck, ALUMA and BRAND are trading names of BRANDSAFWAY.

3 Overview

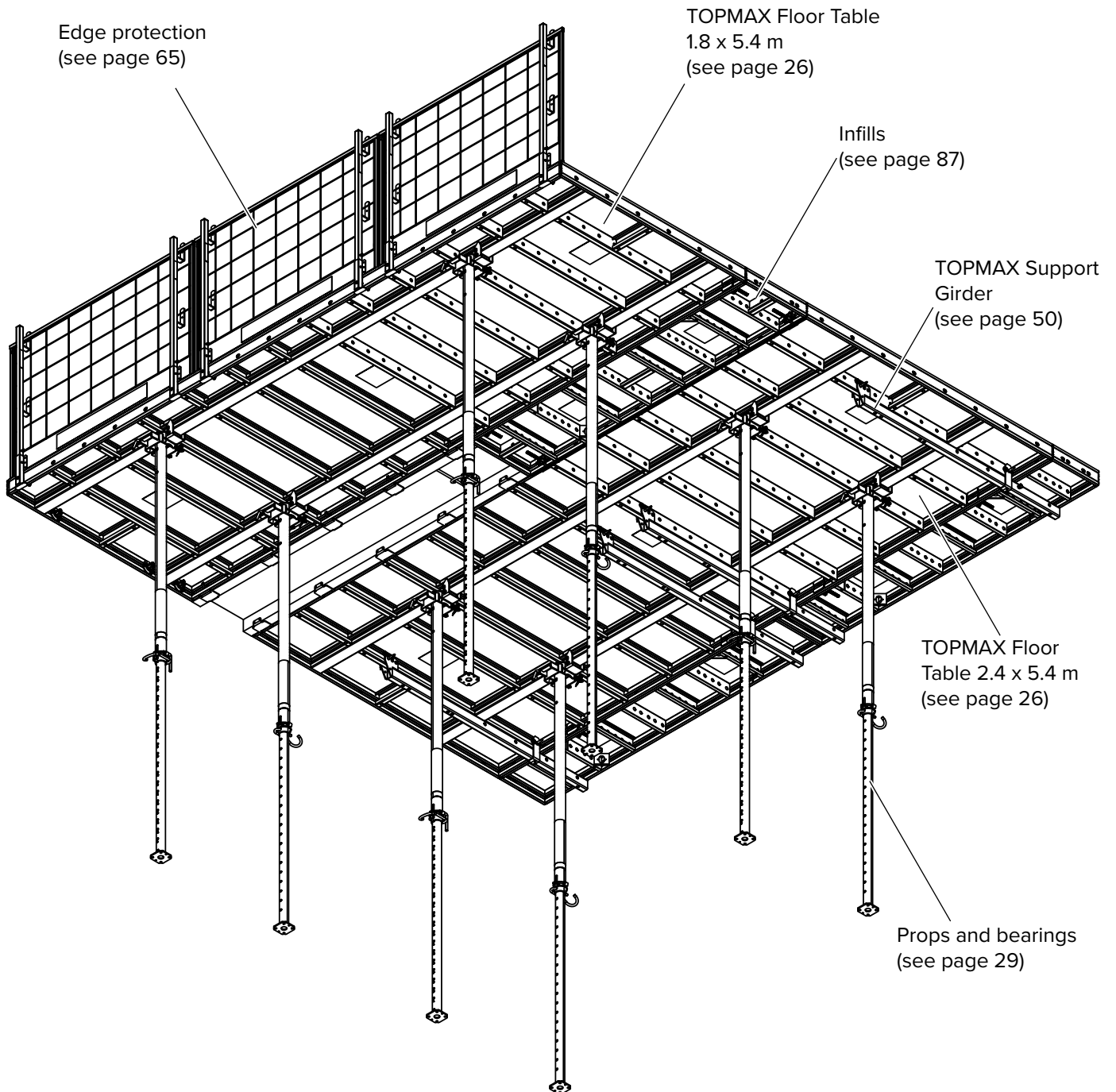

4 Components

4.1 Core components

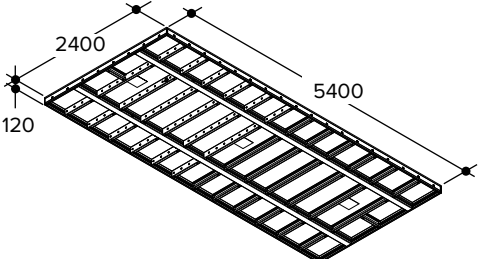
	Component	Part code	Weight [kg]
	TOPMAX Floor Table 2.4 x 5.4 m Floor table with a forming area of 12.96 m ² . See page 26.	602586	495.00

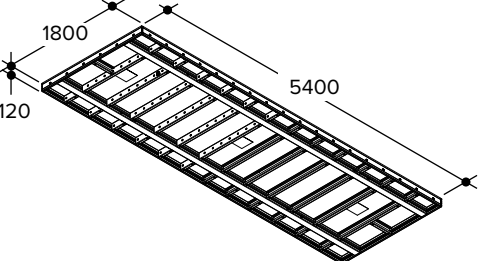
	TOPMAX Floor Table 1.8 x 5.4 m Floor table with a forming area of 9.72 m ² . See page 26.	603185	421.88
------------------------------------------------------------------------------------	-------------------------------------------------------------------------------------------------------------------	---------------	---------------

4.2 Ancillary components

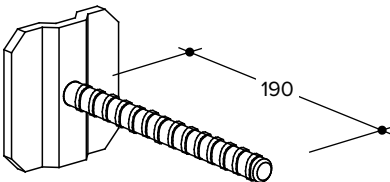
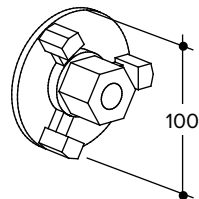
	Component	Part code	Weight [kg]
	Centering Tension Bolt Used in combination with the Centering Nut 100 as a tensile connection between the TOPMAX Floor Tables and when combining TOPMAX and RASTO panels. It is positioned through the hole pattern in the edge profile of the panels to achieve a flush panel joint. Also used to connect Wall Struts and Stopped Angles Safe Working Load: 40.00 kN. See page 28.	479264	0.91
	Centering Nut 100 Used to secure tensile connections. See page 28.	469566	0.80

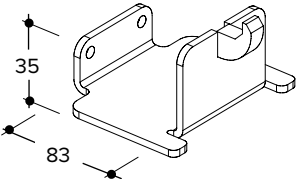
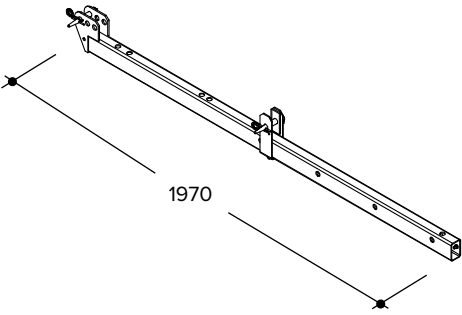
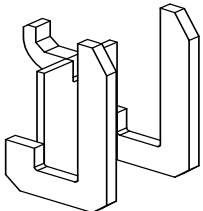
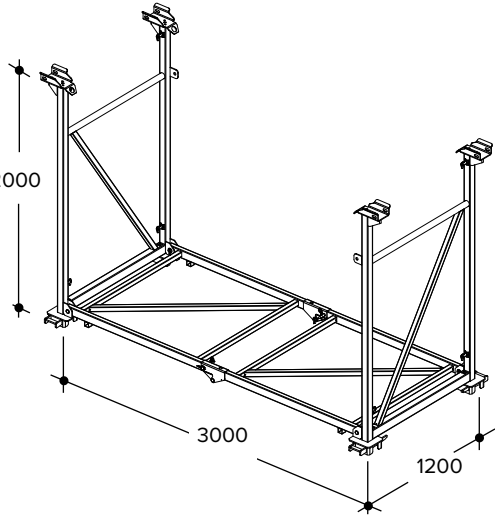
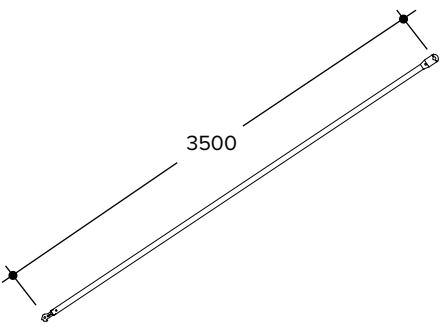
	Component	Part code	Weight [kg]
	<p>TOPMAX Timber Holder</p> <p>Connects to the holes on the edge profiles and supports 80 x 100 mm timber for plywood infills.</p> <p>Safe Working Load: 1.90 kN.</p> <p>See page 87.</p>	603235	0.72
	<p>TOPMAX Support Girder</p> <p>Used to support the RASTO and TAKKO panels when used in combination with TOPMAX. Can also be used to create infills or extend a deck area.</p> <p>See page 50.</p>	603390	17.83
	<p>TOPMAX TOPEC Adapter</p> <p>This adapter is used to support TOPEC panels in infill areas between TOPMAX Floor Tables.</p> <p>See page 103.</p>	604515	0.84
	<p>TOPMAX Extension Frame</p> <p>The TOPMAX Extension Frame is used at building sites with greater slab heights of up to 7.62 m (clear floor height). The frame enables the re-use of props for typical lower areas in the non-typical higher areas without exchanging the entire falsework system.</p> <p>Used in conjunction with the Diagonal 203.</p> <p>See page 44.</p>	603479	165.64
	<p>Diagonal 203</p> <p>This diagonal is used to stiffen the TOPMAX Extension Frame.</p> <p>Each TOPMAX Extension Frame requires 2no. Diagonal 203 and 4no. TOPMAX Locking Pins.</p> <p>See page 44.</p>	110167	7.90

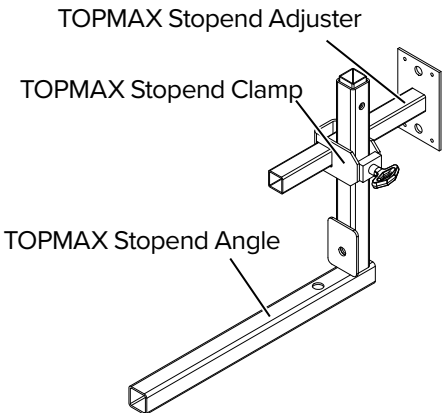
	Component	Part code	Weight [kg]
 <p>TOPMAX Stopend Adjuster</p> <p>TOPMAX Stopend Clamp</p> <p>TOPMAX Stopend Angle</p>	TOPMAX Stopend Adjuster	603379	2.30
	TOPMAX Stopend Clamp	603432	1.38
	TOPMAX Stopend Angle	603375	6.82
	<p>This assembly is used to build the TOPMAX stop end form.</p> <p>Each assembly requires 1no. Centering Tension Bolt and 1no. Centering Nut 100 when used with TOPMAX Floor Tables or 1no. RASTO MP-Bolt and 2no. Centering Nut 100 when used with the TOPMAX Working Platform.</p> <p>See page 108.</p>		

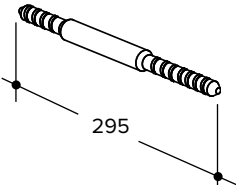
	RASTO MP-Bolt	485435	0.60
	<p>The TOPMAX Stopend Angle is mounted to the TOPMAX Working Platform, using 1no. RASTO MP-Bolt and 2no. Centering Nuts 100.</p> <p>See page 108.</p>		

4.3 Adapters, bearings and props

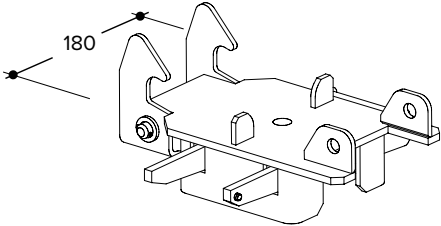
	Component	Part code	Weight [kg]
	TOPMAX Folding Head	602596	7.65
	<p>This item is used for connecting EUROPLUS^{new} props to the TOPMAX Floor Table.</p> <p>Its in-built mechanism allows the props to be swung along the longitudinal side of the table. This can be necessary if the building has parapets at its edge.</p> <p>Each folding head requires 1no. additional TOPMAX Locking Pin to be ordered separately.</p> <p>See page 36.</p>		

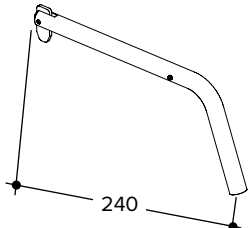
	TOPMAX Locking Pin	603067	0.48
	<p>The self-locking pin secures the TOPMAX Folding Head to the TOPMAX Floor Table at the predetermined standard positions.</p>		

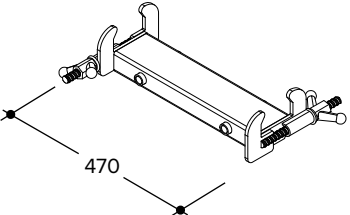
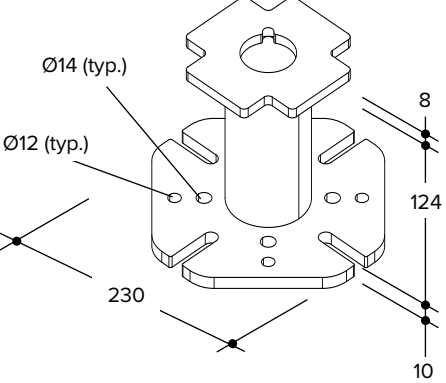
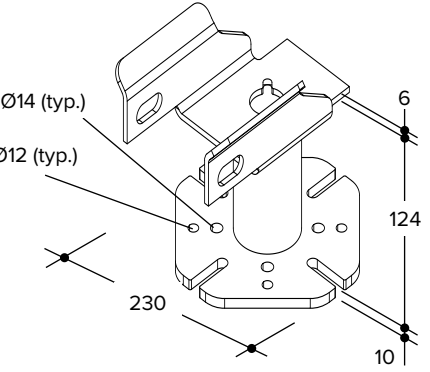
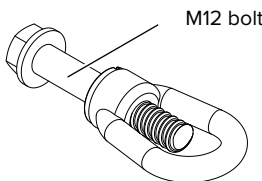
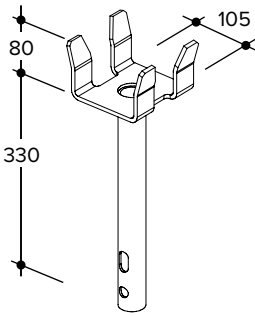
	Component	Part code	Weight [kg]
	<p>TOPMAX Head Adapter</p> <p>This adapter can be attached along the main beam of the TOPMAX Floor Table if the props must be moved out of the standard predetermined position or if the TOPMAX Floor Table is supported with additional props for structural reasons.</p> <p>An additional TOPMAX Folding Head and 1no. TOPMAX Locking Pin need to be ordered additionally.</p> <p>See page 38.</p>	603442	7.57
	<p>TOPMAX GASS Multi Adapter</p> <p>Used to connect props, typically GASS Legs, to the TOPMAX Folding Heads on the TOPMAX Floor Tables.</p> <p>It requires 4no. Ring Bolt Clamp for GASS Leg to GASS Leg, 1no. TOPMAX Folding Head and 1no. TOPMAX Locking Pin per adapter.</p> <p>See page 39.</p>	606993	4.62
	<p>TOPMAX GASS Tower Adapter</p> <p>Used to connect props, typically GASS Legs, to the main profile of the TOPMAX Floor Tables.</p> <p>It requires 4no. Ring Bolt Clamp for GASS Leg to GASS Leg per adapter and 1no. TOPMAX Locking Pin.</p> <p>See page 42.</p>	606994	5.89
	<p>Ring Bolt Clamp for GASS Leg to GASS Leg</p> <p>Used to secure the TOPMAX GASS Multi Adapter and the TOPMAX GASS Tower Adapter to the GASS Legs.</p> <p>Each bearing requires 4no. Ring Bolt Clamp for GASS Leg to GASS Leg.</p>	718901	0.23
	<p>TOPMAX Prop Fixing Part</p> <p>Provides an additional support point for the TOPMAX Floor Tables and RASTO Panels.</p> <p>An additional suitable TOPEC bolt is required to secure it to the EUROPLUS^{new} Props.</p> <p>See page 99.</p>	603141	2.02

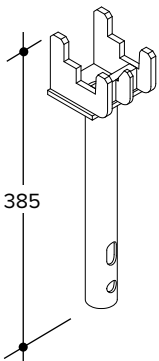
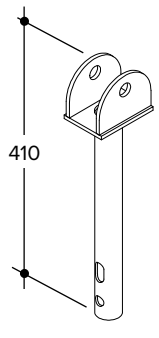
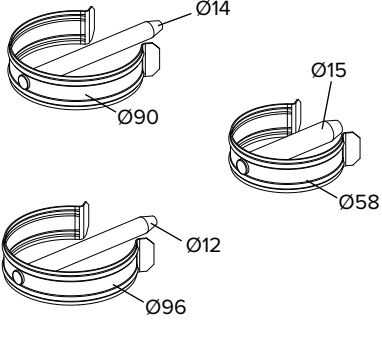
	Component	Part code	Weight [kg]
	<p>TOPMAX Connection Bearing</p> <p>This part is used to support TOPEC formwork that can be connected to TOPMAX Floor Tables.</p> <p>An additional suitable TOPEC bolt is required to secure it to the EUROPLUSnew Props.</p> <p>See page 105.</p>	<p>603465</p>	<p>2.04</p>
	<p>TOPMAX Lockable Head</p> <p>Used together with the TOPMAX Support Girder when additional support to the beam is required.</p> <p>An extra Waler Bolt D20 (code:420000) and a Spring Pin 4 (code:173776) have to be ordered separately. An additional suitable TOPEC bolt is required to secure it to the EUROPLUSnew Props.</p> <p>See page 52.</p>	<p>603404</p>	<p>1.55</p>
	<p>TOPEC Bolt D14</p> <p>TOPEC Bolt</p> <p>TOPEC Bolt Alu 500 DC</p> <p>Self-locking bolt to fix the TOPMAX Prop Fixing Part, the TOPMAX Lockable Head as well as the TOPMAX Connection Bearing.</p> <p>See pages 52, 99 and 107.</p>	<p>604365</p> <p>470804</p> <p>569384</p>	<p>0.18</p> <p>0.15</p> <p>0.15</p>

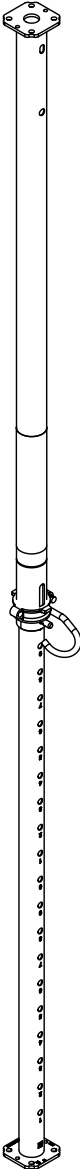
	Component	Part code	Weight [kg]	
	EUROPLUS^{new} 20-250* (1470 mm - 2500 mm)	601390	13.15	
	EUROPLUS^{new} 20-300* (1720 mm - 3000 mm)	601400	16.82	
	EUROPLUS^{new} 20-350* (1980 mm - 3500 mm)	601410	20.52	
	EUROPLUS^{new} 20-400* (2240 mm - 4000 mm)	601415	23.79	
	EUROPLUS^{new} 20-550* (3030 mm - 5500 mm)	601425	36.07	
	EUROPLUS^{new} 30-150** (1040 mm - 1500 mm)	601460	10.68	
	EUROPLUS^{new} 30-250** (1470 mm - 2500 mm)	601430	16.19	
	EUROPLUS^{new} 30-300** (1720 mm - 3000 mm)	601440	19.17	
	EUROPLUS^{new} 30-350** (1980 mm - 3500 mm)	601445	24.24	
	EUROPLUS^{new} 30-400** (2240 mm - 4000 mm)	601450	28.75	
	<p>All steel props are hot-dip galvanized and have a quick-lowering mechanism and an anti-crush guard as well. Additionally the props have a protection to prevent the sliding-out of the inner tube.</p> <p>*Safe Working Load (as single prop): 20.00 kN (class D)</p> <p>**Safe Working Load (as single prop): 30.00 kN (class D)</p> <p>See page 29.</p>			

4.4 Tripods

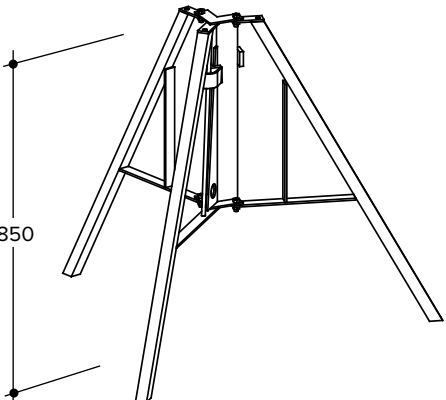
	Component	Part code	Weight [kg]
	Uni Tripod	587377	11.83
	<p>The Uni Tripod is an assembly aid used during erection for stability purposes for free-standing single slab tables higher than 3.60 m.</p> <p>Not to be used to transfer lateral loads.</p> <p>Min. Ø57 mm, max. Ø90 mm.</p> <p>See page 35.</p>		

4.5 Stabilizers

Component	Part code	Weight [kg]
Wall Strut, Size 3 (270–340 cm)	506430	22.00
Wall Strut, Size 4 (320–390 cm)	506463	24.00
Wall Strut, Size 5 (420–490 cm)	506485	27.00
Wall Strut, Size 6 (530–590 cm)	506555	40.00

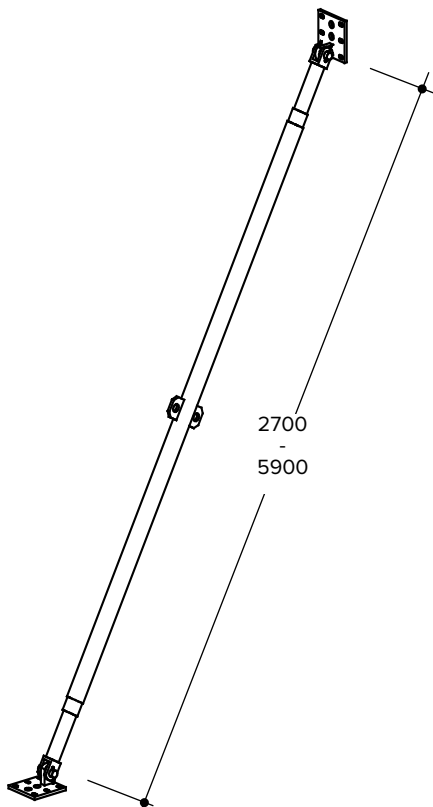

The push-pull proofed wall struts are typically used to transfer tensile and compressive lateral loads and to align TOPMAX Floor Tables.

Also used to stabilize the tables during the first installation.

The struts can be attached in both directions using a Centering Tension Bolt and a Centering Nut 100.

The Customer is responsible for the anchors (dowels and screws) used to secure the strut to the existing structure
See page 79.

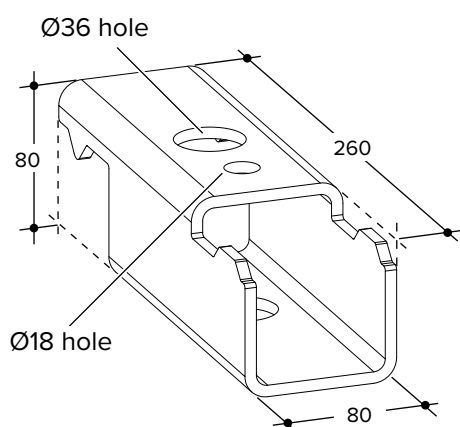

Panel Anchor Bracket	605999	2.27
-----------------------------	---------------	-------------

The Panel Anchor Bracket is used to provide horizontal restraint to TOPMAX tables.

The bracket has 2no. Ø18 holes on opposite sides (one hole not visible), for locating the anchor. The larger Ø36 holes are placed to allow the spanner extension to pass through.

See page 81.

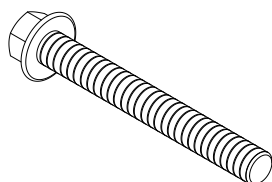

Anchor Bolt MM+SSK 16 x 130	443500	0.21
------------------------------------	---------------	-------------

Used to temporarily secure the Panel Anchor Bracket to the existing structure. Only one bolt is required per bracket.

See page 81.

4.6 Working platforms

Component	Part code	Weight [kg]
TOPMAX Working Platform 1.8	603343	78.23
TOPMAX Working Platform 2.4	603342	91.04

Pre-assembled safe working platform with foldable edge protection.
 Can be used to provide additional access area to TOPMAX Floor Tables.
 Safe Working Load: 1.50 kN/m².
 See page 63.

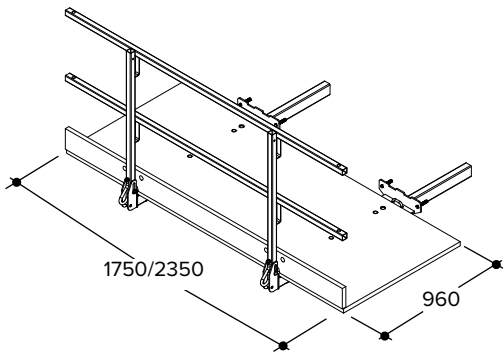

KG Rail Extension	498218	3.60
--------------------------	---------------	-------------

The KG Rail Extension is used at adjustments to close gaps in the railing between the platforms.
 With each rail extension one Waler Bolt D 20 (code:420000) and one Spring Pin 4 (code:173776) have to be ordered.
 See page 106.

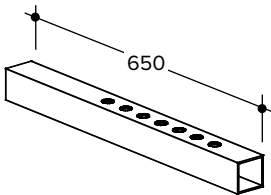

4.7 Edge protection

Component	Part code	Weight [kg]
TOPMAX Post Fastener	603123	1.02

Used to attach a PROTECTO Post to a TOPMAX Floor Table and secured using a Centering Nut 100.
 Maximum allowable post spacing is 2.40 m with mesh panels and 2.00 m with railing boards class C24 30 x 150 mm.
 See page 67.

Not available in the U.K.

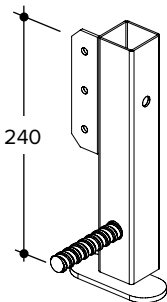

PROTECTO Railing Post	601225	3.65
------------------------------	---------------	-------------

The PROTECTO Railing Post together with the Uni Mesh Panels or with the PROTECTO Mesh Panels provides an edge protection at the leading edges of TOPMAX Floor Tables.
 See page 67.

Not available in the U.K.

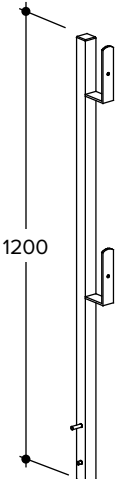

Component	Part code	Weight [kg]
-----------	-----------	-------------

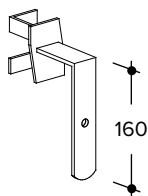

PROTECTO Toe Board Retainer

601227

0.69

This additional part for the PROTECTO Railing Post holds the toe board of the board railing. The PROTECTO Toe Board Retainer can be easily attached to an already mounted PROTECTO Railing Post. See page 67.

Not available in the U.K.

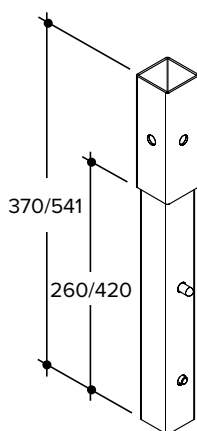

PROTECTO Post Extension 26

602111

0.95

PROTECTO Post Extension 42

602580

1.20

It provides an extension to the PROTECTO Railing Post by 260 or 420 mm.

See page 69.

Not available in the U.K.

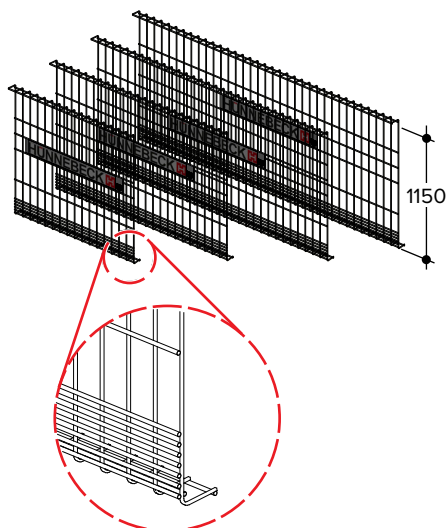

PROTECTO Mesh Panel 263

601231

22.00

(1150 x 2630 mm)

PROTECTO Mesh Panel 240

604730

20.00

(1150 x 2400 mm)

PROTECTO Mesh Panel 180

604731

15.18

(1150 x 1800 mm)

PROTECTO Mesh Panel 130

604733

10.55

(1150 x 1300 mm)

The hot-dip galvanized PROTECTO Mesh Panel is a complete edge protection, which is quickly and easily mounted to the PROTECTO Railing Posts providing excellent edge protection flexibility.

See page 67.

Not available in the U.K.

No longer in production.

Component	Part code	Weight [kg]
Uni Mesh Panel 270 RAL *	607929	17.09
Uni Mesh Panel 270 (1150 x 2700 mm)	607945	18.59
Uni Mesh Panel 240 RAL *	607928	15.52
Uni Mesh Panel 240 (1150 x 2400 mm)	607940	16.88
Uni Mesh Panel 180 RAL *	607927	12.22
Uni Mesh Panel 180 (1150 x 1800 mm)	607985	13.28
Uni Mesh Panel 120 RAL *	607926	8.92
Uni Mesh Panel 120 (1150 x 1200 mm)	607955	9.69

Used in conjunction with the PROTECTO Posts to provided edge protection at the leading edges of the TOPMAX Floor Tables.
See page 74.

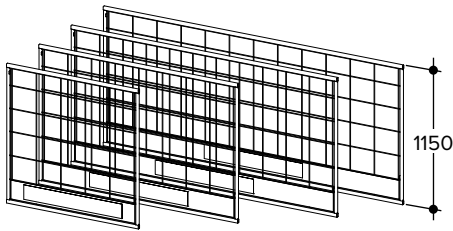

* For sale only.

TOPMAX EXTRAGUARD Socket Base (M)	617605	1.20
------------------------------------------	---------------	-------------

Used to attach a EXTRAGUARD Guardrail Post to TOPMAX Floor Tables.
It is secured using a Centering Nut 100 per each socket.
Maximum allowable post spacing is 2.40 m.
See page 75.

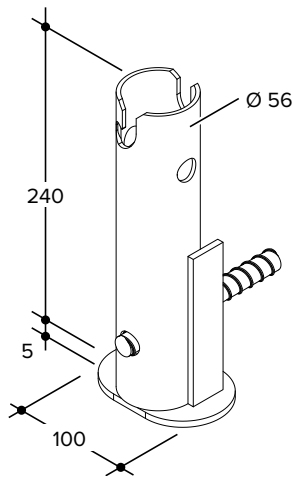

EXTRAGUARD Guardrail Post 1.25 m	617588	4.70
-----------------------------------------	---------------	-------------

Used in conjunction with the TOPMAX EXTRAGUARD Socket Base to provide edge protection at the leading edges of the TOPMAX Floor Tables.
See page 75.

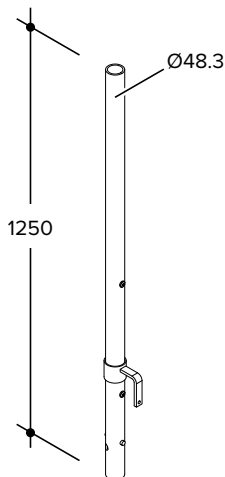

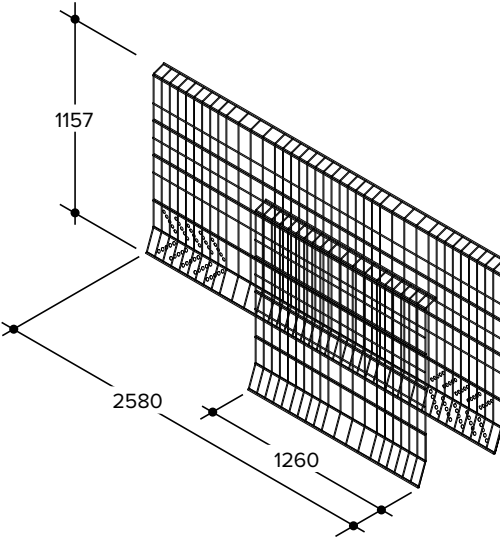
	Component	Part code	Weight [kg]
	EXTRAGUARD Panel 1.15 x 1.30 m	617526	11.30
	EXTRAGUARD Panel 1.15 x 2.60 m	617535	22.00
<p>Used in conjunction with the EXTRAGUARD Guardrail Posts to provided edge protection at the leading edges of the TOPMAX Floor Tables. See page 75.</p>			

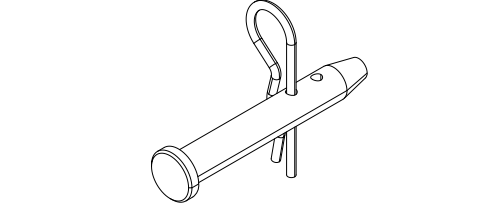
	Pivot Pin 16 x 100 mm	590850	0.20
	Safety Pin	590851	0.01
<p>Used to secure the EXTRAGUARD Guardrail Post when lifting the TOPMAX tables. See page 75.</p>			

4.8 Table transport

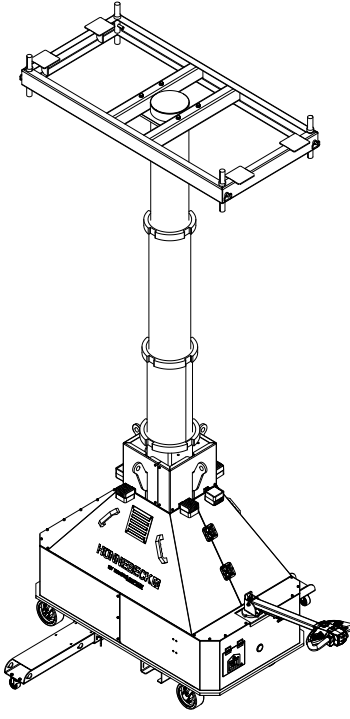
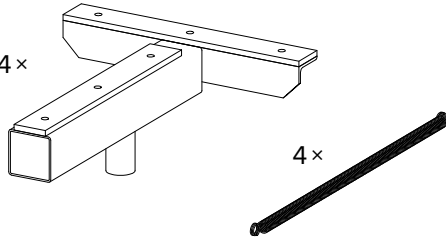
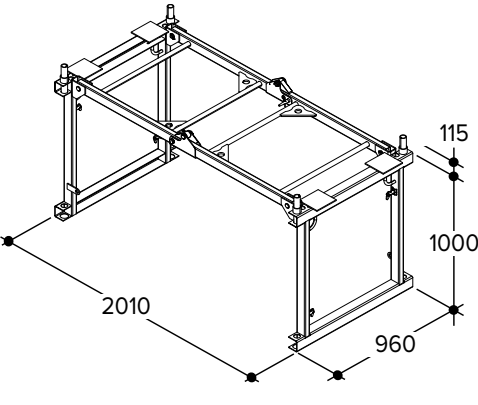
	Component	Part code	Weight [kg]
	<p>Multi Mover</p> <p>Used to lift, lower and move TOPMAX Floor Tables between 2.00 m and 4.50 m high. Can be used with Extension Frames for heights of up to 7.50 m.</p> <p>Dimensions: H = 1.98 m L = 1.80 m D = 1.00 m (1.80 m with the extended outriggers).</p> <p>Positioning Tubes and Locking Pins are included.</p> <p>TOPMAX Turning Heads and Readjusting Springs must be ordered separately.</p> <p>See page 111.</p>	<p>607150</p>	<p>1,630.00</p>
	<p>Turning Head Set</p> <p>Used with the Multi Mover to provide a support surface.</p> <p>Includes 4no. TOPMAX Turning Head (code:603237) and 4no. Readjusting Spring (code:603303).</p>	<p>607160</p>	<p>28.72</p>
	<p>Multi Mover Extension Frame</p> <p>Used with the Multi Mover to allow for higher tables to be moved.</p> <p>For TOPMAX Floor Tables between 4.50 m and 7.50 m the use of the Multi Mover Extension Frame is required.</p> <p>Not required for GASS frames.</p> <p>2no. Guardrail 200 need to be ordered separately.</p> <p>Positioning Tube included.</p> <p>If needed, 4no. TOPMAX Turning Heads and 4no. TOPMAX Readjusting Springs are to be ordered separately.</p> <p>4no. Multi Mover Locking Pins (code:607156) to secure the frame to the Multi Mover, need to be ordered separately.</p> <p>See page 122</p>	<p>607152</p>	<p>103.19</p>

	Component	Part code	Weight [kg]
	<p>Guardrail 200</p> <p>Used to brace the Multi Mover Extension Frame.</p> <p>Each frame requires 2no. guardrails.</p> <p>See page 122.</p>	<p>154080</p>	<p>3.55</p>
	<p>TOPMAX Lifting Jack Carriage</p> <p>Used in pairs in conjunction with MODEX parts, which forms a Positioning Unit, to move TOPMAX Floor Tables.</p> <p>For floor heights lower than 3.00 m.</p> <p>See page 136.</p>	<p>603226</p>	<p>87.35</p>
	<p>TOPMAX Lifting Jack Carriage 750</p> <p>Used in pairs in conjunction with MODEX parts, which forms a Positioning Unit 750, to move TOPMAX Floor Tables.</p> <p>For floor heights up to 7.50 m.</p> <p>See page 137.</p>	<p>607111</p>	<p>219.13</p>
	<p>TOPMAX Electric Table Jack Lift</p> <p>A electrically driven device for transport and positioning of TOPMAX Floor Tables on even and load-carrying slabs.</p> <p>Safe Working Load: 12.50 kN.</p> <p>See page 142.</p>	<p>603600</p>	<p>1596.71</p>

4.9 Lifting

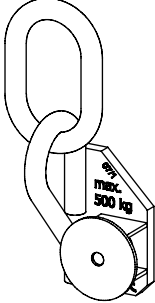
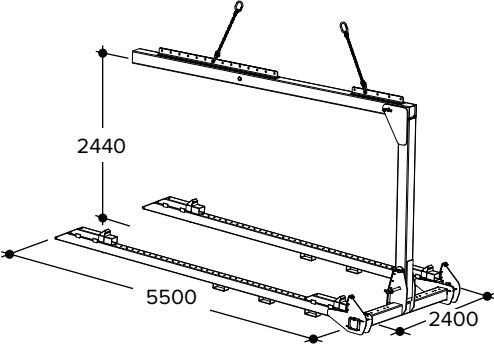
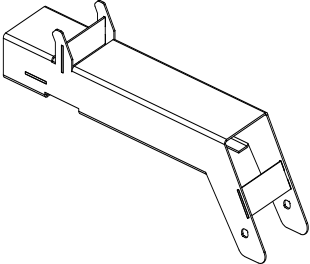
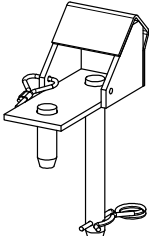
	Component	Part code	Weight [kg]
 <p>A line drawing of a crane suspension component. It features a large metal ring at the top, a smaller ring below it, and a rectangular metal plate with a circular hole at the bottom. The plate has the text 'max 500 kg' printed on it.</p>	<p>TOPMAX Crane Suspension</p> <p>Used in groups of four units, it allows to use a crane to load and unload a single TOPMAX Floor Table or bundles of up to 4no. tables.</p> <p>Safe Working Load: 5.00 kN (per unit).</p> <p>See page 145.</p>	<p>603050</p>	<p>1.71</p>
 <p>A line drawing of a TOPMAX Lifting Fork. It is a long, narrow metal structure with two vertical supports on one side. Dimensions are indicated: a height of 2440 mm, a length of 5500 mm, and a width of 2400 mm.</p>	<p>TOPMAX Lifting Fork</p> <p>The TOPMAX Lifting Fork is used to transport TOPMAX Floor Tables by crane. Two tables up to 26.00 m² can be moved in just one pick.</p> <p>Supplied with 2no. Lifting Stopends and 4no. TOPMAX Spacer Plugs.</p> <p>Working Load Limit: 12.50 kN.</p> <p>See page 148.</p>	<p>603074</p>	<p>961.97</p>
 <p>A line drawing of a TOPMAX Spacer Plug Adapter. It is a long, narrow metal plate with a raised section on one end and a locking mechanism on the other.</p>	<p>TOPMAX Spacer Plug Adapter</p> <p>Used with the TOPMAX Lifting Fork for longitudinal transport of TOPMAX Floor Tables 1.80 x 5.40 m.</p> <p>This item is not supplied with the TOPMAX Lifting Fork and needs to be ordered separately. An additional TOPMAX Locking Pin is required to be ordered separately as well.</p>	<p>607200</p>	<p>9.82</p>
 <p>A line drawing of a Lifting Stopend. It is a small metal component with a flat top surface and a vertical post extending downwards from the center.</p>	<p>Lifting Stopend</p> <p>Used when the TOPMAX Lifting Fork is placed laterally to move 2no. TOPMAX tables.</p>	<p>603097</p>	<p>1.94</p>

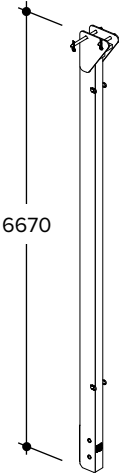
	Component	Part code	Weight [kg]
	<p>TOPMAX Lifting Fork Vertical Post 600</p> <p>The UG Vertical Post 600 is an accessory part for the TOPMAX Lifting Fork. It is used when the opening width of the TOPMAX Lifting Fork (2.40 m) is not sufficient to access TOPMAX tables from above by crane, i.e. at high parapets and obstacles or when removing tables at double floors.</p> <p>With the UG Vertical Post 600, the TOPMAX Lifting Fork can have a maximum width of 5.90 m.</p> <p>Working Load Limit: 12.50 kN.</p> <p>See page 149.</p>	603596	421.47

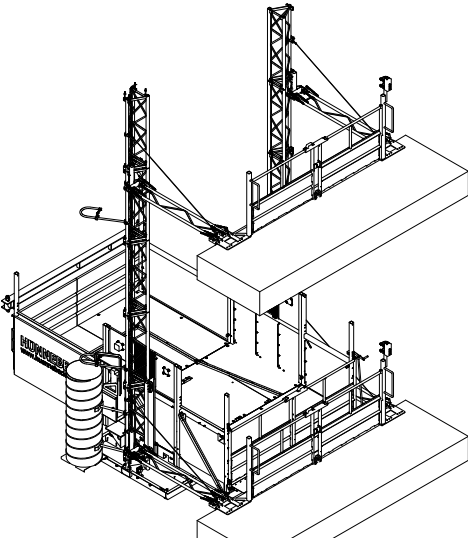
	<p>TOPMAX Table Lifting System</p> <p>Used to move TOPMAX tables between floors. In the basic configuration a height of 7.00 m can be reached.</p> <p>Basic system consisting of:</p> <ul style="list-style-type: none"> 1no. basic unit 2no. pylon anchors 2no. cable guide bracket 1no. floor level stop bracket 12no. triangle lattice tower 2no. end switch guide plate <p>Maximum load carrying capacity:</p> <ul style="list-style-type: none"> during transport = 1,685.00 kg during loading = 2,370.00 kg. <p>* Not readily available.</p>	603500	4022.00
------------------------------------------------------------------------------------	-----------------------------------------------------------------------------------------------------------------------------------------------------------------------------------------------------------------------------------------------------------------------------------------------------------------------------------------------------------------------------------------------------------------------------------------------------------------------------------------------------------------------------------------------------------------------------------------------------------------------------------------------	---------------	----------------

4.10 Tools

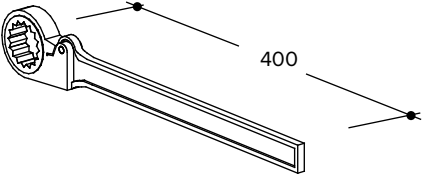
	Component	Part code	Weight [kg]
	<p>MANTO Ratchet</p> <p>Used to adjust the Centering Nut 100 in a fast, easy and protectively way.</p> <p>W.a.f.: 36.</p>	408780	1.00

4.11 Storage

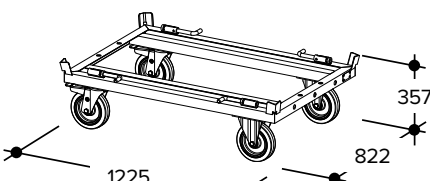
	Component	Part code	Weight [kg]
	<p>Euro Trolley</p> <p>Used to manually manoeuvre approved HÜNNEBECK transport equipment.</p> <p>The Euro Trolley has two lockable swivel castors.</p> <p>Safe Working Load: 1,300 kg</p>	<p>607610</p>	<p>39.57</p>

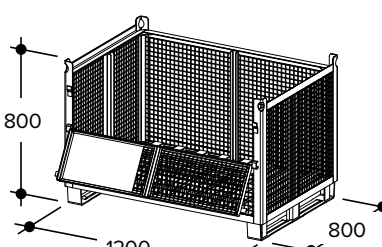

For more information regarding the Euro Trolley refer to the separate Operating Instructions!

	<p>Euro Lattice Box</p> <p>Lattice box used to store and transport small items by crane.</p> <p>Can be moved using the Euro Trolley.</p> <p>Safe Working Load: 1,200 kg.</p>	<p>548480</p>	<p>68.79</p>
------------------------------------------------------------------------------------	-------------------------------------------------------------------------------------------------------------------------------------------------------------------------------------	----------------------	---------------------

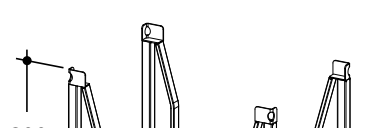
	<p>Euro Stacking Frame 120/80</p> <p>Stacking frame used to store and transport materials by crane.</p> <p>Can be moved using the Euro Trolley.</p> <p>Safe Working Load: 1,200 kg.</p>	<p>553689</p>	<p>54.47</p>
-------------------------------------------------------------------------------------	------------------------------------------------------------------------------------------------------------------------------------------------------------------------------------------------	----------------------	---------------------

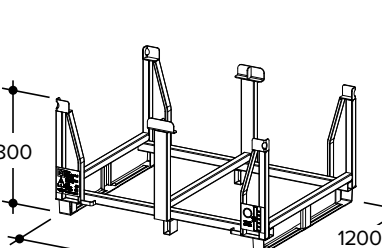
	<p>Euro Stacking Frame 160/120</p> <p>Stacking frame used to store and transport materials by crane.</p> <p>Safe Working Load: 1,200 kg.</p>	<p>566494</p>	<p>84.02</p>
-------------------------------------------------------------------------------------	-----------------------------------------------------------------------------------------------------------------------------------------------------	----------------------	---------------------

Component	Part code	Weight [kg]
-----------	-----------	-------------

Uni Mesh Panel Rack

605558

65.74

Rack used to store and transport by crane up to 50no. Universal Mesh Panels
 Can be moved using the Euro Trolley.
 Safe Working Load: 1,050 kg.

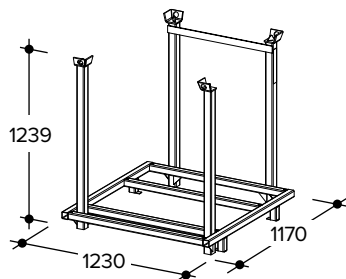

Component	Part code	Weight [kg]
-----------	-----------	-------------

PROTECTO Mesh Panel Rack

608375

97.94

The PROTECTO Mesh Panel Rack is used to store and transport up to 60no. PROTECTO Mesh Panels.

When stacking the PROTECTO Mesh Panels, make sure that they are alternately placed in the rack turned by 180 degrees and secured by the Insertion Tube.

Up to 2no. loaded racks can be stacked on top of each other.

The PROTECTO Mesh Panel Rack can be safely transported by forklift or crane.

For more information refer to the Product Information.

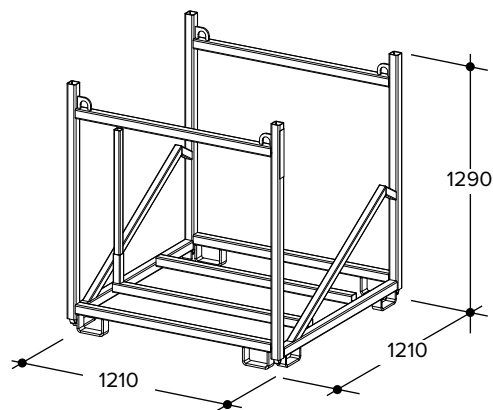

5 Applications

5.1 TOPMAX Floor Tables

5.1.1 TOPMAX Floor Table 2.4 x 5.4 m

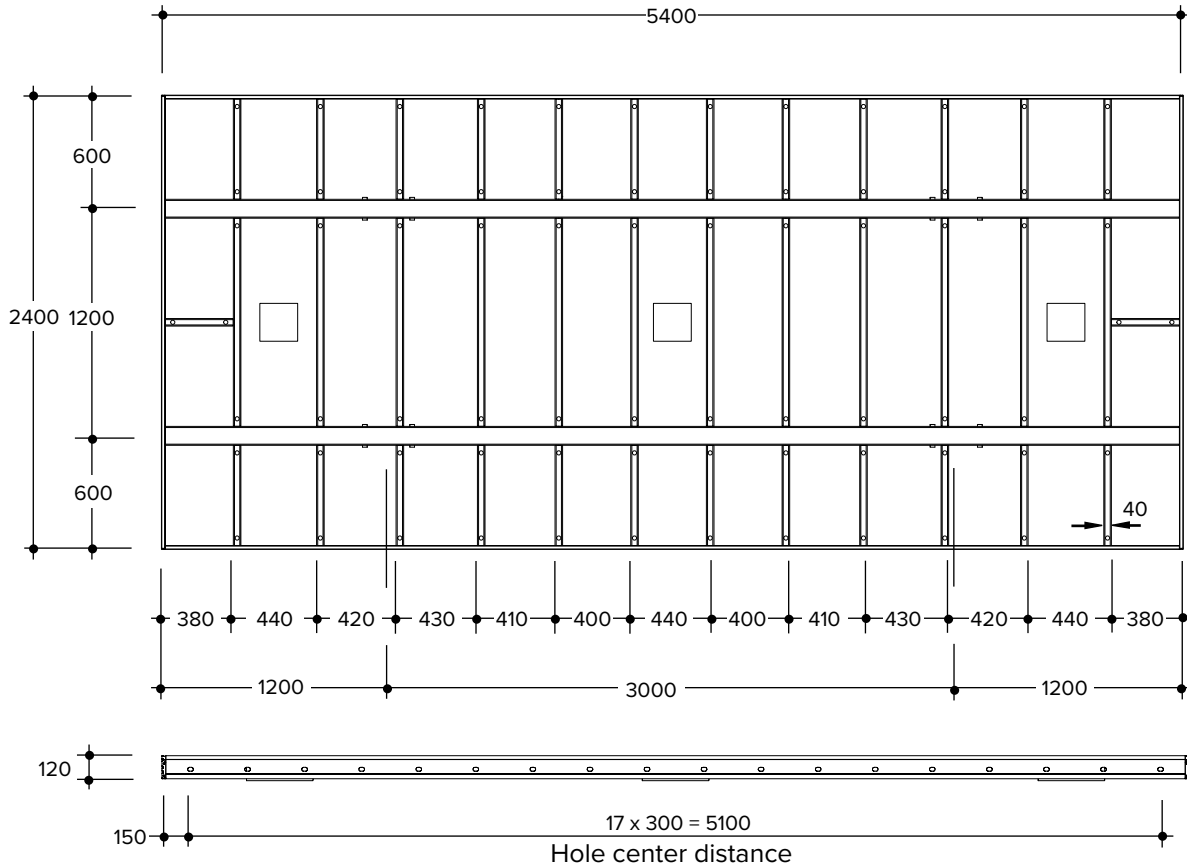

TOPMAX Floor Table 2.4 x 5.4 m	
DIN EN 12812	
Slab thickness d [mm]	Prop load A [kN]
100	14.59
150	18.64
200	22.69
250	26.74
300	30.79
350	35.25
400	39.70
450	44.16
500	48.61

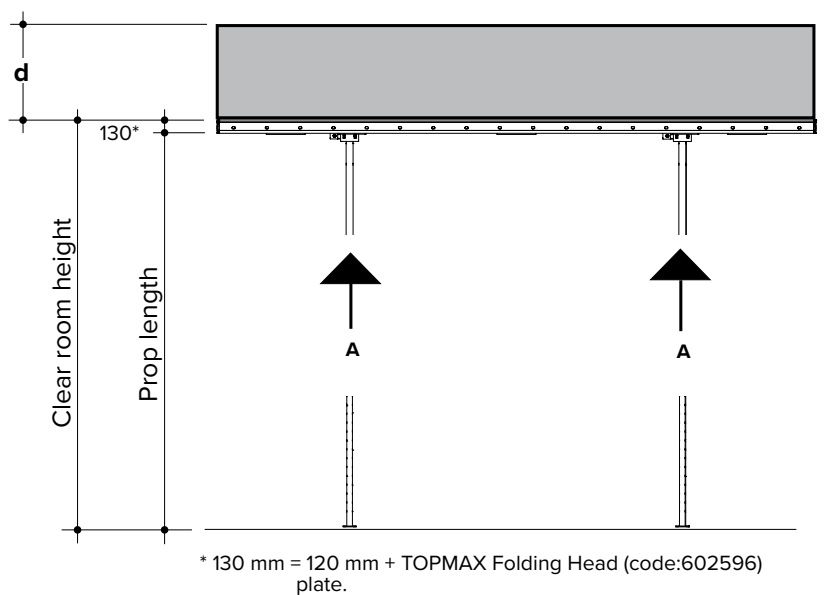

WARNING

Risk of collapse and/or serious injury!

Check additional prop loads at the infill areas, see section regarding infills starting on page 87.

5.1.2 TOPMAX Floor Table 1.8 x 5.4 m

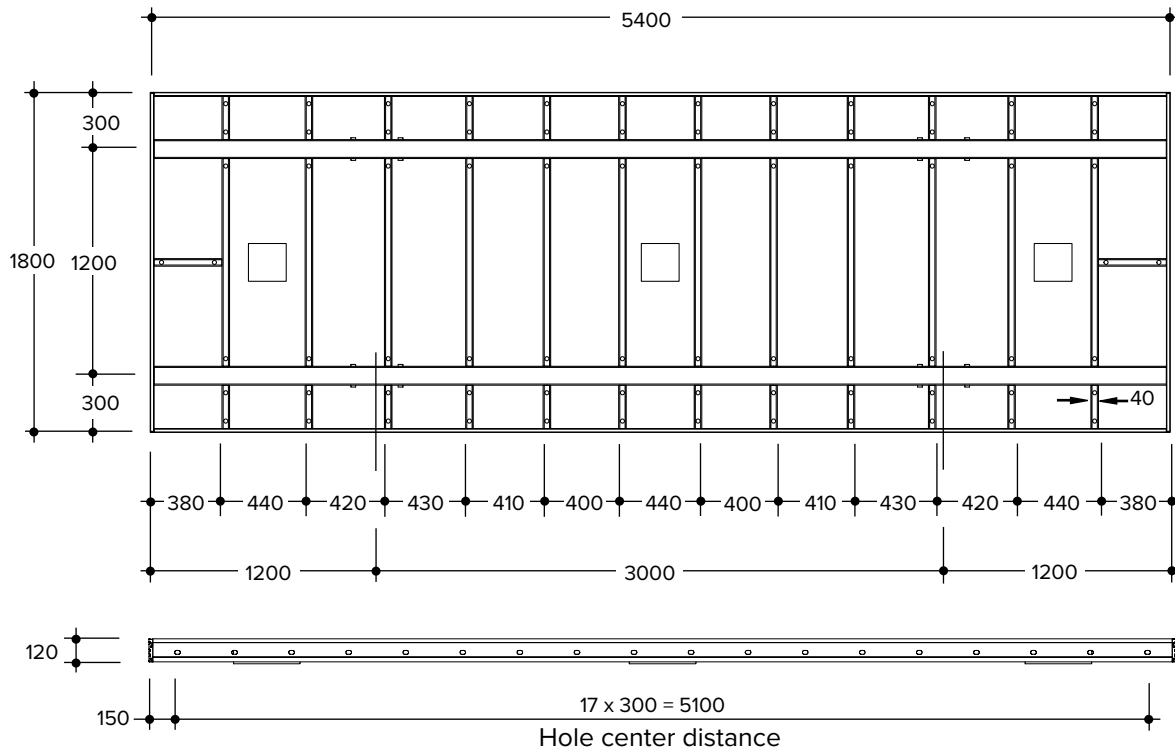

TOPMAX Floor Table 1.8 x 5.4 m	
DIN EN 12812	
Slab thickness d [mm]	Prop load A [kN]
100	11.15
150	14.19
200	17.23
250	20.26
300	23.30
350	26.64
400	29.98
450	33.32
500	36.67

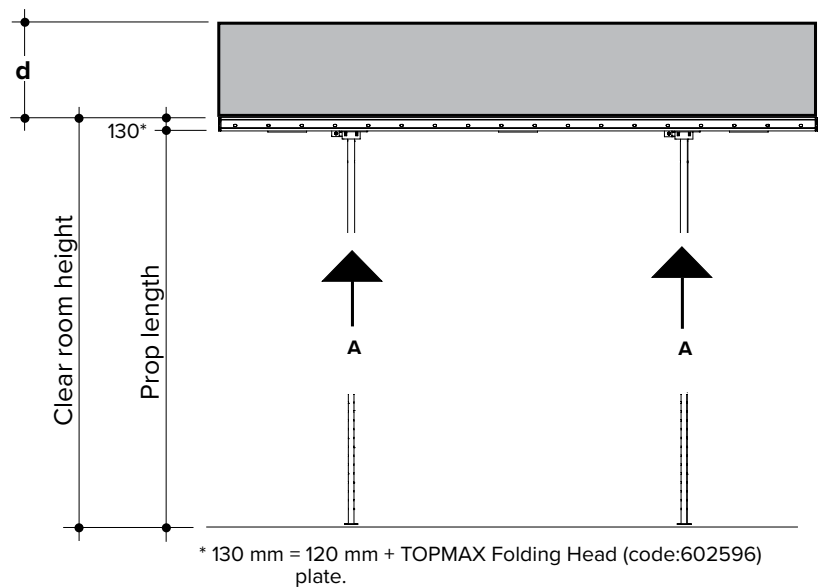

WARNING

Risk of collapse and/or serious injury!

Check additional prop loads at the infill areas, see section regarding infills starting on page 87.

5.1.3 Connecting TOPMAX Floor Tables

Tables are connected to each other at the external profiles using Centering Tension Bolts (code:479264) and Centering Nut 100 (code:469566) (see typical section below).

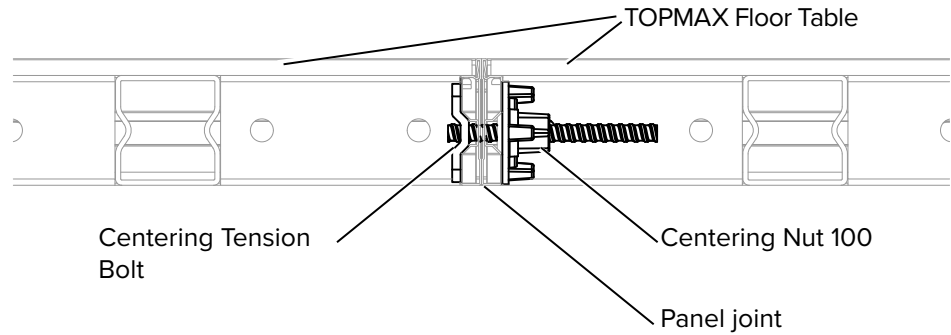

Typical connection positions

Typically the TOPMAX Floor Tables are connected to each other using the positions shown below, however this may vary depending on the job specific requirements.

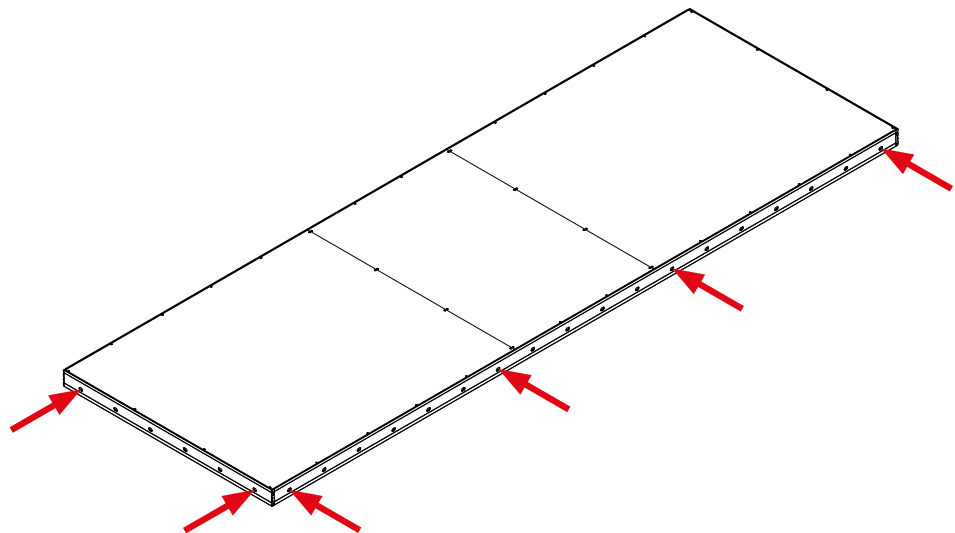

5.2 Props and bearings

5.2.1 EUROPLUSnew props

Extending / retracting the EUROPLUSnew Props



WARNING

Risk of collapse and/or serious injury!

Do not release the collar when the props are under compression.

Step 1 Push the quick release bolt fully to release the inner tube.

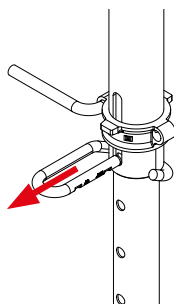

Step 2 Slide the inner tube to for rough prop length adjustment.

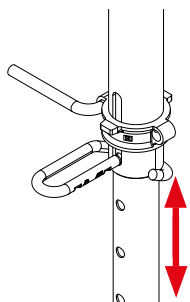

Step 3 Insert the quick release bolt back into the inner tube at the appropriate hole position.

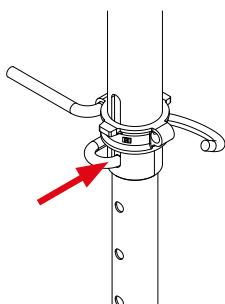

Step 4 Rotate the collar for exact prop length adjustment

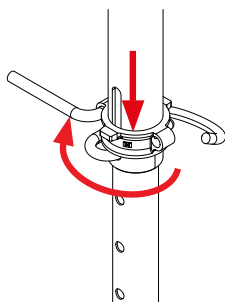

NOTICE

Risk of damage to components!

Ensure that the side of the quick release bolt is not in contact with the threaded part on the prop (see below). This will cause damage to the thread once the prop is under load.

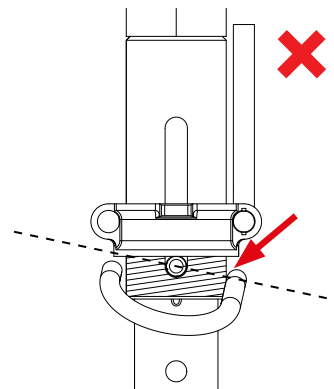
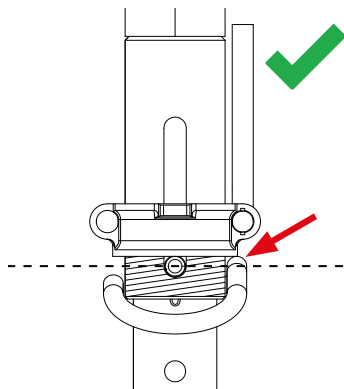

EUROPLUS^{new} prop orientation

Please note the correct orientation of the EUROPLUS^{new} props.

Inner tube down

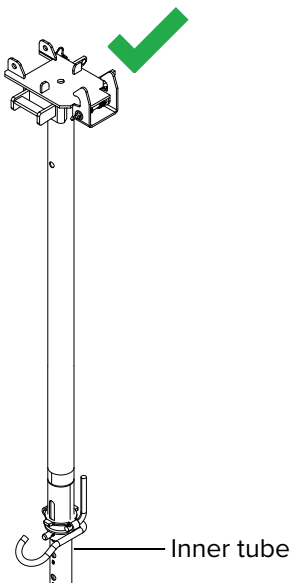

Inner tube up

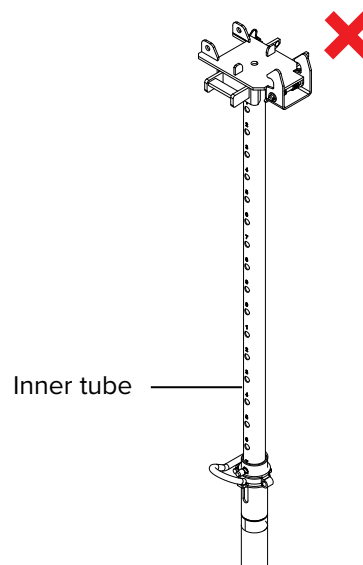

Also note the correct orientation of the EUROPLUS^{new} props in relation to the TOPMAX Folding Head (code:602596).

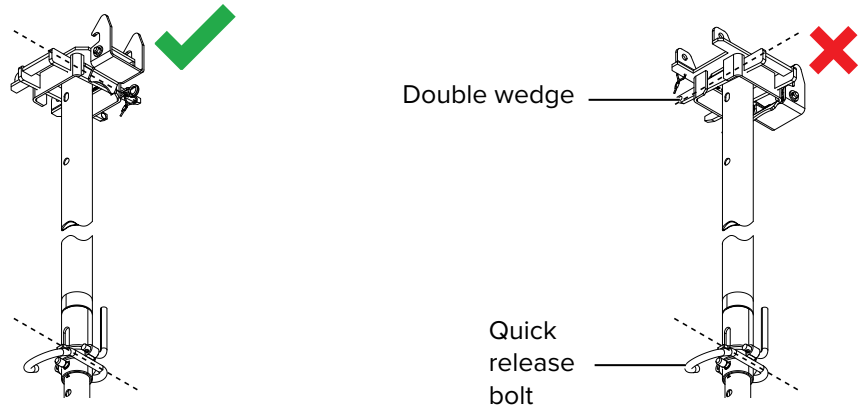

The EUROPLUS^{new} props must be positioned so that the quick release bolts face away from the centre of the table as shown below, to prevent the quick release bolt from disengaging when swinging the props (lifting the table) and to allow the Multi Mover (code:607150) to be able to be positioned under the table.

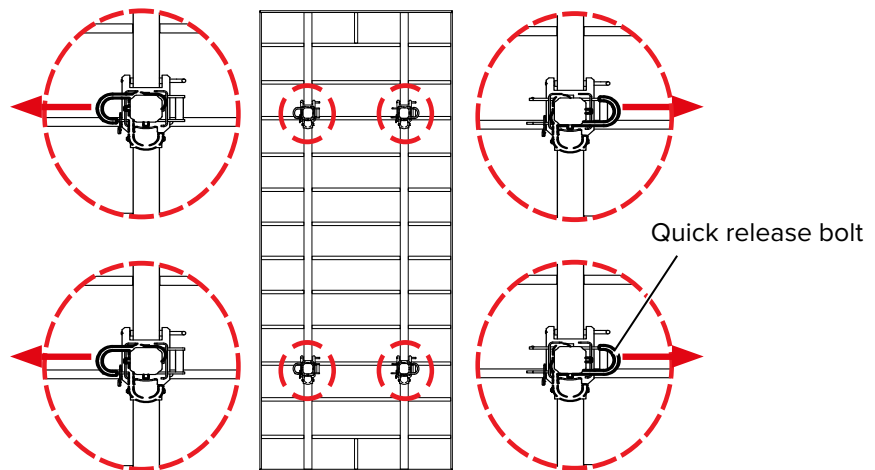

Load tables EUROPLUSnew Prop (inner tube down)

Permitted max. clear room height [m] for slab thickness d [mm] using 2.4 x 5.4 m tables										
d [mm]		150	200	250	300	350	400	450	500	
N [kN] DIN EN 12812		18.64	22.69	26.74	30.79	35.25	39.70	44.16	48.61	
Prop type	l [min]	Head bearing condition								
20-250	1.63	Head hinged	2.62	2.62	2.42	-	-	-	-	-
		Head fixed	2.62	2.62	2.62	-	-	-	-	-
20-300	1.88	Head hinged	3.12	3.12	3.02	2.82	2.72	-	-	-
		Head fixed	3.12	3.12	3.12	3.12	3.12	-	-	-
20-350	2.14	Head hinged	3.62	3.62	3.62	-	-	-	-	-
		Head fixed	3.62	3.62	3.62	-	-	-	-	-
20-400	2.40	Head hinged	4.12	4.12	3.92	3.82	-	-	-	-
		Head fixed	4.12	4.12	4.12	4.12	-	-	-	-
20-550	3.19	Head hinged	5.62	5.62	5.32	5.02	4.82	-	-	-
		Head fixed	5.62	5.62	5.62	5.62	5.32	-	-	-
30-150	1.10	Head hinged	1.62	1.62	1.62	1.62	1.62			
		Head fixed	1.62	1.62	1.62	1.62	1.62			
30-250	1.63	Head hinged	2.62	2.62	2.62	2.62	-	-	-	-
		Head fixed	2.62	2.62	2.62	2.62	-	-	-	-
30-300	1.88	Head hinged	3.12	3.12	3.12	3.12	3.02	-	-	-
		Head fixed	3.12	3.12	3.12	3.12	3.12	-	-	-
30-350	2.14	Head hinged	3.62	3.62	3.62	3.62	3.52	3.22	3.32	2.82
		Head fixed	3.62	3.62	3.62	3.62	3.62	3.62	3.62	3.62
30-400	2.40	Head hinged	4.12	4.12	4.12	4.12	4.12	-	-	-
		Head fixed	4.12	4.12	4.12	4.12	4.12	-	-	-

Permitted max. clear room height [m] for slab thickness d [mm] using 1.8 x 5.4 m tables										
d [mm]		150	200	250	300	350	400	450	500	
N [kN] DIN EN 12812		14.19	17.23	20.26	23.30	26.64	29.98	33.32	36.67	
Prop type	l [min]	Head bearing condition								
20-250	1.63	Head hinged	2.62	2.62	2.62	2.62	2.42	-	-	-
		Head fixed	2.62	2.62	2.62	2.62	2.42	-	-	-
20-300	1.88	Head hinged	3.12	3.12	3.12	3.12	3.02	2.82	2.72	2.52
		Head fixed	3.12	3.12	3.12	3.12	3.12	3.12	3.12	3.02
20-350	2.14	Head hinged	3.62	3.62	3.62	3.62	3.62	-	-	-
		Head fixed	3.62	3.62	3.62	3.62	3.62	-	-	-
20-400	2.40	Head hinged	4.12	4.12	4.12	4.12	4.02	3.82	-	-
		Head fixed	4.12	4.12	4.12	4.12	4.12	4.12	-	-
20-550	3.19	Head hinged	5.62	5.62	5.62	5.62	5.33	5.12	4.92	4.82
		Head fixed	5.62	5.62	5.62	5.62	5.62	5.62	5.52	5.42
30-150	1.10	Head hinged	1.62	1.62	1.62	1.62	1.62	1.62	1.62	1.62
		Head fixed	1.62	1.62	1.62	1.62	1.62	1.62	1.62	1.62
30-250	1.63	Head hinged	2.62	2.62	2.62	2.62	2.62	2.62	2.62	-
		Head fixed	2.62	2.62	2.62	2.62	2.62	2.62	2.62	-
30-300	1.88	Head hinged	3.12	3.12	3.12	3.12	3.12	3.12	3.12	3.12
		Head fixed	3.12	3.12	3.12	3.12	3.12	3.12	3.12	3.12
30-350	2.14	Head not fixed	3.62	3.62	3.62	3.62	3.62	3.62	3.62	3.52
		Head fixed	3.62	3.62	3.62	3.62	3.62	3.62	3.62	3.62
30-400	2.40	Head hinged	4.12	4.12	4.12	4.12	4.12	4.12	4.12	4.12
		Head fixed	4.12	4.12	4.12	4.12	4.12	4.12	4.12	4.12

Load tables EUROPLUSnew Prop - Line D

EUROPLUSnew with or without fixed bearing condition at head										
Permitted prop loads [kN] of Line D - in accordance with the type approval "Inner tube down"										
L [m]	20-250		20-300		20-350		20-400		20-550	
	Head hinged	Head fixed	Head hinged	Head fixed	Head hinged	Head fixed	Head hinged	Head fixed	Head hinged	Head fixed
1.10										
1.20										
1.30										
1.40										
1.50	27.76	27.76								
1.60	27.76	27.76								
1.70	27.76	27.76								
1.80	27.76	27.76	38.48	38.48						
1.90	27.76	27.76	38.48	38.48						
2.00	27.76	27.76	38.48	38.48	27.76	27.76				
2.10	27.76	27.76	38.48	38.48	27.76	27.76				
2.20	27.76	27.76	38.48	38.48	27.76	27.76				
2.30	27.76	27.76	38.48	38.48	27.76	27.76	30.97	30.97		
2.40	26.52	27.76	38.48	38.48	27.76	27.76	30.97	30.97		
2.50	24.73	27.76	38.48	38.48	27.76	27.76	30.97	30.97		
2.60			35.55	38.48	27.76	27.76	30.97	30.97		
2.70			32.42	38.48	27.76	27.76	30.97	30.97		
2.80			29.69	38.48	27.76	27.76	30.97	30.97		
2.90			26.95	37.15	27.76	27.76	30.97	30.97		
3.00			24.21	35.50	27.76	27.76	30.97	30.97		
3.10					27.76	27.76	30.97	30.97	38.48	38.48
3.20					27.76	27.76	30.97	30.97	38.48	38.48
3.30					27.76	27.76	30.97	30.97	38.48	38.48
3.40					27.76	27.76	30.97	30.97	38.48	38.48
3.50					27.76	27.76	30.97	30.97	38.48	38.48
3.60							30.97	30.97	38.48	38.48
3.70							30.97	30.97	38.48	38.48
3.80							28.95	30.97	38.48	38.48
3.90							26.84	30.97	38.48	38.48
4.00							24.73	30.97	38.48	38.48
4.10									38.48	38.48
4.20									38.48	38.48
4.30									38.48	38.48
4.40									38.48	38.48
4.50									38.48	38.48
4.60									38.48	38.48
4.70									36.71	38.48
4.80									34.12	38.48
4.90									31.71	38.38
5.00									30.29	38.38
5.10									28.87	38.38
5.20									27.45	38.38
5.30									26.03	37.42
5.40									24.60	34.68
5.50									23.18	31.94

Load tables EUROPLUSnew Prop - Line E

EUROPLUSnew with or without fixed bearing condition at head										
Permitted prop loads [kN] of Line E - in accordance with the type approval "Inner tube down"										
L [m]	30-150		30-250		30-300		30-350		30-400	
	Head hinged	Head fixed	Head hinged	Head fixed	Head hinged	Head fixed	Head hinged	Head fixed	Head hinged	Head fixed
1.10	38.48	38.48								
1.20	38.48	38.48								
1.30	38.48	38.48								
1.40	38.48	38.48								
1.50	38.48	38.48	33.33	33.33						
1.60			33.33	33.33						
1.70			33.33	33.33						
1.80			33.33	33.33	37.21	37.21				
1.90			33.33	33.33	37.21	37.21				
2.00			33.33	33.33	37.21	37.21	49.95	49.95		
2.10			33.33	33.33	37.21	37.21	49.95	49.95		
2.20			33.33	33.33	37.21	37.21	49.95	49.95		
2.30			33.33	33.33	37.21	37.21	49.95	49.95	38.48	38.48
2.40			33.33	33.33	37.21	37.21	49.95	49.95	38.48	38.48
2.50			33.33	33.33	37.21	37.21	49.95	49.95	38.48	38.48
2.60					37.21	37.21	49.95	49.95	38.48	38.48
2.70					37.21	37.21	49.95	49.95	38.48	38.48
2.80					37.21	37.21	48.56	49.95	38.48	38.48
2.90					37.21	37.21	47.07	49.95	38.48	38.48
3.00					36.58	37.21	45.58	49.95	38.48	38.48
3.10							44.09	49.95	38.48	38.48
3.20							41.73	49.95	38.48	38.48
3.30							39.15	49.95	38.48	38.48
3.40							36.58	49.95	38.48	38.48
3.50							34.00	49.95	38.48	38.48
3.60									38.48	38.48
3.70									38.48	38.48
3.80									38.48	38.48
3.90									38.48	38.48
4.00									38.48	38.48

The load tables shown are applicable to EUROPLUSnew props when used as the main support for the TOPMAX Floor Tables and attached to the connection points on the main profiles of the table. Load capacity of EUROPLUSnew props for infills or extension tables can be taken from TOPFLEX User Guide."

The term "head fixed" (top fixed bearing) describes a calculation method acc. to DIN EN 1065 for steel props. In regions where this method is not approved, consider the values for head hinged bearing.

5.2.2 Tripods

For interim storage of the TOPMAX Floor Tables, slide in the inner tubes of the props to the permitted length and equip all props with Uni Tripods (code:587377).

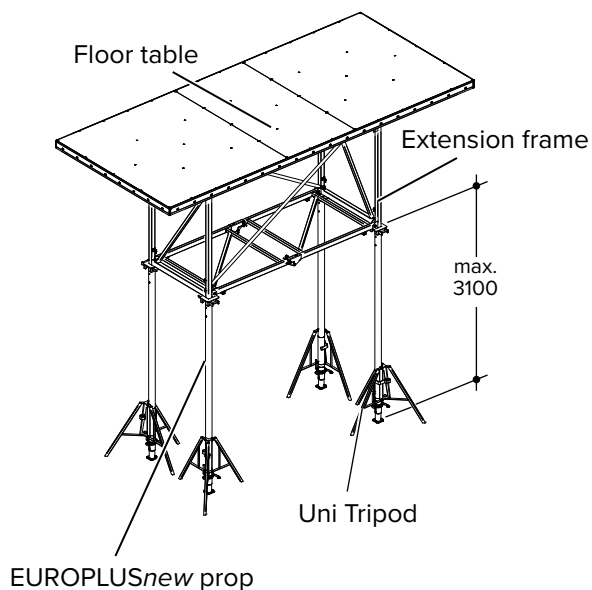
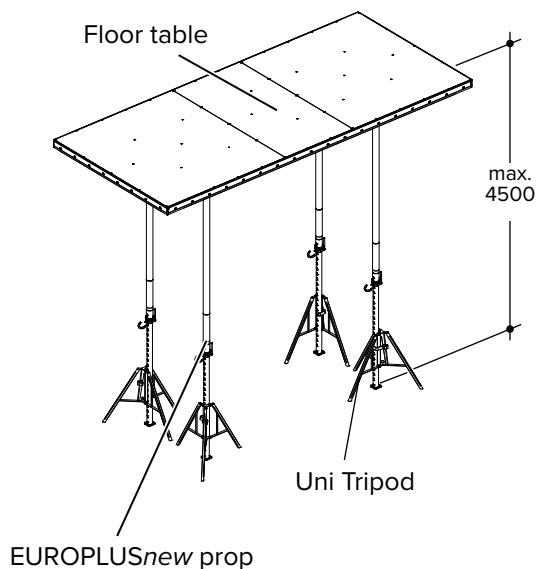

WARNING

Risk of collapse and/or serious injury!

Do not exceed the permitted prop length.

- With Uni Tripod (code:587377): 4.50 m
- With Uni Tripod (code:587377) + TOPMAX Extension Frame (code:603479): 3.10 m

During strong winds (wind force 6, wind speed: 14 m/s) the TOPMAX Floor Tables must be secured using suitable measures.

5.2.3 TOPMAX Floor Table propping

The following section details the application of props when used on single TOPMAX tables. For the use of props on infill areas, see page 87.

It is assumed that at the start of the assembly of any props, the TOPMAX Floor Table is resting on top of trestles or other suitable support. The TOPMAX Floor Tables must be secured against displacement or overturning.



Customer to provide secure access to allow work on the underside and sides of the TOPMAX Floor Tables.

TOPMAX Folding Head and EUROPLUSnew props

Step 1 Align the hole of the TOPMAX Folding Head (code:602596) with the connection point on the TOPMAX Floor Table profile.

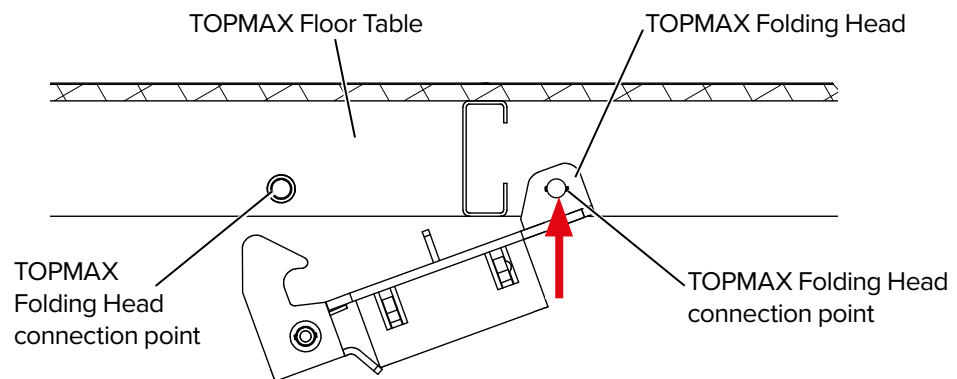

Step 2 Insert the TOPMAX Locking Pin (code:603067) through the profile to secure the head.

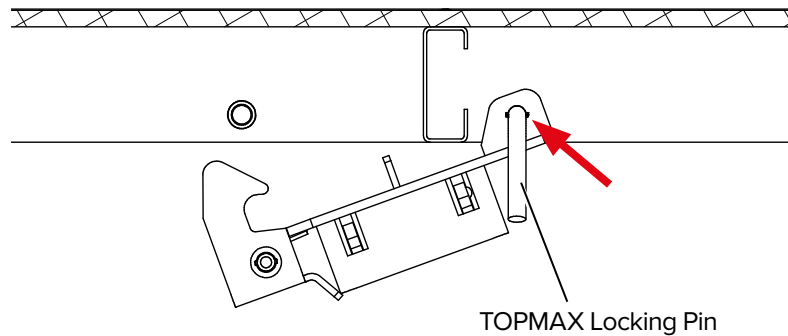

When attaching the Locking Pin (code:603067) rotate the handle to avoid clashing with the double wedge of the Folding Head (code:602596) and the internal profiles of the TOPMAX Floor Table.

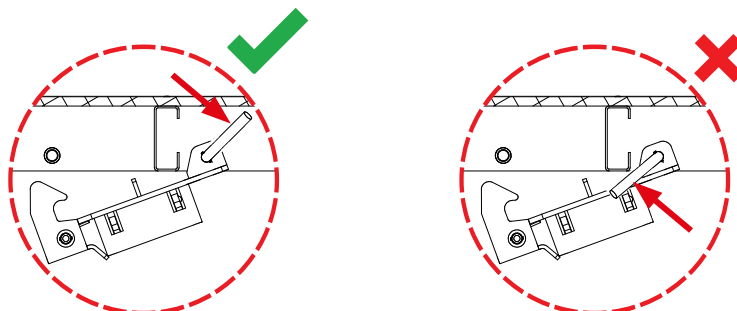

- Step 3** Pull out the double wedge of the folding head.
For clarity, in steps 3–5, the table is not shown and the folding head is in a horizontal position.

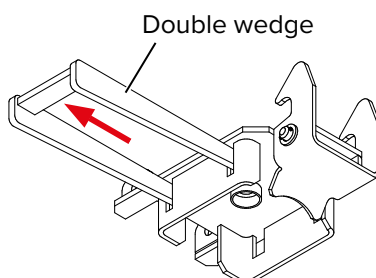

- Step 4** Extend the EUROPLUS^{new} prop to the required length, see page 29.

- Step 5** Insert the EUROPLUS^{new} prop into the folding head, see page 30.

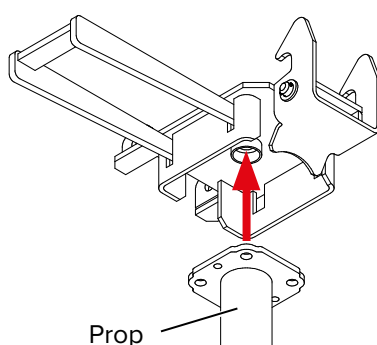

- Step 6** Push and strike the double wedge to ensure prop is securely attached.

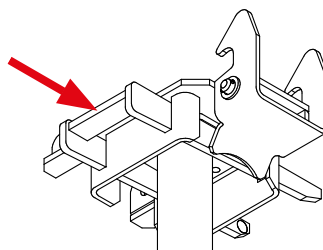

- Step 7** Swivel the head until the claw locks into the connection point on the TOPMAX Floor Table profile.

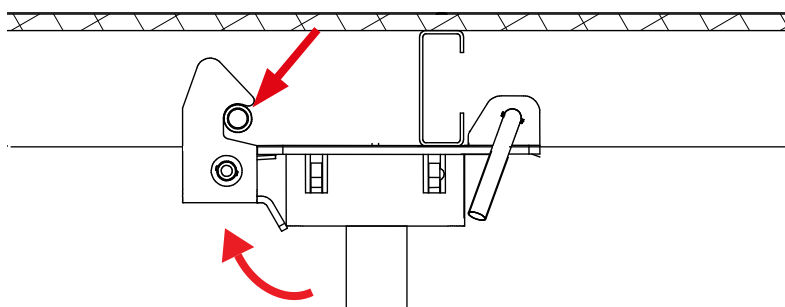

- Step 8** Repeat steps 1–7 for the other folding head positions.



All four TOPMAX Folding Heads (code:602596) must be aligned in the same direction when swivelling props are to be used, for example when tables are to be moved over parapets.

TOPMAX Head Adapter and EUROPLUSnew props

The TOPMAX Head Adapter (code:603442) allows for a prop to be used on a non-standard position along the main profile of the TOPMAX Floor Table, however a separate structural analysis is required.

- Step 1** Turn each wing nut to extend the claws of the TOPMAX Head Adapter (code:603442).

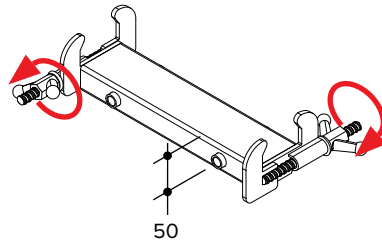

- Step 2** Position the adapter on the required location along the main profile of the TOPMAX Floor Table and tighten the wing nuts again.

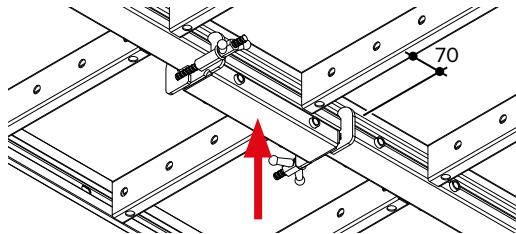

It is not possible to operate the wing nut in the area of the panel ribs. Therefore it is necessary to keep a distance between the panel rib and the prop connection of approximately 70 mm.

- Step 3** Attach the TOPMAX Folding Head (code:602596) to the TOPMAX Head Adapter (code:603442). See steps 1–7 on page 36. See also page 29 for information regarding the props.

- Step 4** Attach an EUROPLUSnew prop to the TOPMAX Folding Head and bring it into the resting position. See steps 3-7 of section starting on page 36.

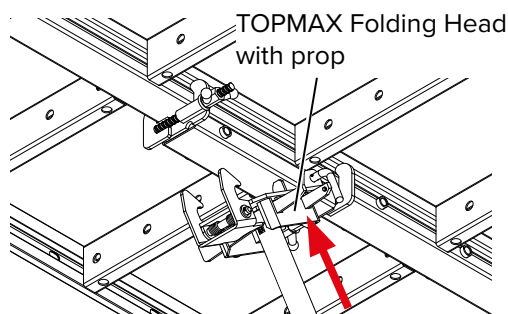

- Step 5** Swivel the TOPMAX Folding Head (code:602596) until the claw locks into the connection point on the TOPMAX Head Adapter (code:603442).

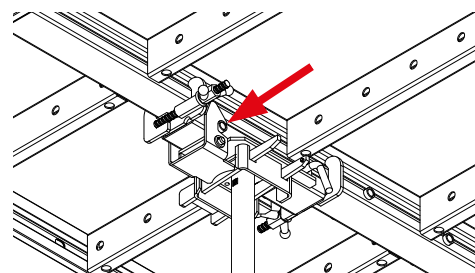

TOPMAX GASS Multi Adapter and GASS Legs



A program to retrofit existing GASS outer legs with the double latch arrangement is underway, during this retrofit period both single and double latch outer legs will be in our stocks. Both options are interchangeable however the separate Safety Latch (code:718907) must be used on all single latch legs when lifting or flying.



For more information regarding the GASS system, please refer to the GASS User Guide.

Step 1 Extend the GASS Legs to the required length.

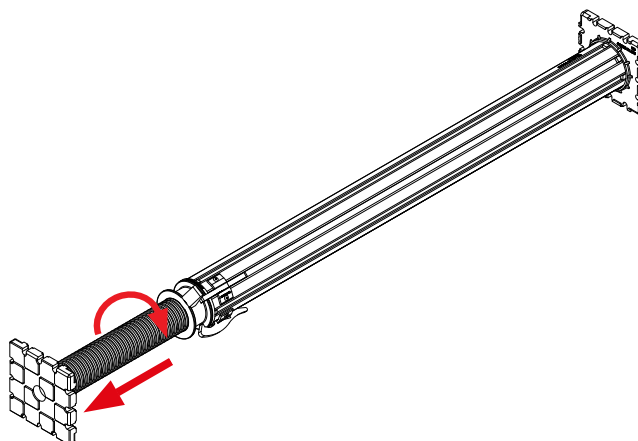

Step 2 Attach the TOPMAX GASS Multi Adapter (code:606993) to the GASS Legs using 4no. Ring Bolt Clamp for GASS Leg to GASS Leg (code:718901) per leg.

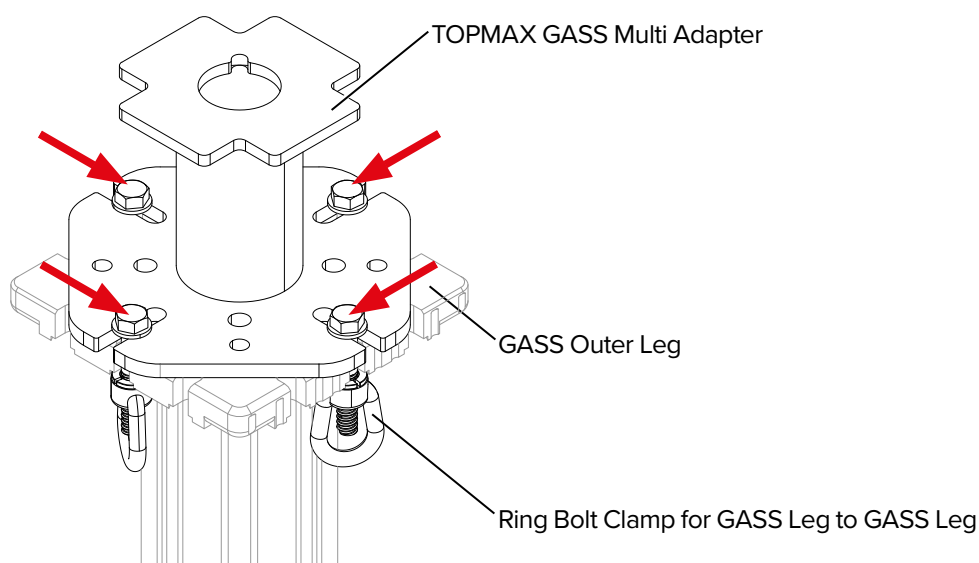

- Step 3** Align the hole of the TOPMAX Folding Head (code:602596) with the connection point on the TOPMAX Floor Table profile.

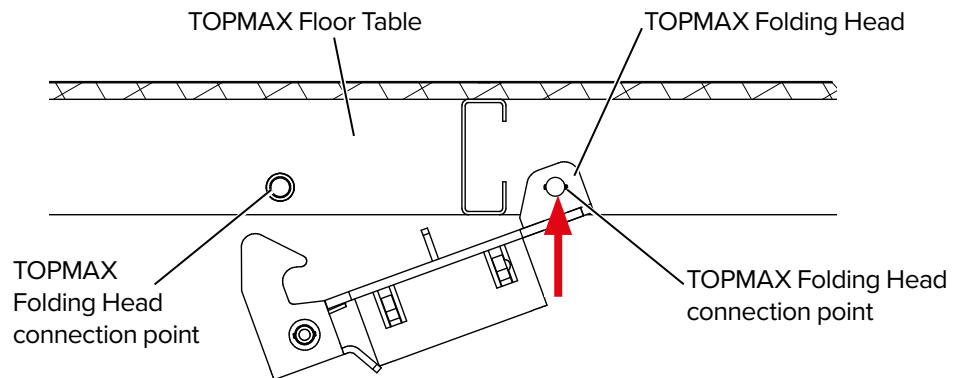

- Step 4** Insert the TOPMAX Locking Pin (code:603067) through the profile to secure the head.

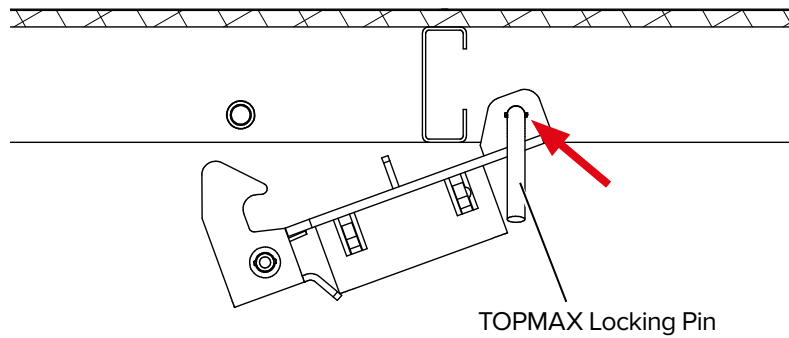

- Step 5** Swivel the head until the claw locks into the connection point on the TOPMAX Floor Table profile.

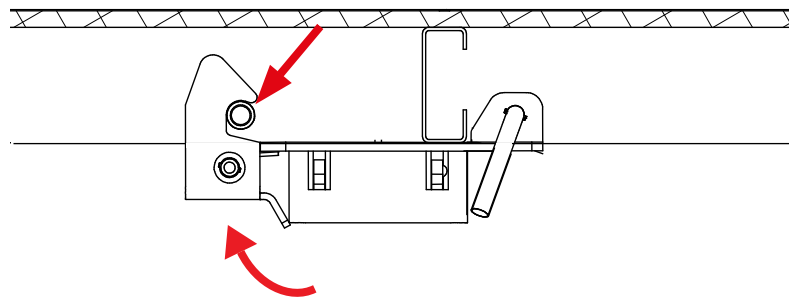

- Step 6** Pull out the double wedge of the folding head. For clarity, in steps 6–8, the table is not show.

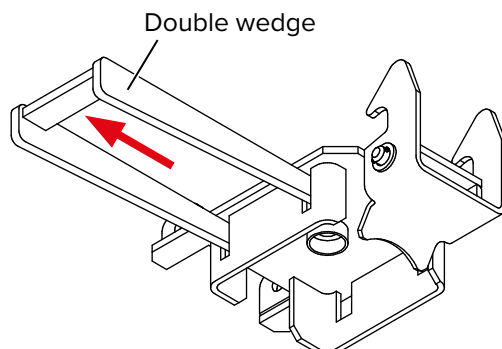

Step 7 Insert the TOPMAX GASS Multi Adapter (code:606993) with the GASS Leg attached into the folding head.

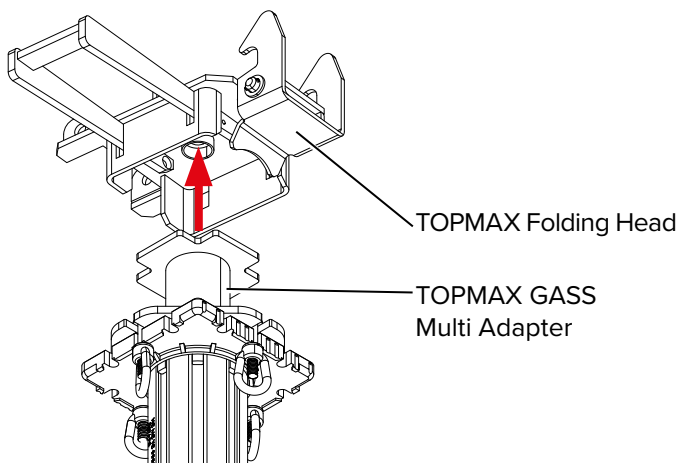

Step 8 Push and strike the double wedge to ensure prop is securely attached.

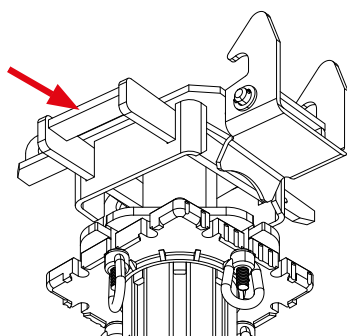

Step 9 Repeat steps 1–8 for the other folding head positions.



CAUTION

Risk of damage to components!

If single GASS Legs are used with the TOPMAX Floor Tables, the legs must not be swung when moving the table and must remain in the vertical position at all times.

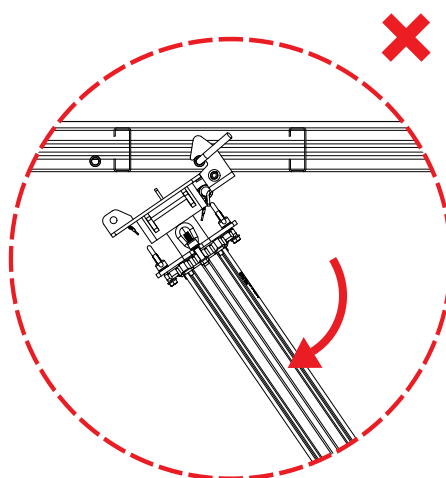

TOPMAX GASS Tower Adapter and GASS Legs



A program to retrofit existing GASS outer legs with the double latch arrangement is underway, during this retrofit period both single and double latch outer legs will be in our stocks. Both options are interchangeable however the separate Safety Latch (code:718907) must be used on all single latch legs when lifting or flying. For more information regarding the GASS system, please refer to the GASS User Guide.

Step 1 Build the GASS frame to the required height.

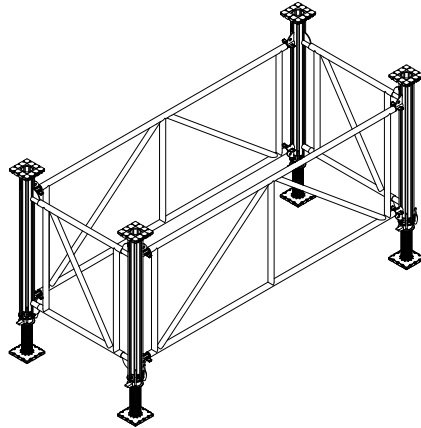

Step 2 Attach the TOPMAX GASS Tower Adapter (code:606994) to each GASS Legs using 4no. Ring Bolt Clamp for GASS Leg to GASS Leg (code:718901) per leg.

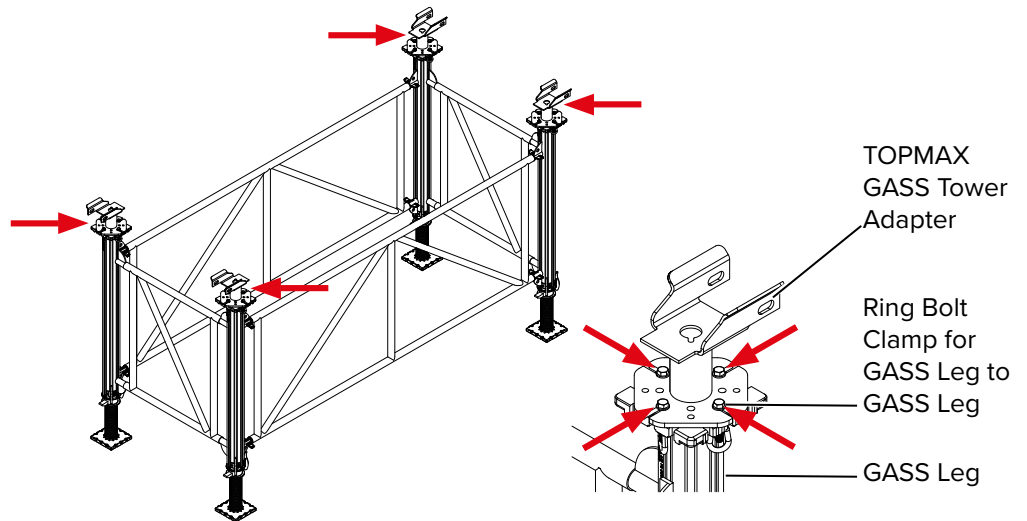

Note the different orientation of the TOPMAX GASS Tower Adapters (code:606994) at each end.

Step 3 Attach 4no. TOPMAX Crane Suspension (code:603050) to a TOPMAX Floor Table. See page 145 for information regarding the TOPMAX Crane Suspension (code:603050).

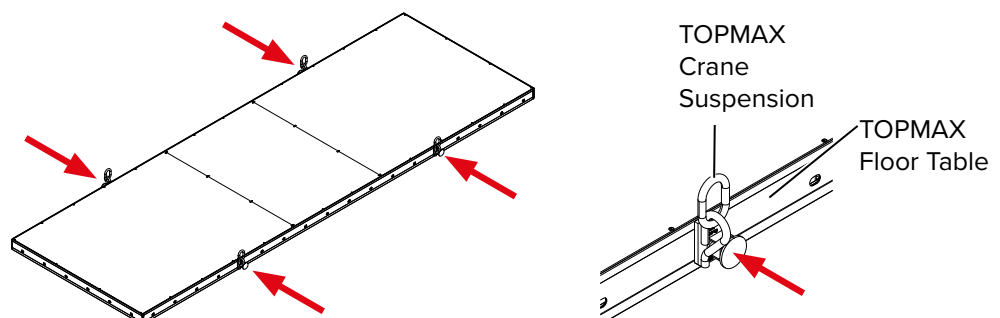

Step 4 Attach slings to the TOPMAX Crane Suspension (code:603050) and lift the TOPMAX Floor Table.

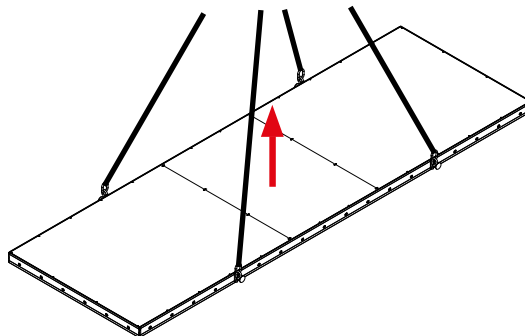

Step 5 Position the TOPMAX Floor Table on top of the GASS frame and lower until the table is supported by the TOPMAX GASS Tower Adapters (code:606994). Align the holes in the TOPMAX main profile with the slot holes of the TOPMAX GASS Tower Adapters.

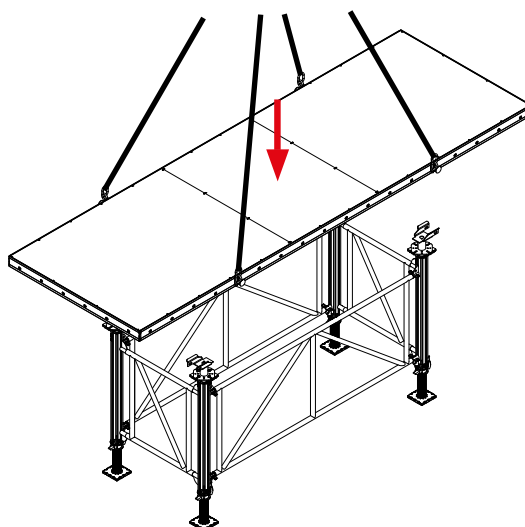

WARNING

Risk of damage, collapse and/or serious injury!

Ensure that the weight of the TOPMAX Floor Table is evenly distributed on all props.

Step 6 Secure the table by inserting a TOPMAX Locking Pin (code:603067) through the slot hole of each of the 4no. TOPMAX GASS Tower Adapters (code:606994).

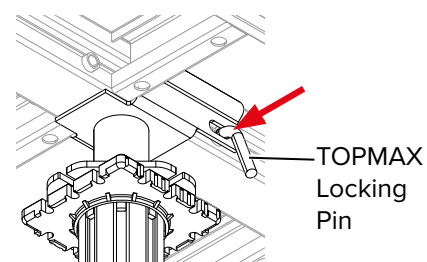
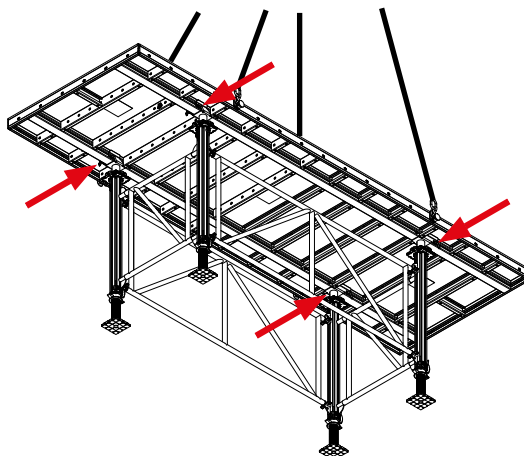

- Step 7** After checking that the table is stable, remove the crane slings and the TOPMAX Crane Suspension (code:603050).

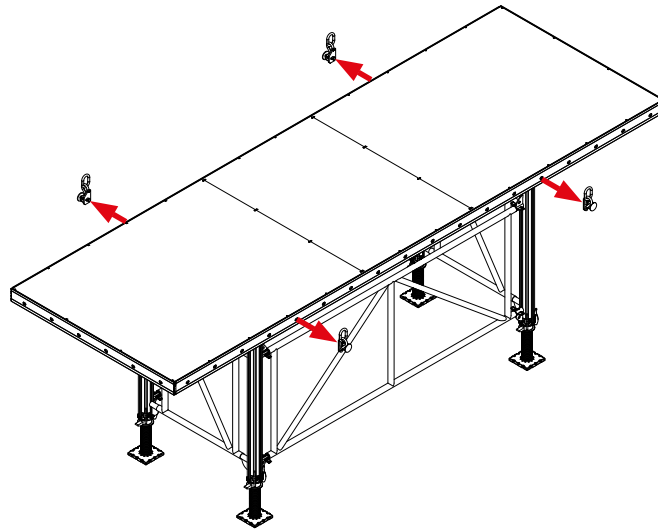

5.3 Extension Frames

The TOPMAX Extension Frame (code:603479) is used at job sites with high slab heights up to 7.62 m when the extension length of the EUROPLUSnew props is not sufficient.

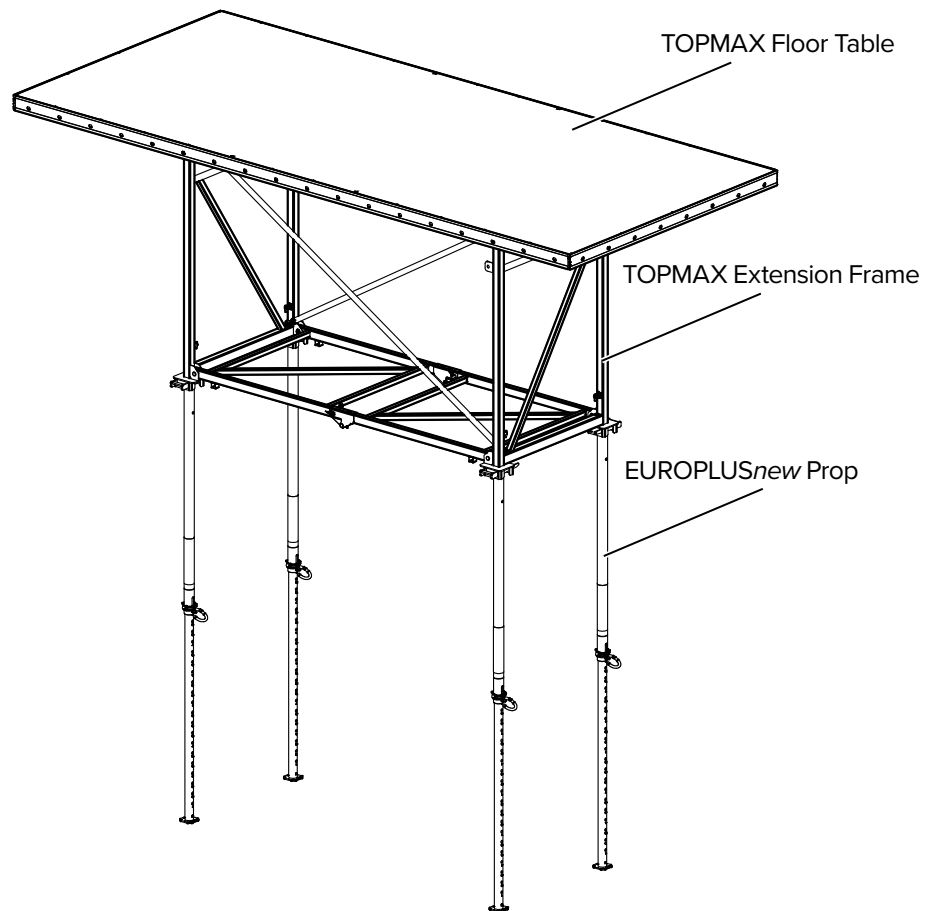

WARNING

Risk of damage, collapse and/or serious injury!

Two operatives are required to assemble the TOPMAX Extension Frame (code:603479) to prevent the vertical frames from unintended dropping.

Step 1 To unfold the TOPMAX Extension Frame (code:603479) pull out the spring pin 4 and the waler bolt D20.

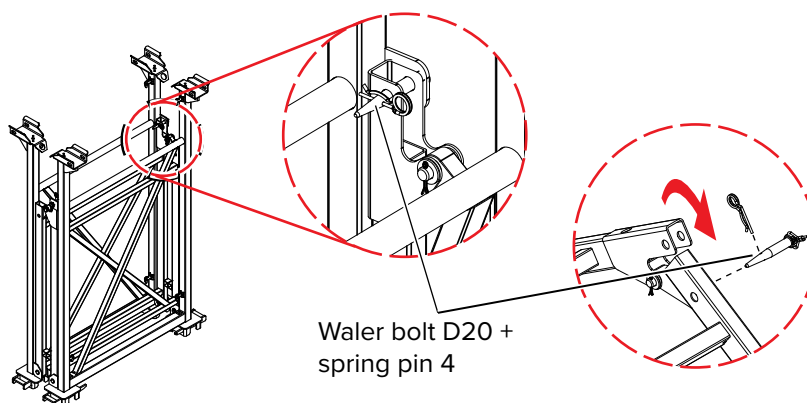

Step 2 Unfold the frame.

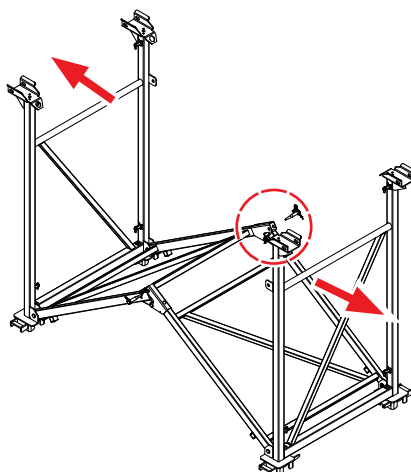

Step 3 Insert the waler bolt D20 and secure with the spring pin 4.

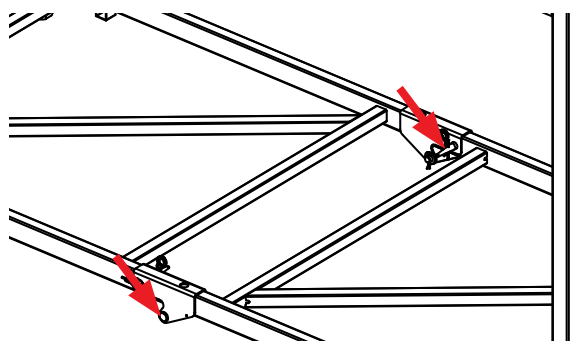

- Step 4** Brace using 2no. Diagonals 203 (code:110167) which have to be ordered separately. Secure the diagonal by hooking into the lower cross beam of the extension frame and secured to the anti-luce fittings at the top of the opposite side.

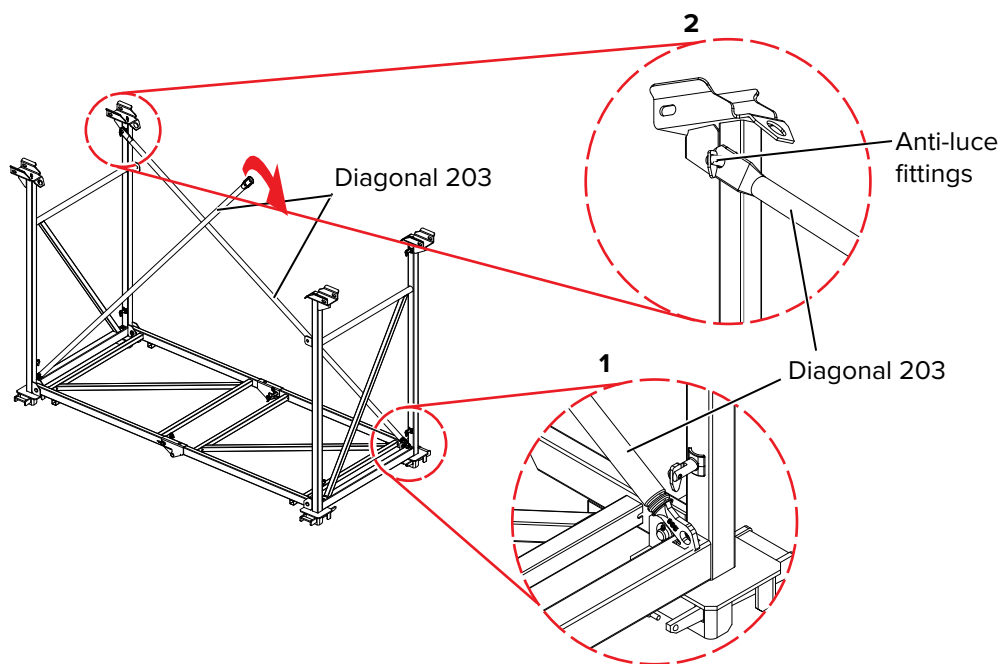

- Step 5** Extend the EUROPLUSnew Props to the required height, see page 29.

- Step 6** Slide out the double wedge at the bottom corner of the frame.

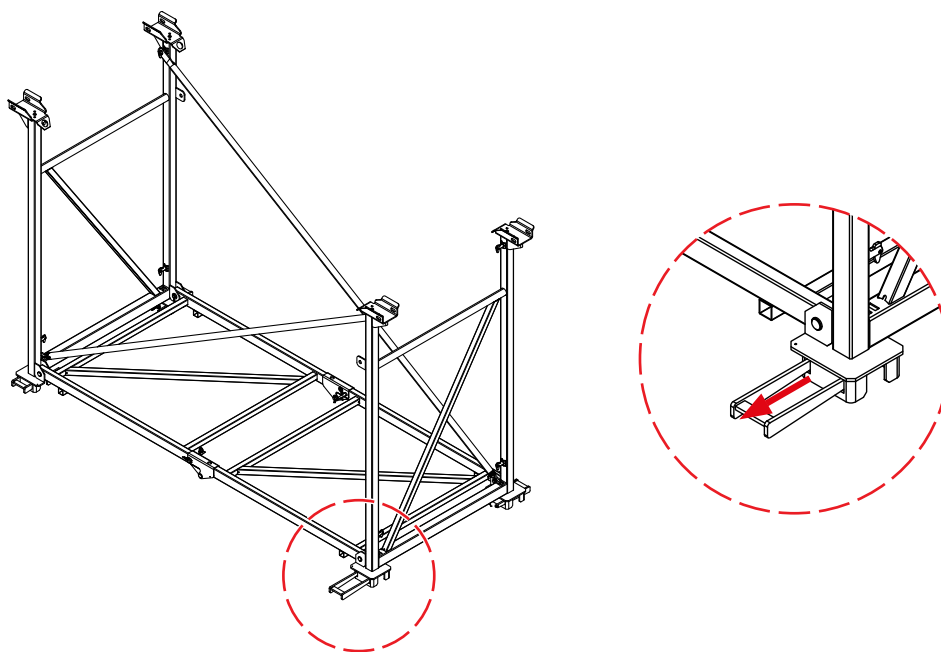

Step 7 Attach the props onto the prop retainer of the frame.

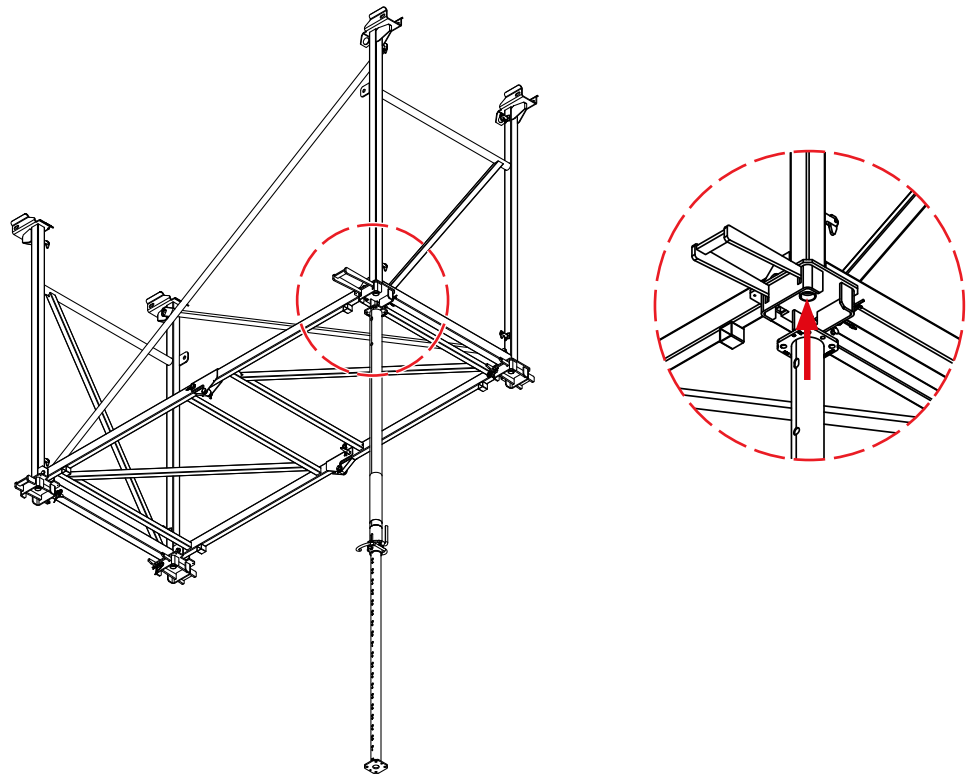

Step 8 Secure the prop by sliding the double wedge in.

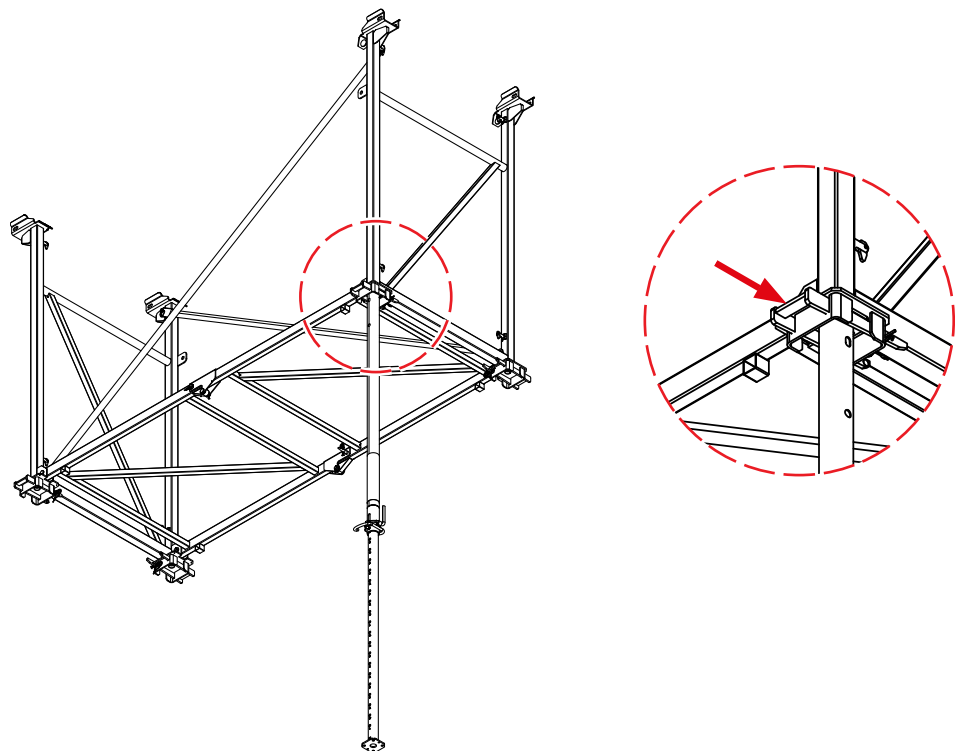

Step 9 Repeat steps 5–8 for the remaining corners.

Step 10 Attach 4no. TOPMAX Crane Suspension (code:603050) to a TOPMAX Floor Table. See page 145 for information regarding the TOPMAX Crane Suspension (code:603050).

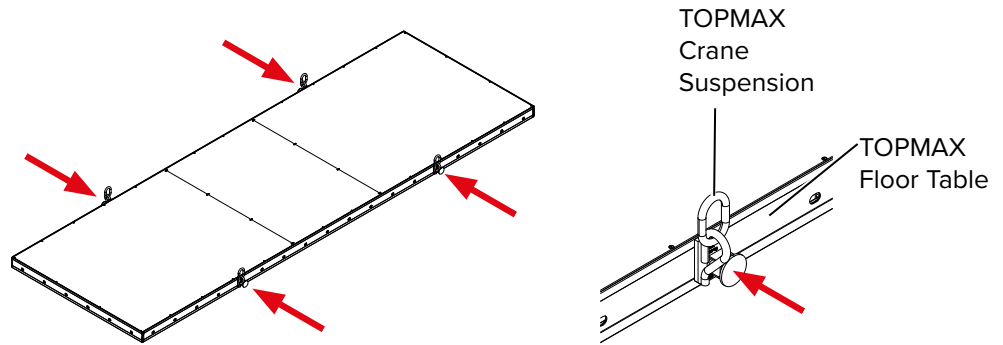

Step 11 Attach slings to the TOPMAX Crane Suspension (code:603050) and lift the TOPMAX Floor Table.

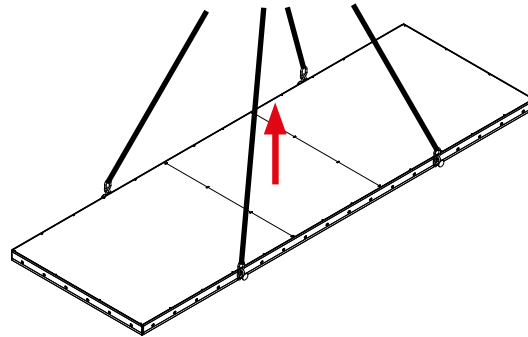

Step 12 Position the TOPMAX Floor Table on top of the frame and strut assembly and lower until the table is supported by the TOPMAX Extension Frame (code:603479). Align the holes in the TOPMAX main profile with the slot holes of the frame.



WARNING

Risk of damage, collapse and/or serious injury!

Ensure that the weight of the TOPMAX Floor Table is evenly distributed.

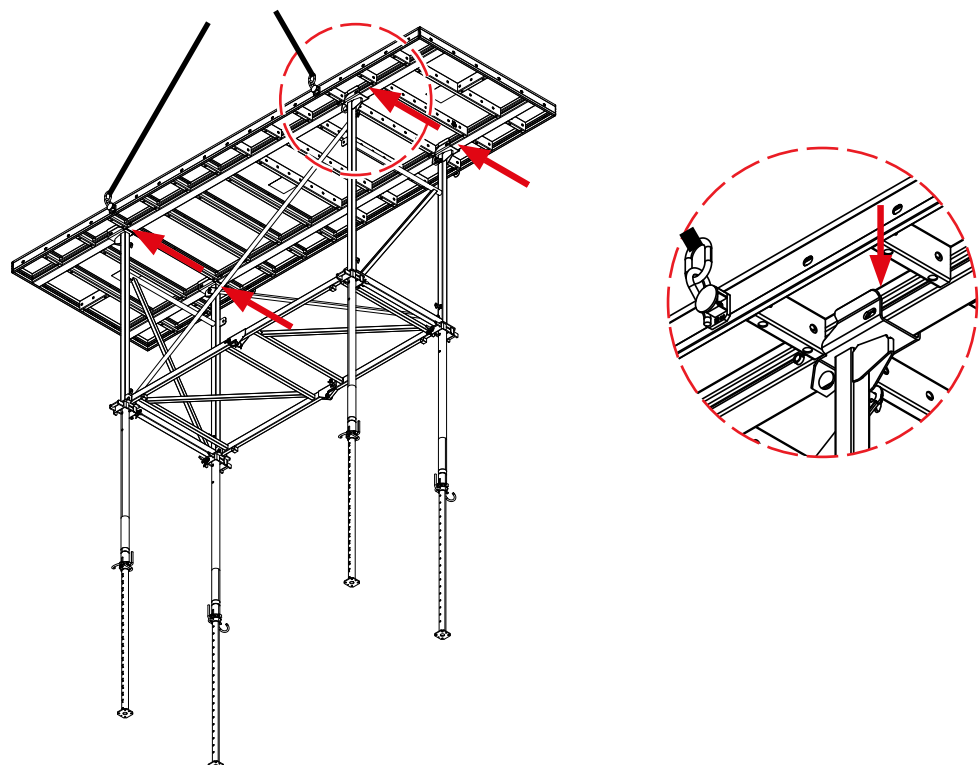

Step 13 Secure the table by inserting the TOPMAX Locking Pin (code:603067) .

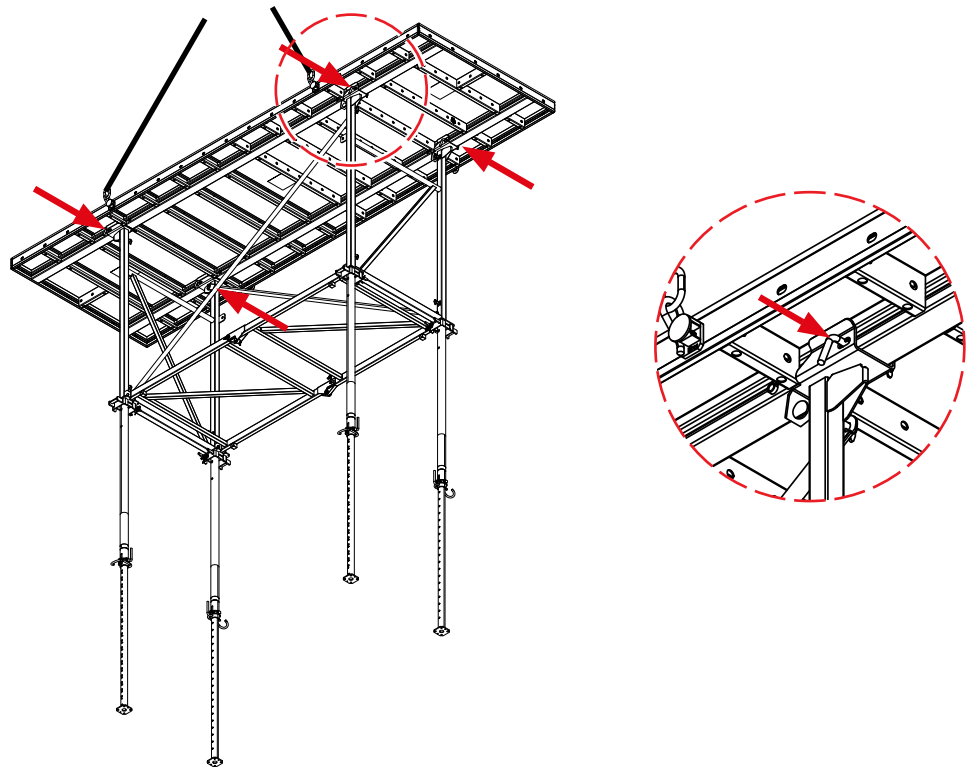

Step 14 Repeat step 13 for the remaining corners.

Step 15 After checking that the table is stable, remove the crane slings and the TOPMAX Crane Suspension (code:603050).

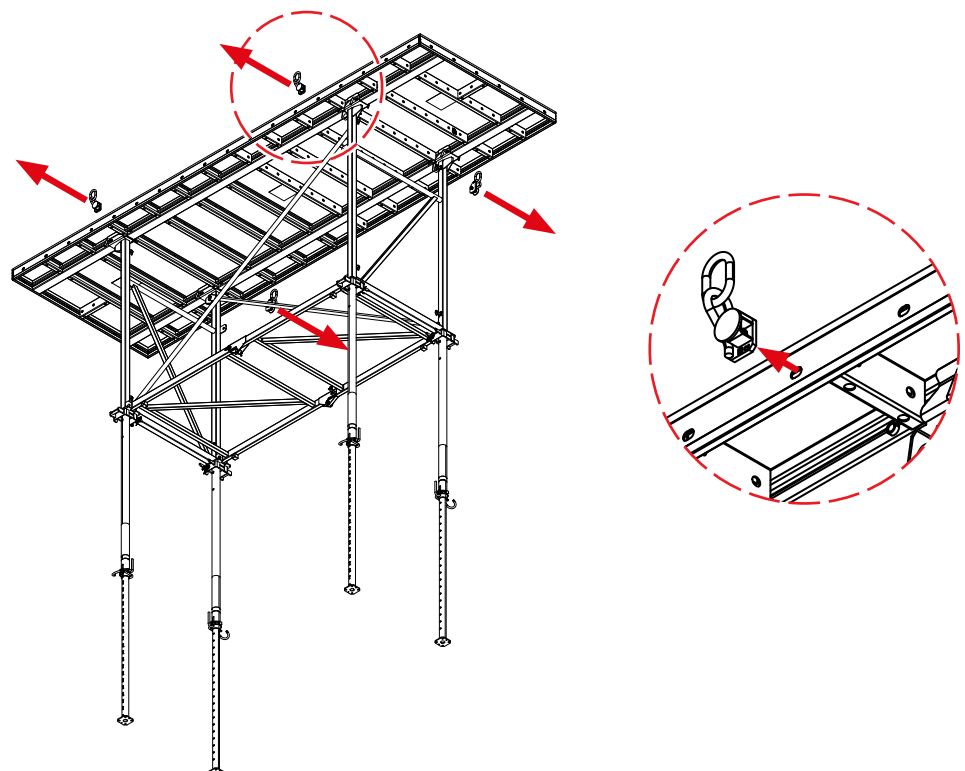

5.4 Extension panels

The TOPMAX Support Girder (code:603390) is a support beam that allows for RASTO/ TAKKO panels to be attached to TOPMAX Floor Tables as an extension or as propped infill panels.

For the use of RASTO or TAKKO as infill panels without prop support, see pages 95 and 101.

The TOPMAX Support Girder is attached to the TOPMAX during the assembly of the table on the ground and the whole assembly can be lifted by crane into position. The girder is attached to the TOPMAX Floor Table and the cantilevered arm has to be adjusted according to the width of the RASTO and TAKKO panels.



The TOPMAX Support Girder (code:603390) must be placed as per the design scheme supplied.



WARNING

Risk of damage, collapse and/or serious injury!

TOPMAX Floor Tables with extension panels can only be moved using the TOPMAX Lifting Fork (code:603074) or the Multi Mover (code:607150). When moving or lifting tables with extension panels, an additional calculation and approval is required.

Unsupported assembly

Step 1 Remove the safety clips and pins and keep them for later use.

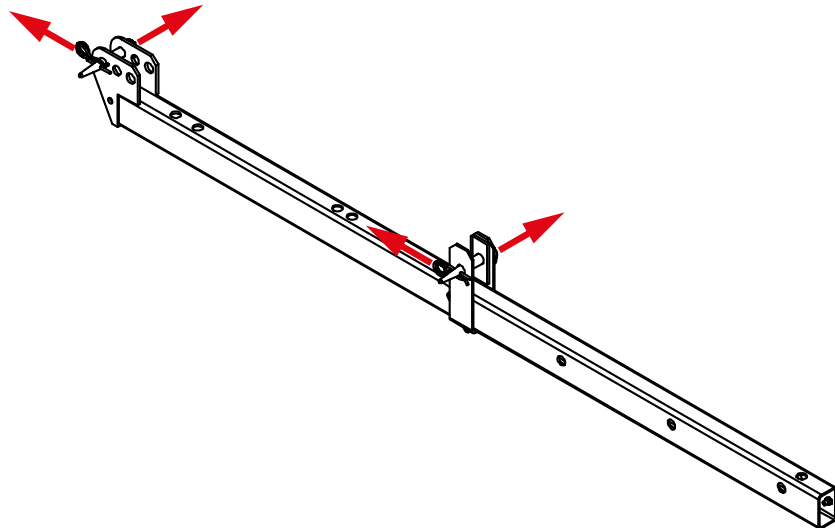

Step 2 Position the TOPMAX Support Girder (code:603390) as per the design scheme supplied. Align the hole of the girder with the hole position of the table.

Step 3 Secure the girder using 2no. Waler Bolt D20 (code:420000) and 2no. Spring Pin 4 (code:173776). that were removed earlier on step 1.

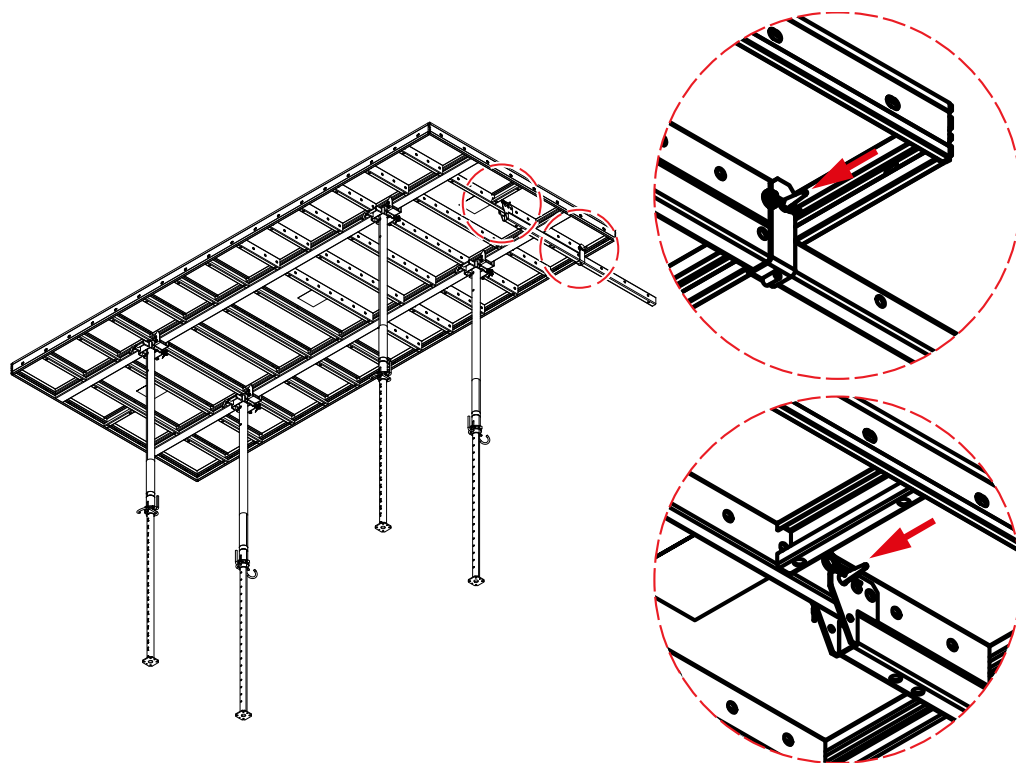

The hole position to be used on the TOPMAX Floor Table will vary depending on the job requirements. Refer to the scheme design supplied.

Step 4 Repeat steps 1–5 for the other girder positions (see notes regarding placement of the girder shown above).

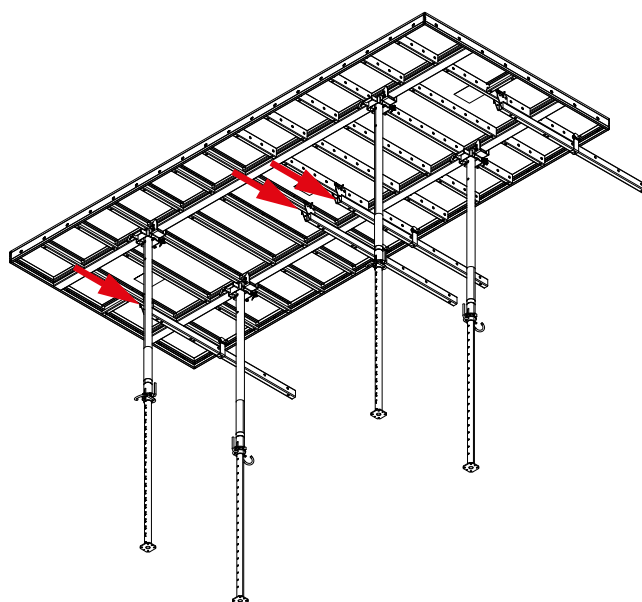

WARNING

Risk of damage, collapse and/or serious injury!

If no support for the extension panels is used, additional measures to prevent overturning are required at this moment before installing the extension (cantilevered) panels.

Supported assembly

If there is a requirement to support the cantilever of the girder, mid way or at the end, continue the assembly as below. If support is not required, skip steps 7–12.

- Step 5** Position the TOPMAX Lockable Head (code:603404) so that the holes of the head align with the correct hole position of the cantilevered arm of the girder.



The position of the TOPMAX Lockable Head (code:603404) will vary depending on the job requirements. Refer to the scheme design supplied.

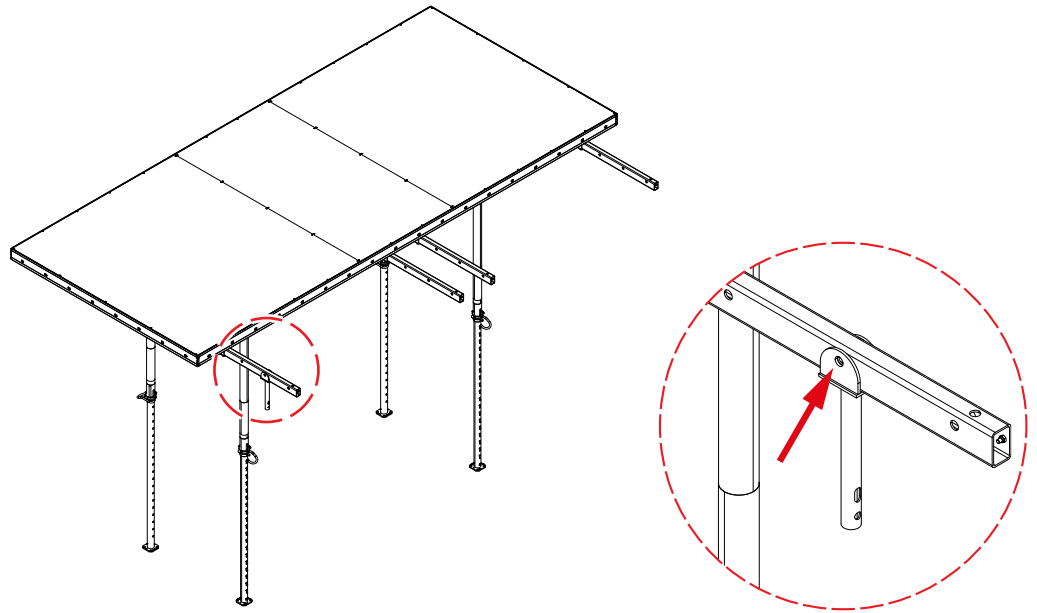

- Step 6** Secure the head using a Waler Bolt D20 (code:420000) and a Spring Pin 4 (code:173776).



The Waler Bolt D20 (code:420000) and the Spring Pin 4 (code:173776) are not included with the TOPMAX Lockable Head (code:603404) and will have to be ordered separately.

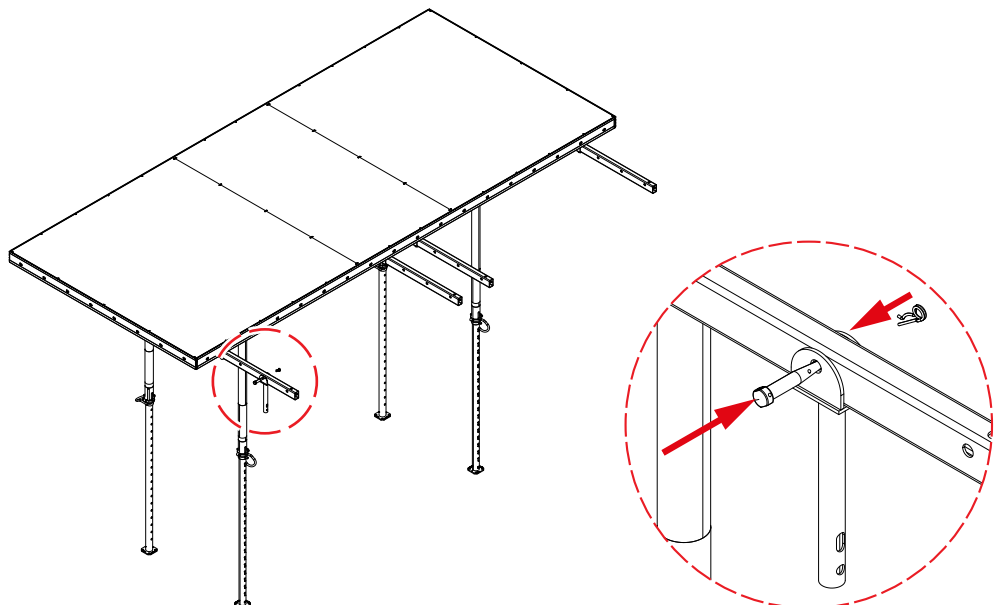

Step 7 Insert the EUROPLUSnew Prop in the TOPMAX Lockable Head (code:603404).



The type of EUROPLUSnew Prop will vary depending on the job requirements. Refer to the scheme design supplied.

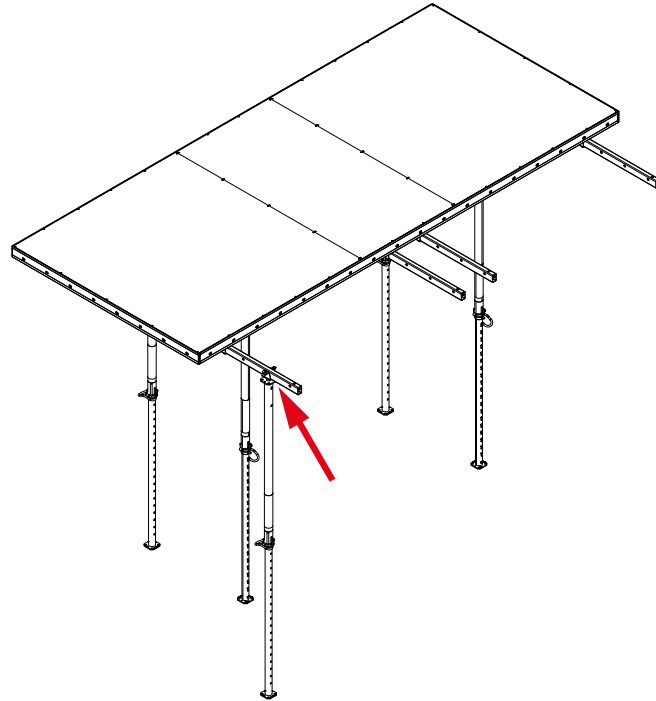

Step 8 Secure the head using a TOPEC Bolt. For the appropriate bolt to be used see page 107.

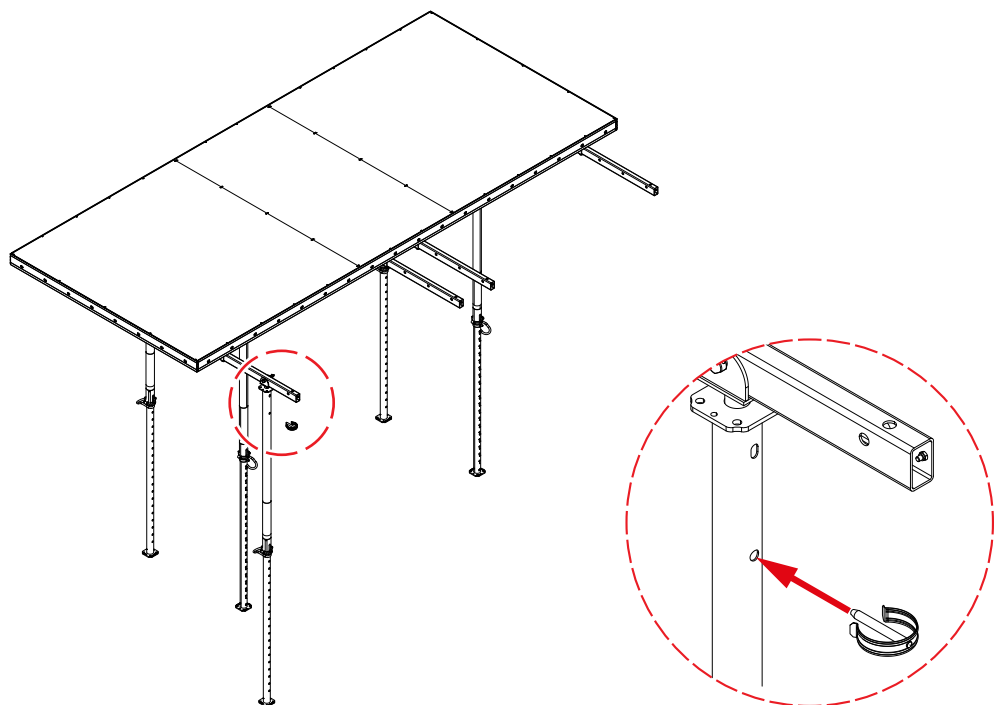

Step 9 Extend the EUROPLUSnew prop to the required height, see page 29.

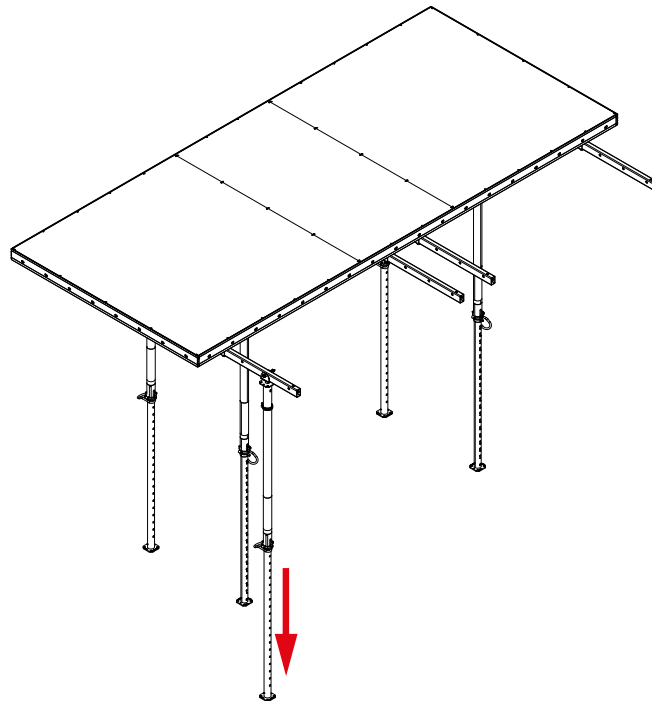

Step 10 Repeat steps 7–11 for the other support positions.

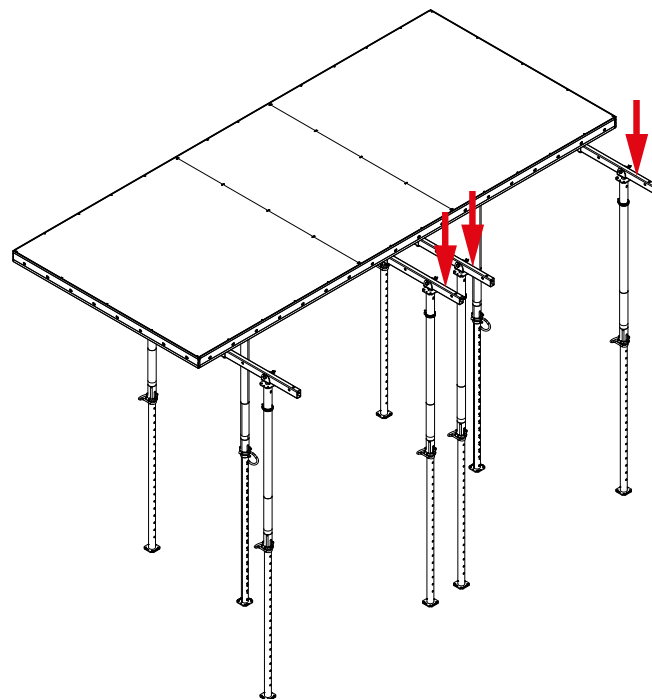

Step 11 Position the RASTO/TAKKO Panel on top of the girders and align with the TOPMAX Floor Table.

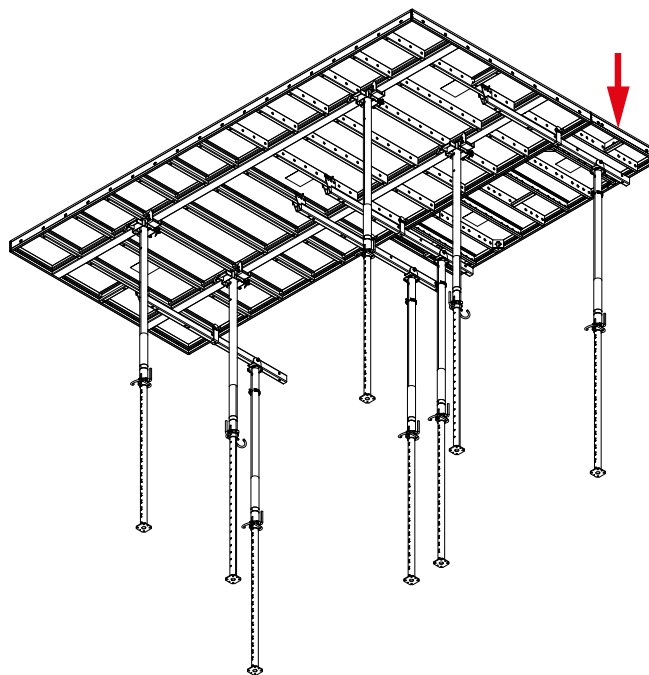

Step 12 Insert the threaded pin of a Centering Tension Bolt (code:479264) into the required hole position on the external profile of the table.

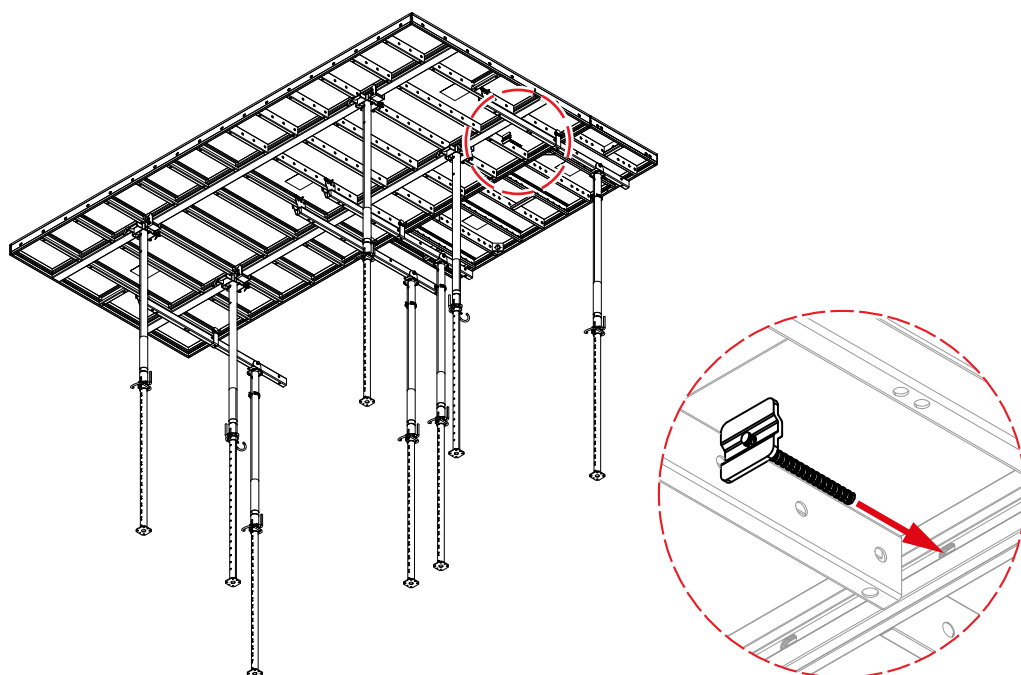

The position and quantity of Centering Tension Bolt (code:479264) and of the Centering Nut (code:469566) used will vary depending on the job requirements. Refer to the scheme design supplied.

Step 13 Secure using a Centering Nut 100 (code:469566) attached from the inside of the external profile of the RASTO/TAKKO panel.

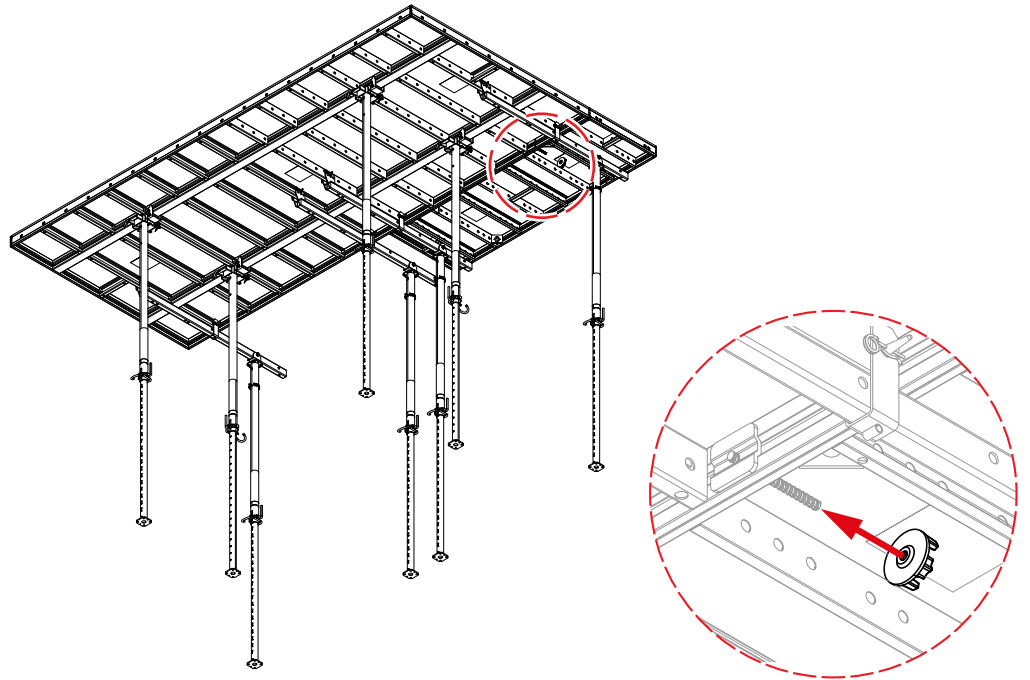

Step 14 Repeat steps 14–15 for the other positions of the nut.

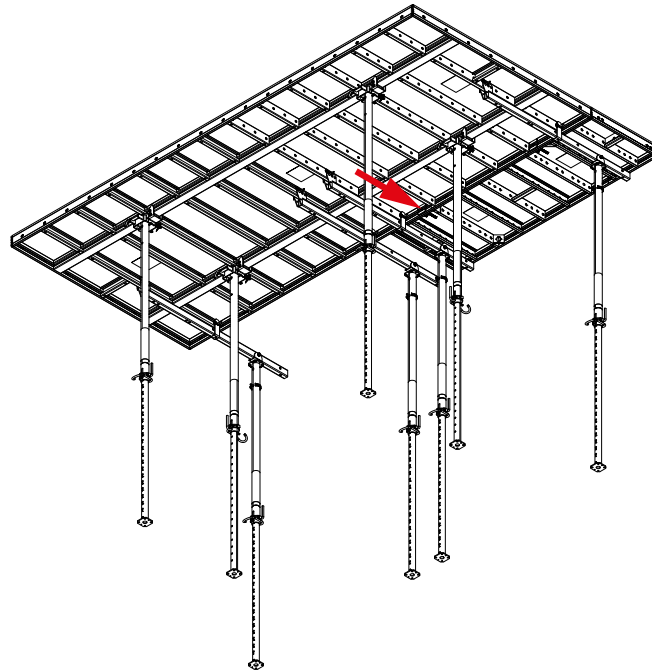

Step 15 Repeat steps 13–16 for the other position of the RASTO/TAKKO panel.

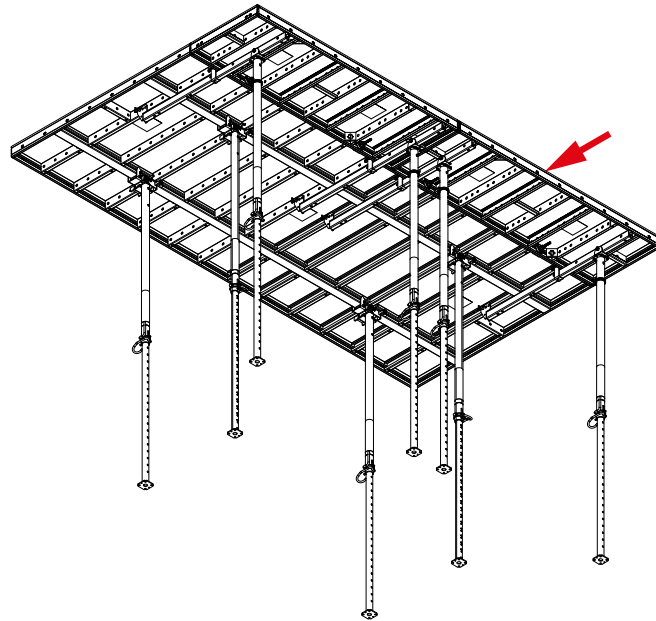

Typical configurations

The following typical configurations are applicable only when using a TOPMAX Floor Table 2.4 x 5.4 m (code:602586). If a TOPMAX Floor Table 1.8 x 5.4 m (code:602585) is to be used, a separate analysis is required.

Case 1 - Cantilevered 0.45 m panels, no support.

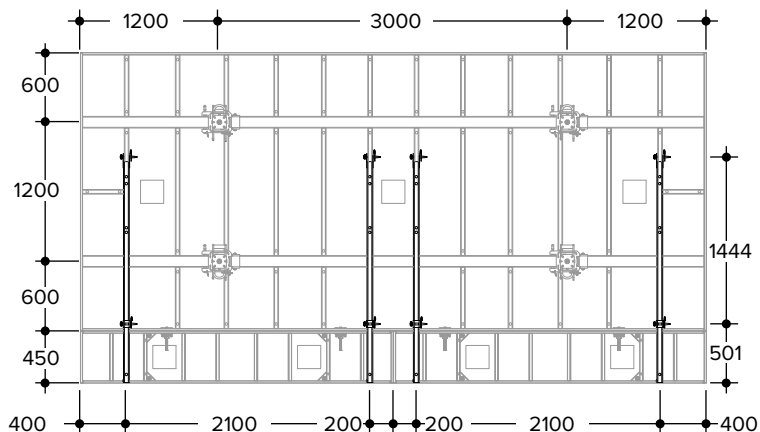
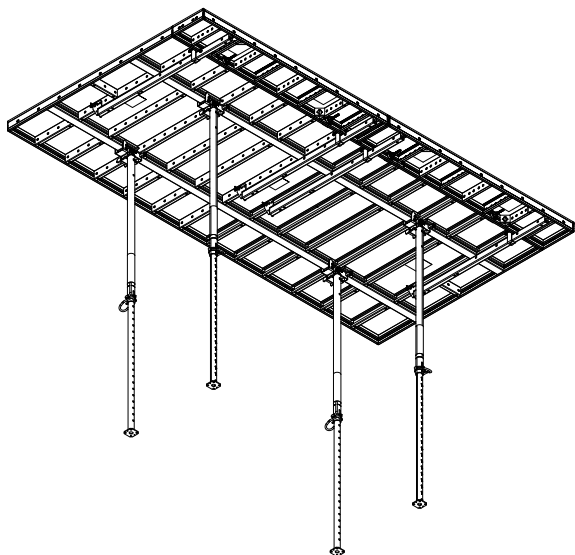

Slab thickness [mm]	Concrete load [kN/m ²]	Support load TOPMAX prop [kN]	Deflection [DIN 18202]
100	4.40	23.10	Line 7
150	5.60	29.70	Line 7
200	6.90	36.30	Line 6
250	8.10	42.90	Line 5
300	9.40	49.60	Line 5
350	10.80	57.30	Line 5



WARNING

Risk of damage, collapse and/or serious injury!

The configuration shown in case 1 is to be used for:

- access only or
- as an infill panel when connected to the next table using Centering Tension Bolts (code:479264) and Centering Nut 100 (code:469566), see page 95.

Case 2 - Cantilevered 0.90 m panels, end support.

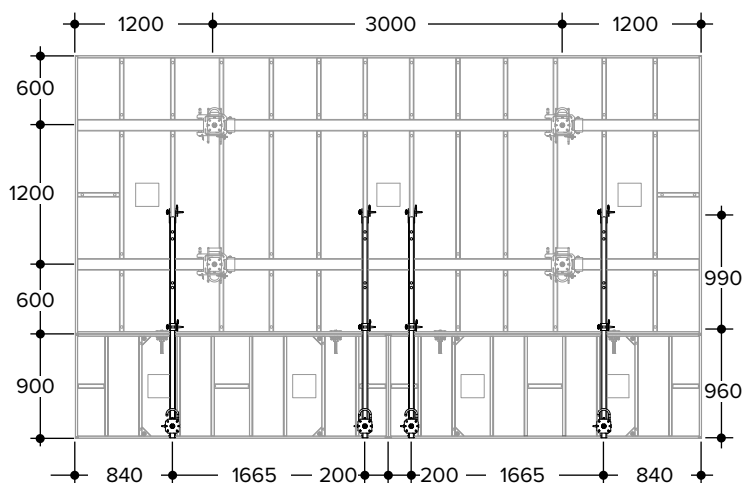
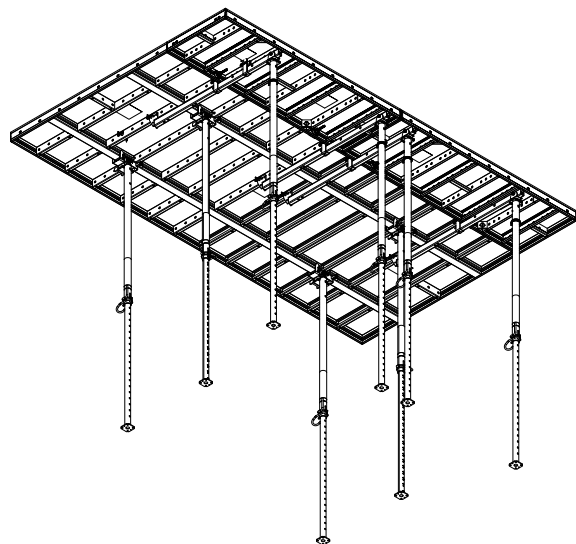

Slab thickness [mm]	Concrete load [kN/m ²]	Support load		Deflection [DIN 18202]
		TOPMAX prop [kN]	RASTO/TAKKO prop [kN]	
100	4.40	19.50	4.20	Line 7
150	5.60	25.00	5.50	Line 7
200	6.90	30.50	6.70	Line 7
250	8.10	36.10	7.90	Line 7
300	9.40	41.70	9.20	Line 6
350	10.80	48.10	10.60	Line 6

Case 3 - Cantilevered 0.90 m panels, middle support.

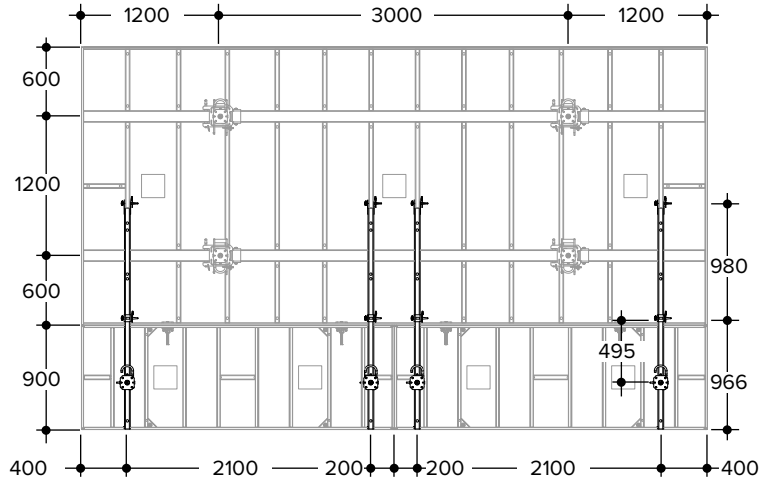
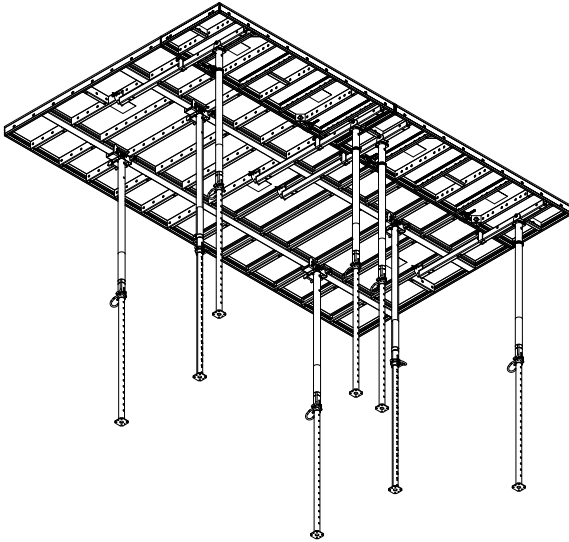

Slab thickness [mm]	Concrete load [kN/m ²]	Support load		Deflection [DIN 18202]
		TOPMAX prop [kN]	RASTO/TAKKO prop [kN]	
100	4.40	14.80	5.90	Line 7
150	5.60	19.10	7.60	Line 6
200	6.90	23.30	9.20	Line 5
250	8.10	27.60	10.90	Line 5

Case 4 - Cantilevered 1.35 m panels, end support.

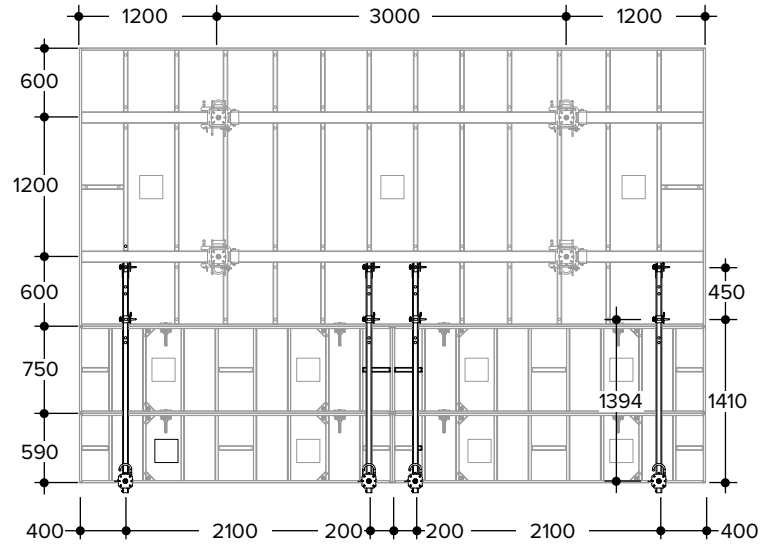
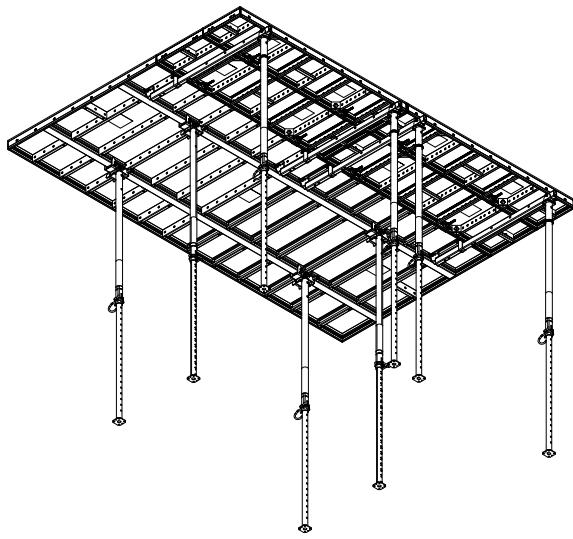

Slab thickness [mm]	Concrete load [kN/m ²]	Support load		Deflection [DIN 18202]
		TOPMAX prop [kN]	RASTO/TAKKO prop [kN]	
100	4.40	30.62	4.50	Line 6
150	5.60	38.90	5.70	Line 5

Case 5 - Cantilevered 1.35 m panels, middle support.

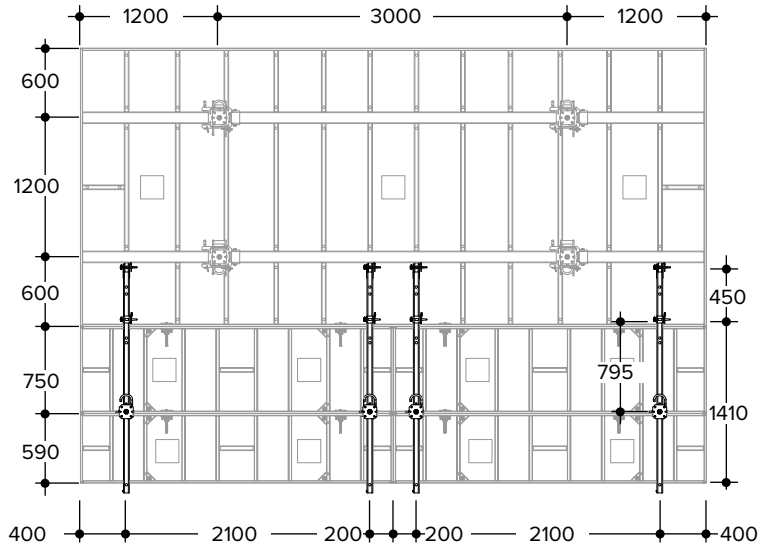
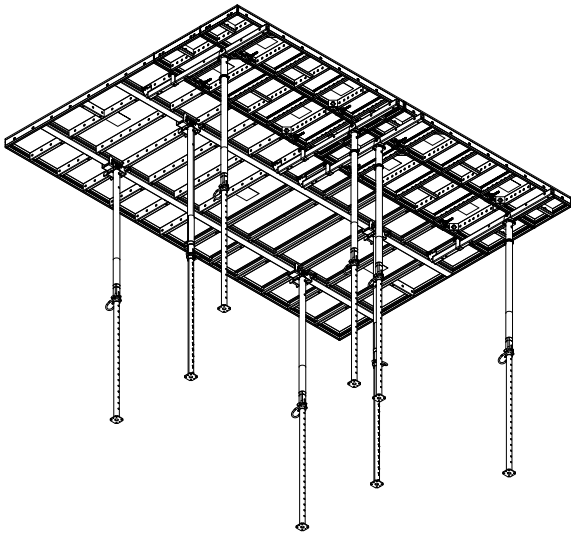

Slab thickness [mm]	Concrete load [kN/m ²]	Support load		Deflection [DIN 18202]
		TOPMAX prop [kN]	RASTO/TAKKO prop [kN]	
100	4.40	19.00	8.30	Line 7
150	5.60	24.40	10.70	Line 7
200	6.90	30.00	13.10	Line 7

5.5 Working platforms

5.5.1 Platforms

TOPMAX Working Platforms can be safely installed whilst the pre-assembled TOPMAX floor tables are on the ground. The whole assembly can then be lifted in one crane lift to the required position on the slab.

The platform is supplied in the folded position.

Step 1 Attach the crane slings to the lifting points on the platform.

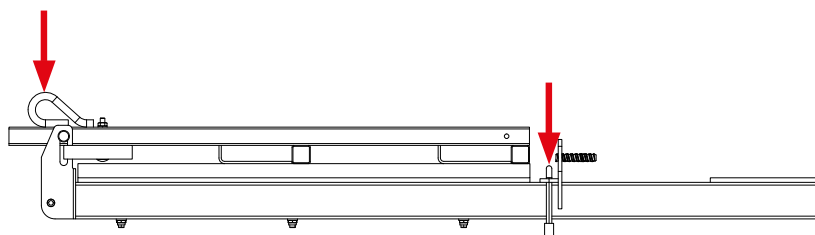

Step 2 Lift the platform into position.

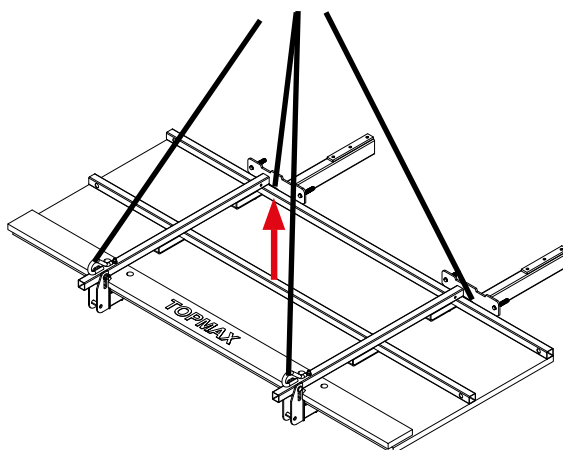

Step 3 Insert the threaded pins of the platform into the required hole positions on the external profile of the table.

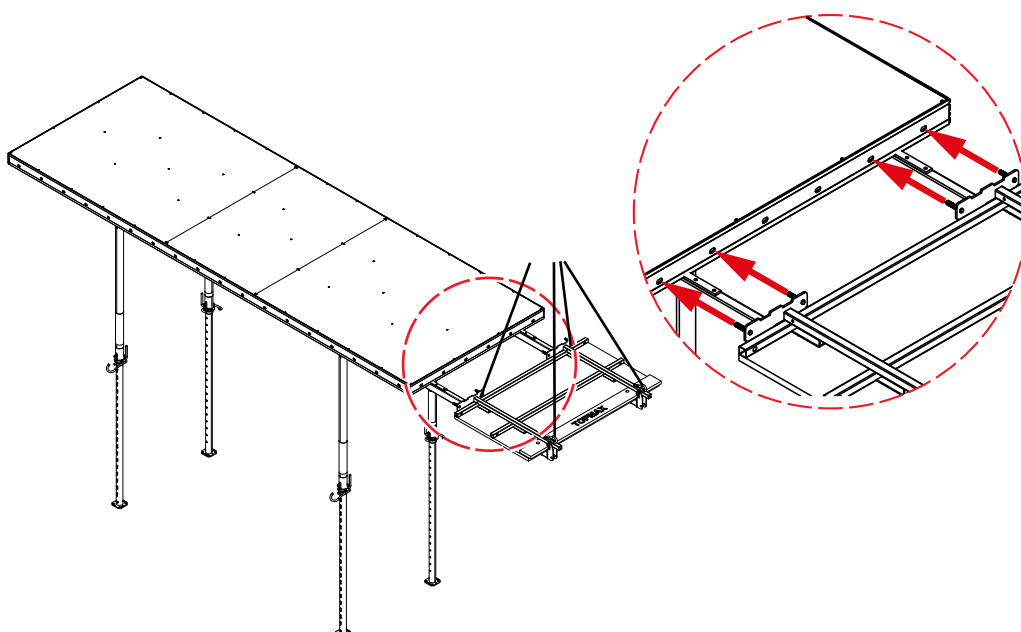

- Step 4** Secure using 4no. Centering Nuts 100 (code:469566) on the inside of the external profile of the table.

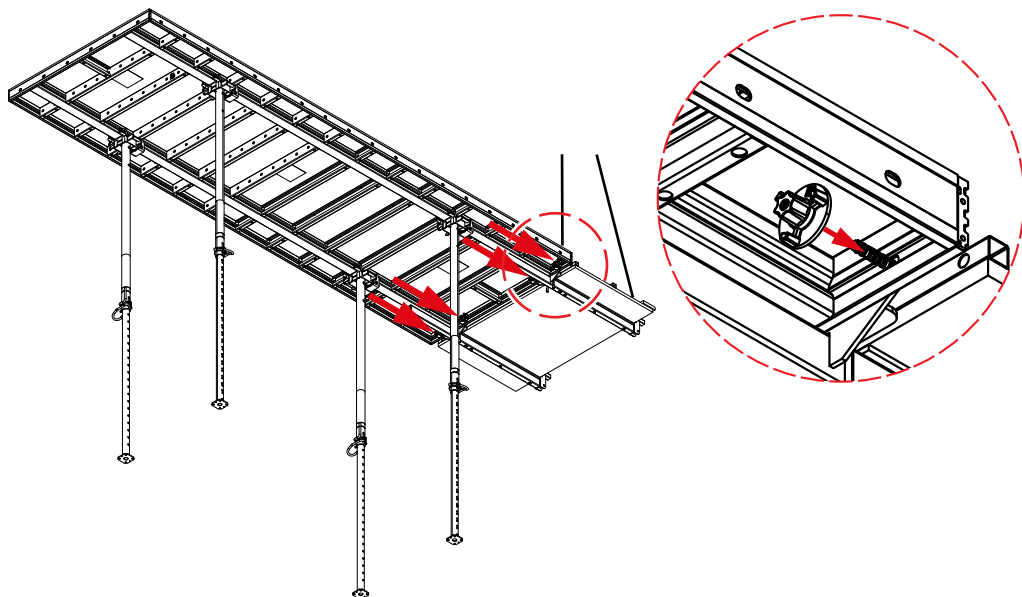

- Step 5** Once the platform is secure, release the crane slings.

- Step 6** Unfold the guardrail posts of the platform until the posts are in the vertical position.



WARNING

Risk of fall!

Always work from a safe position.

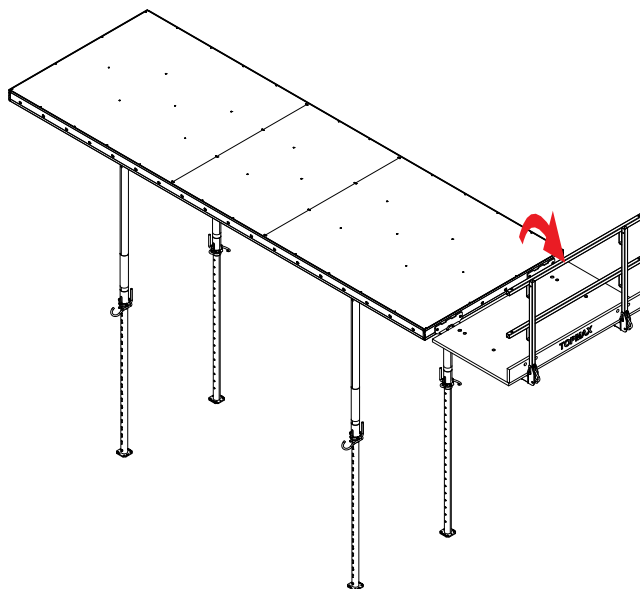

5.6 Edge protection

According to EN 13374 Temporary Edge Protection Systems, the minimum height between the working area and the top of the edge protection should be 1.00 m. This may vary if the top of the slab is to be considered as the working area instead of the top of the formwork panel which will depend on how close the slab end is to the edge of the panel. Although the standard does not go into more detail on how to proceed in this case, it is "good practice" to follow the methods shown below.

Case 1

If the distance between the slab edge and the formwork panel is the same or greater than the slab depth + 600 mm, then the edge protection can be measured from the top of the formwork panel.

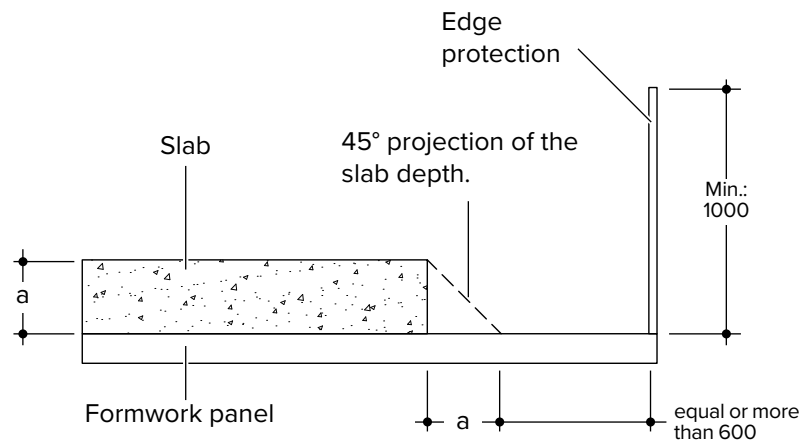

Case 2

If the distance between the slab edge and the formwork panel is less than the slab depth + 600 mm, then the edge protection is measured from the top of the slab.

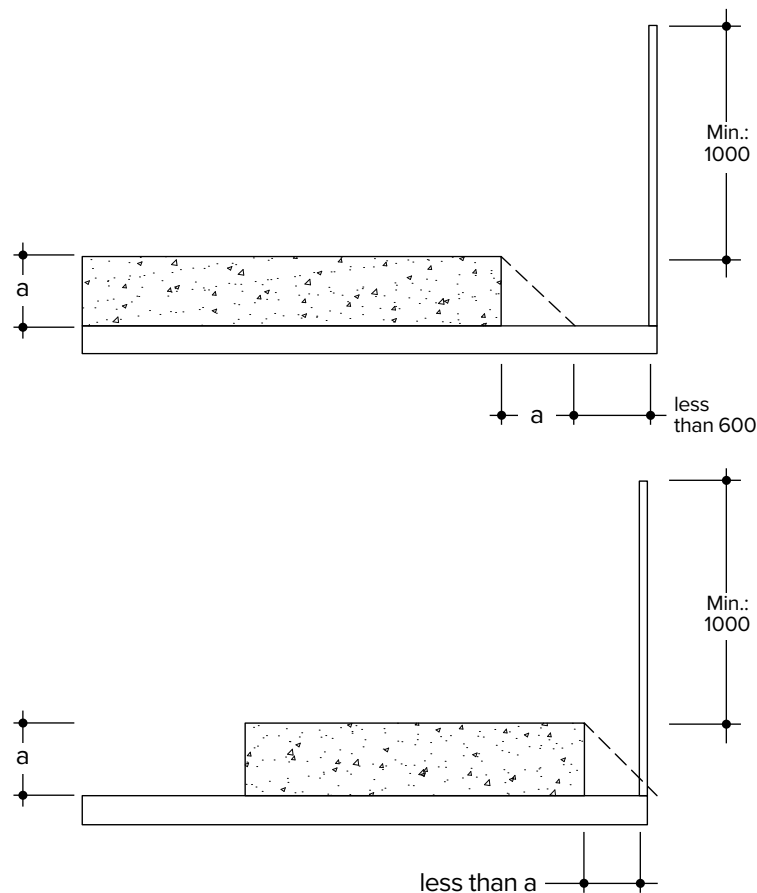

Case 3

If the height of the slab is such that it becomes a fall hazard (check local regulations) then a secondary edge protection is required regardless of the distance between the slab edge and the formwork edge. The height of this secondary edge protection must be 1.00 m measured from the top of the slab.

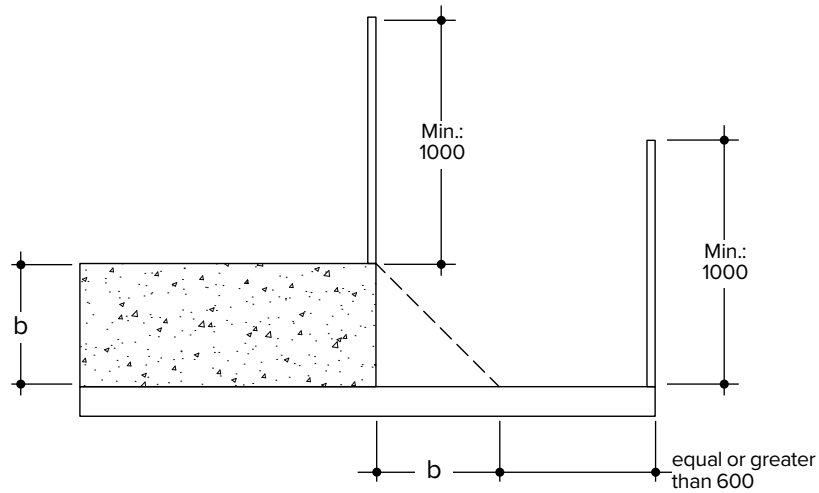

This list of cases illustrates the most common cases used on site but is not exhaustive. Other solutions which comply with the current standard may be used depending on the individual job requirements.



The minimum height of the edge protection may vary from region to region. In Germany for example, the minimum height of the edge protection will change from 1.00 m to 1.10 m if the drop height is more than 12.00 m. Refer to your local regulation for more information.

5.6.1 PROTECTO

PROTECTO Mesh panels without extension

Step 1 Insert the threaded pin of the PROTECTO Post Fastener (code:602123) into the hole position on the external profile of the TOPMAX Floor Table.

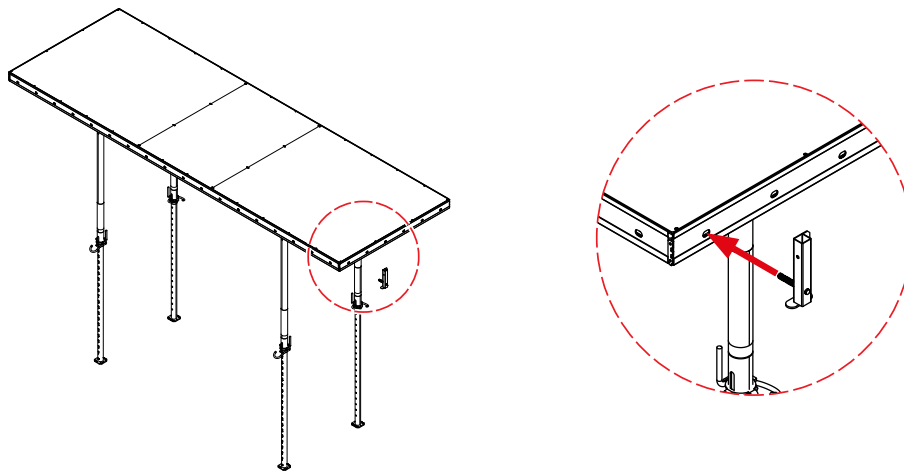

Step 2 Secure the PROTECTO Post Fastener (code:602123) using a Centering Nut 100 (code:469566) on the inside of the external profile of the TOPMAX Floor Table.

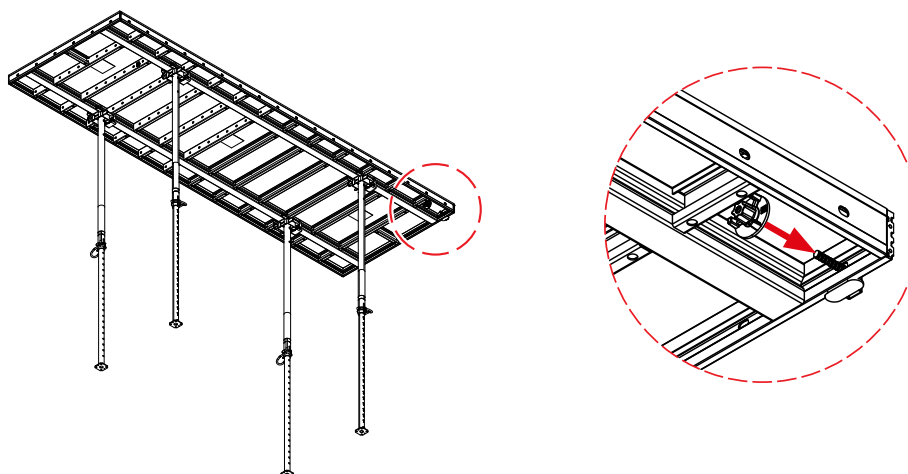

Step 3 Repeat steps 1–2 for the other positions of the post socket.

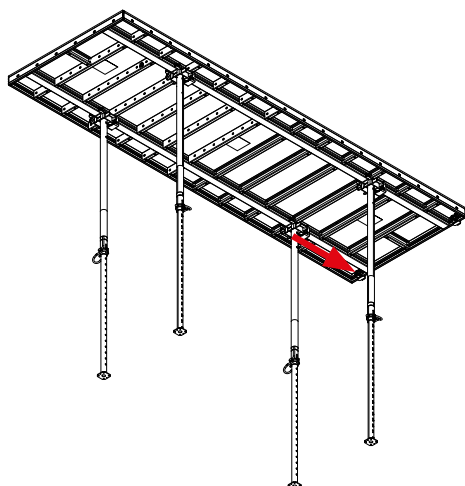

- Step 4** Insert the PROTECTO Railing Post (code:601225) into the PROTECTO Post Fastener (code:602123).

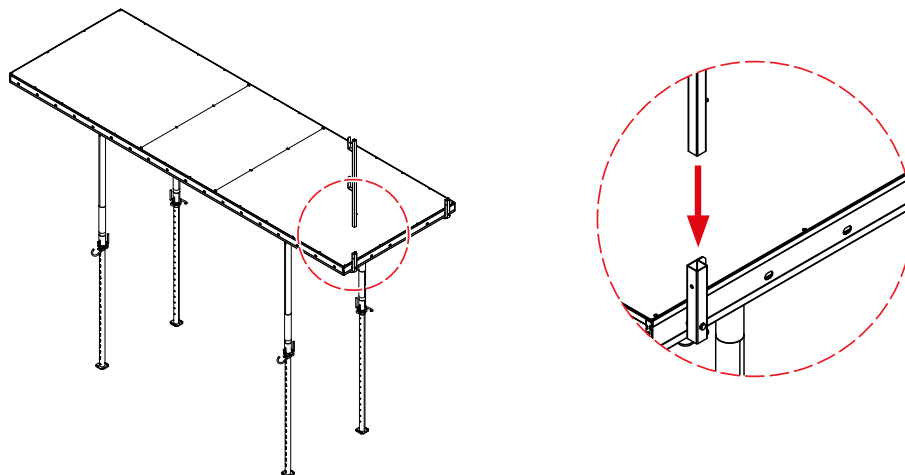

- Step 5** The post is secure when the locking pin is located on the pin hole on the PROTECTO Post Fastener (coded:602123). A "click" sound is produced when the pin springs out of the hole.

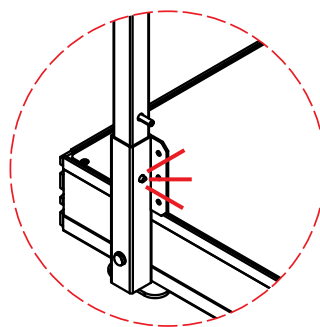

- Step 6** Repeat steps 4–5 for the other positions of the post.

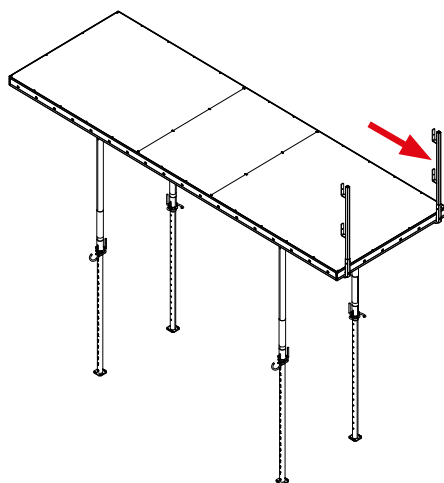

When using PROTECTO Mesh Panels as edge protection, the PROTECTO Railing Posts (code:601225) must not be placed more than 2.40 m apart.

Step 7 Position the PROTECTO Panels on the PROTECTO Railing Posts (code:601225). Ensure that the top of the post protrudes through the mesh at the top of the panel.

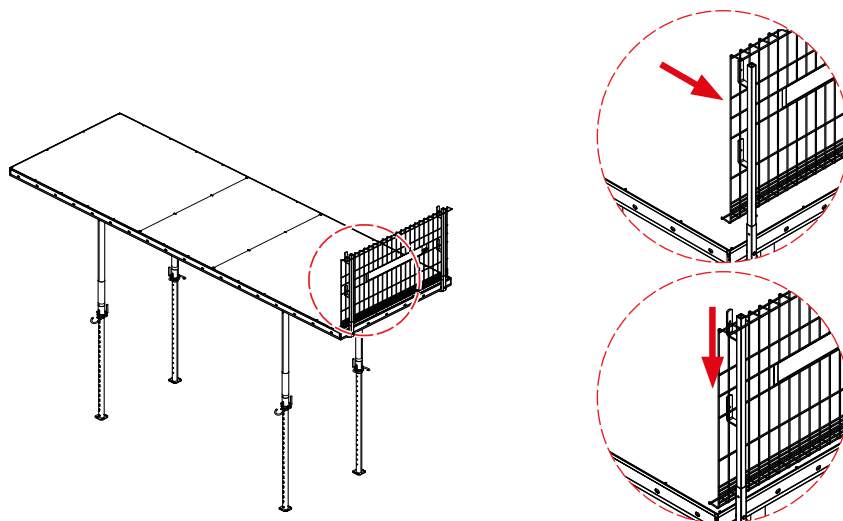

PROTECTO mesh panels with extension

The PROTECTO Post Extension allows for the height of the edge protection to be raised by 260 mm using the PROTECTO Post Extension 26 (code:602111) or by 420 mm using the PROTECTO Post Extension 42 (code:602580).

The typical assembly sequence is the same for both variants.

Step 1 Repeat steps 1–3 shown on page 67.

Step 2 Insert the PROTECTO Post Extension into the PROTECTO Post Fastener (code:602123).

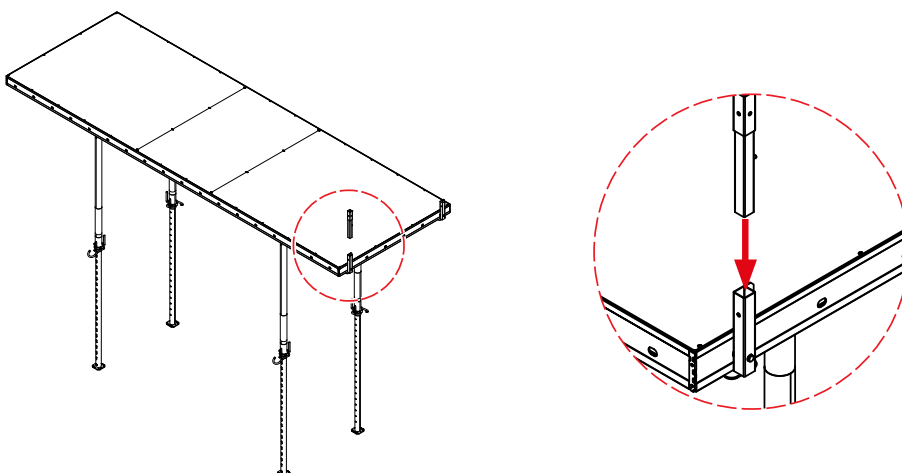

Step 3 The extension is secure when the locking pin is located on the pin hole on the PROTECTO Post Fastener (code:602123). A "click" sound is produced when the pin springs out of the hole.

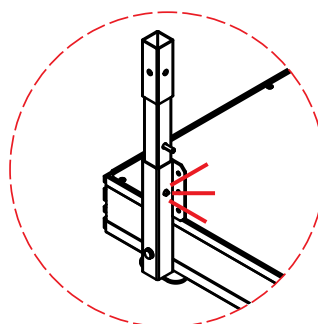

Step 4 Insert the PROTECTO Railing Post (code:601225) into the PROTECTO Post Extension.

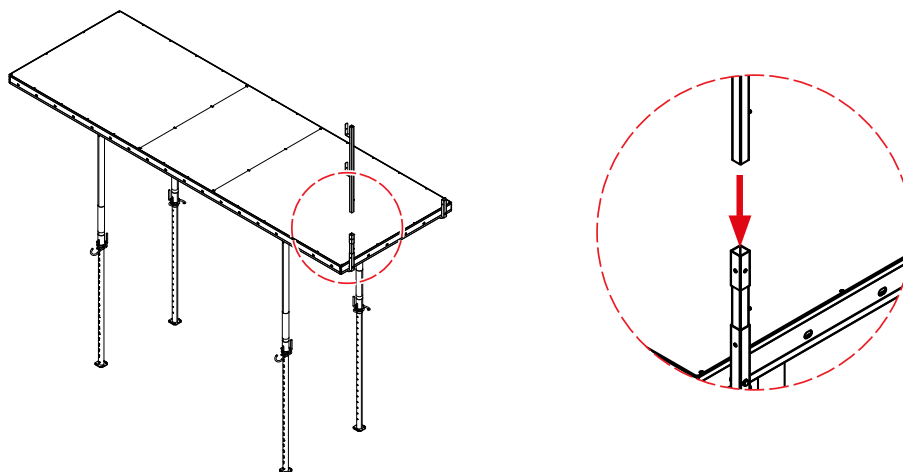

Step 5 The post is secure when the locking pin is located on the pin hole on the PROTECTO Post Extension. A "click" sound is produced when the pin springs out of the hole.

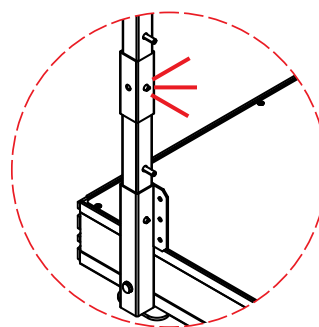

Step 6 Repeat steps 3–5 for the other positions of the post.

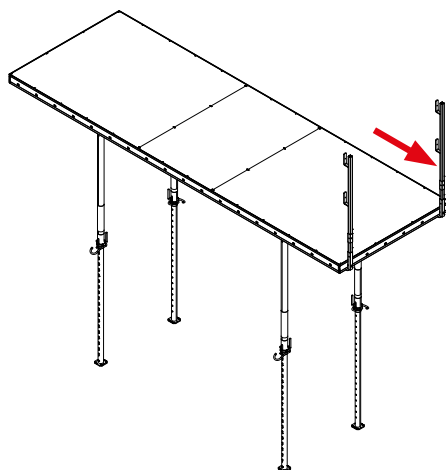

When using PROTECTO Mesh Panels or the Uni Mesh Panels as edge protection, the PROTECTO Railing Posts (code:601225) must not be placed more than 2.40 m apart.

Step 7 Place the toe board in position against the PROTECTO Post Extensions.

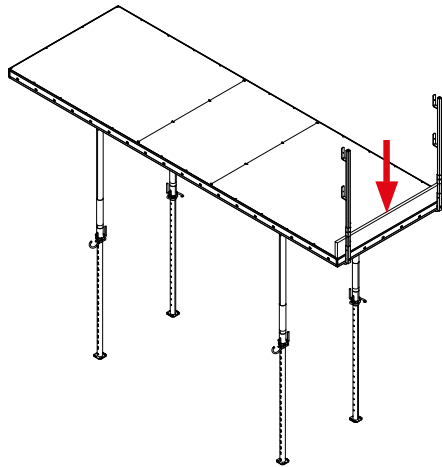

Step 8 Place the PROTECTO Toe Board Retainer (code:601227) on the PROTECTO Post Extension as shown below and rotate the retainer.

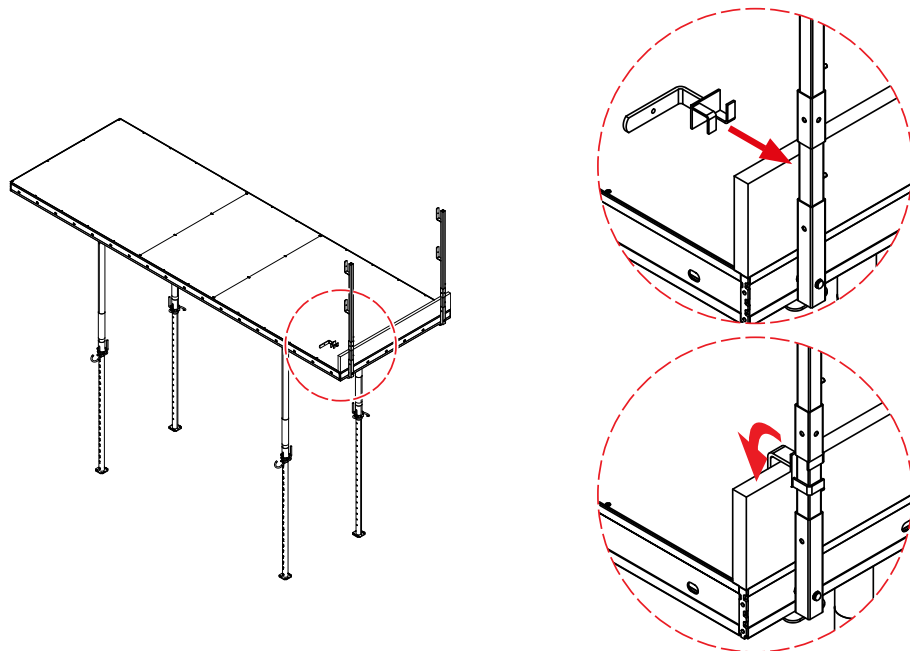

Step 9 Repeat step 8 for the other position of the retainer.

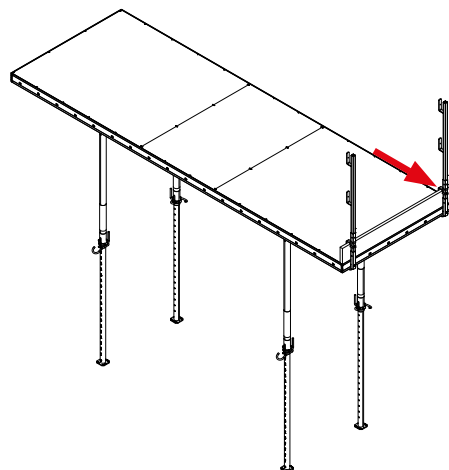

Step 10 Secure the toe board using nails.

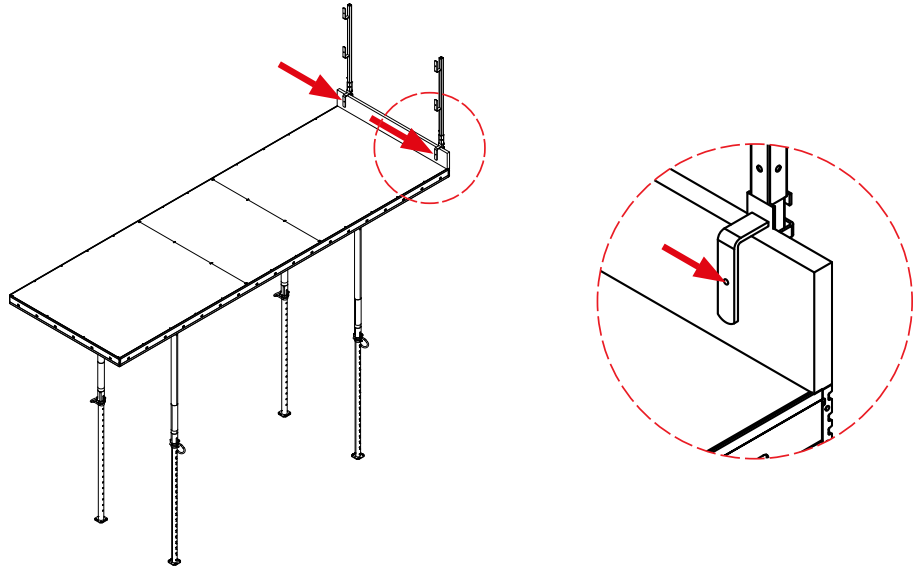

Step 11 Position the PROTECTO Panels on the PROTECTO Railing Posts (code:601225). Ensure that the top of the post protrudes through the mesh at the top of the panel.

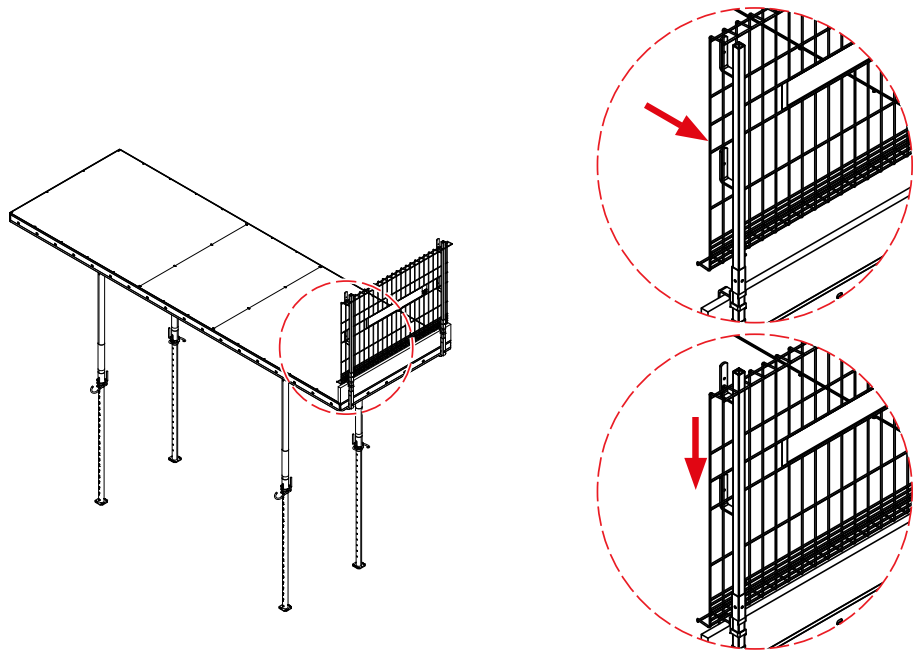

PROTECTO timber boards without extension

Where allowed timber boards can be used to provide edge protection to the TOPMAX Floor Tables.

Step 1 Repeat steps 1–9 shown on page 67.



When using timber boards (30 x 150 mm) as guardrails, the PROTECTO Railing Posts (code:601225) must not be placed more than 2.00 m apart.

Step 2 Position the timber boards on the brackets of the PROTECTO Railing Posts (code:601225).

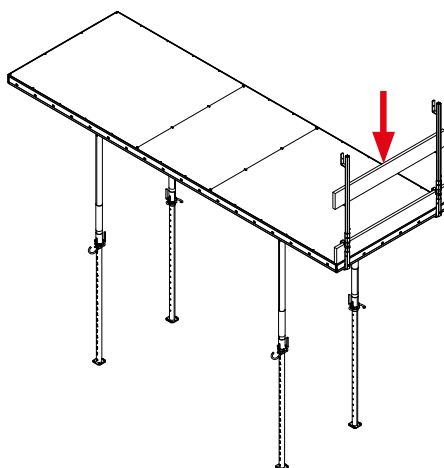

Step 3 Secure using nails.

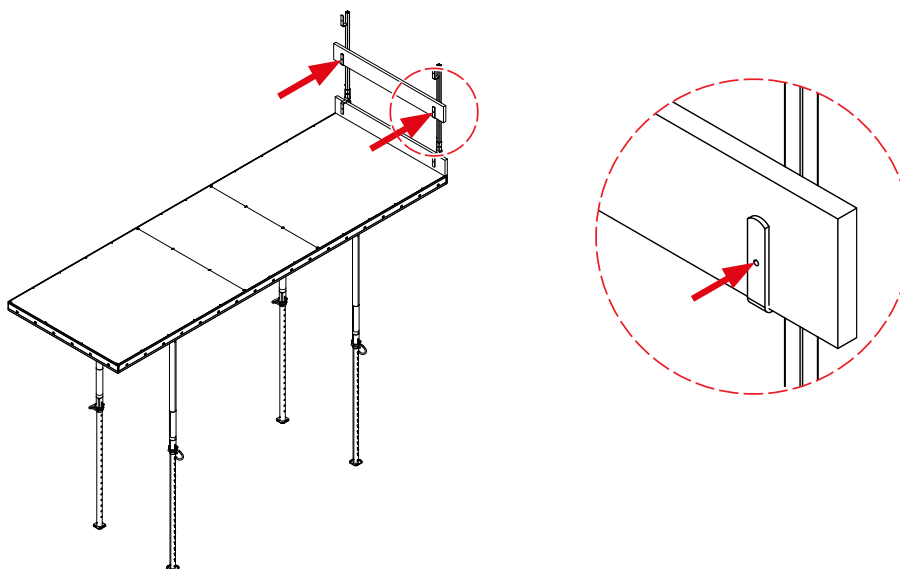

Step 4 Repeat steps 2–3 for the other board position.

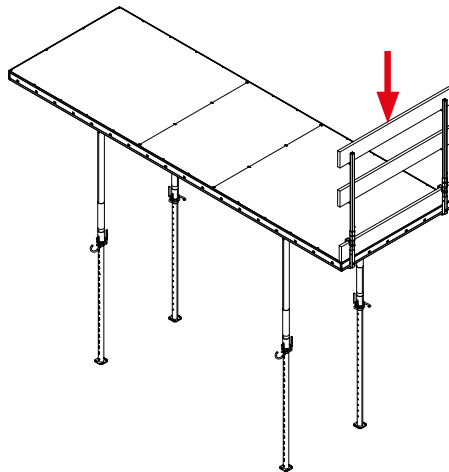

5.6.2 Uni Mesh Panel

Step 1 Repeat steps 1–6 shown on page 67.

Step 2 Position the panel on the brackets of the PROTECTO Railing Posts (code:601225). Ensure the post brackets capture the mesh.

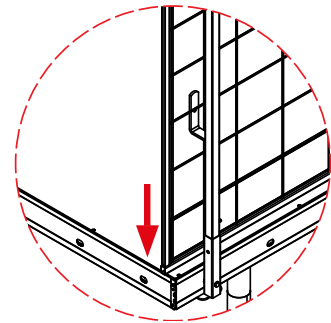
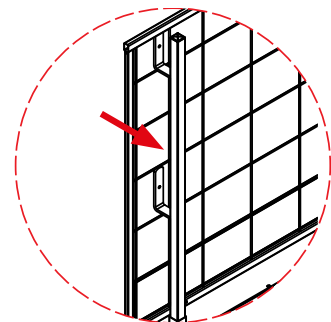
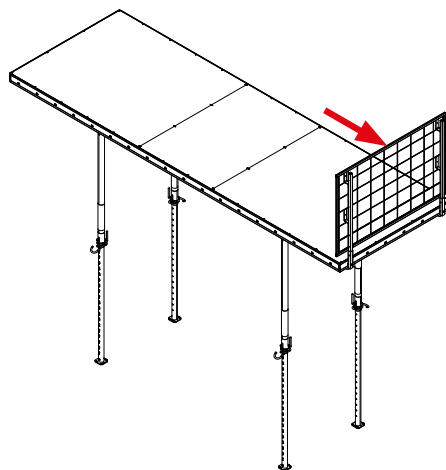

5.6.3 EXTRAGUARD

Step 1 Insert the threaded pin of the TOPMAX EXTRAGUARD Socket Base (code:617605) to the required hole position on the external profile of the TOPMAX Floor Table.

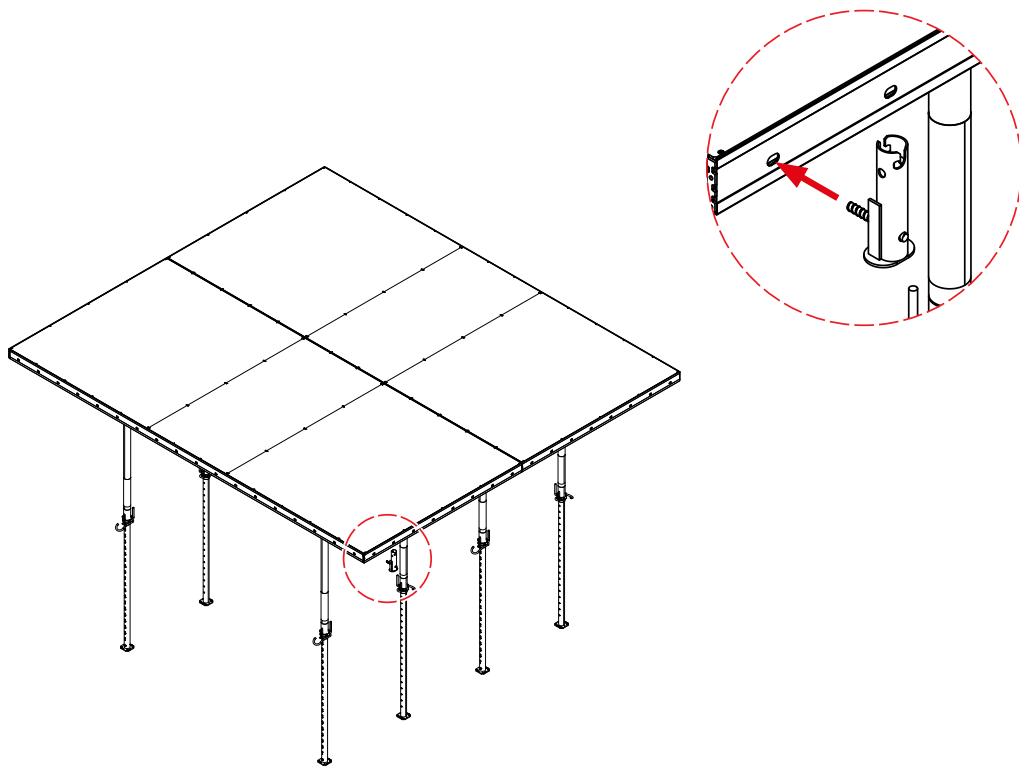

Step 2 Secure the socket base using a Centering Nut 100 (code:469566) on the inside of the external profile of the TOPMAX Floor Table.

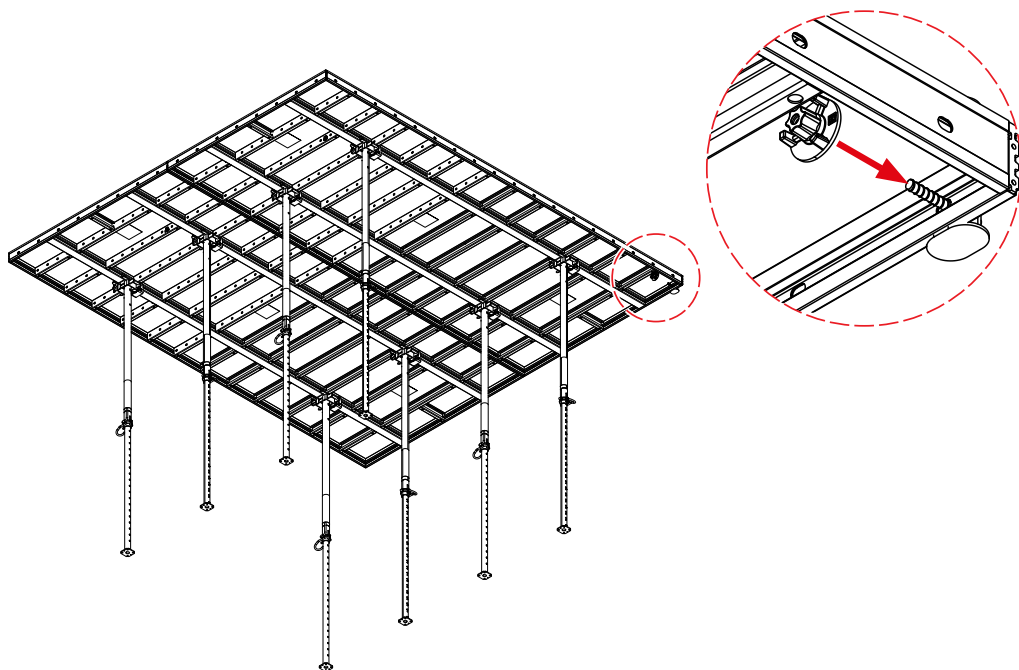

Step 3 Insert the EXTRAGUARD Guardrail Post into the socket base. The post is secure when the locking pin is located at the end of the "J" slot as shown in the detail.

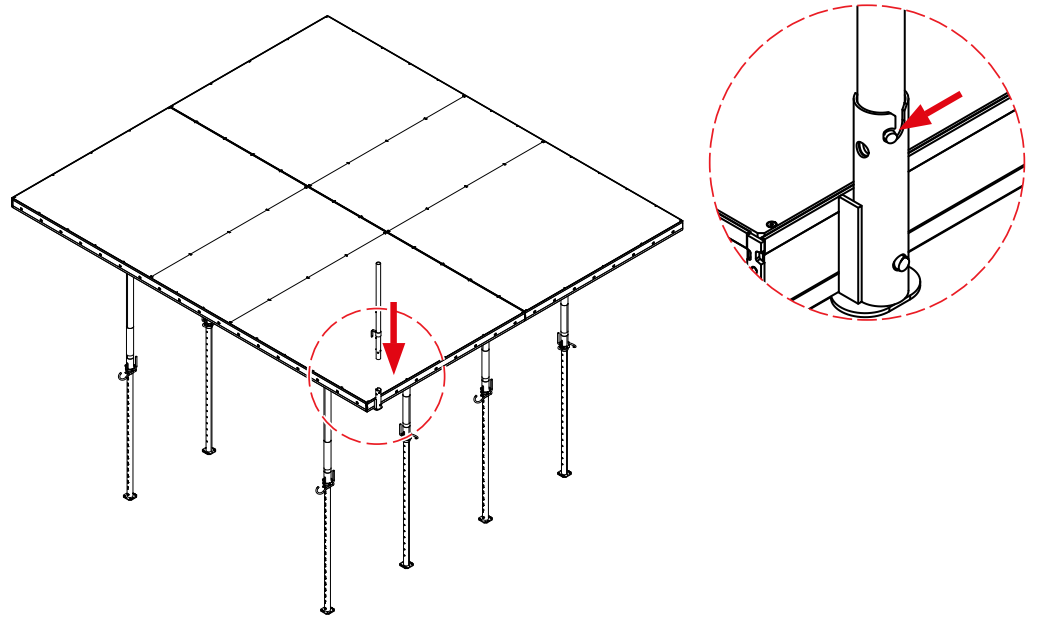

When flying TOPMAX tables with EXTRAGUARD as edge protection a Pivot Pin 16 x 100 mm (code:590850) and a Safety Pin (code:590851) is required to secure the EXTRAGUARD Guardrail Post to the TOPMAX EXTRAGUARD Socket Base (code:617605) as shown below. This is required for all post positions on the table.

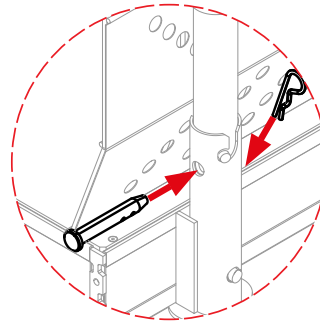

Step 4 Repeat steps 1–3 for the other post positions.

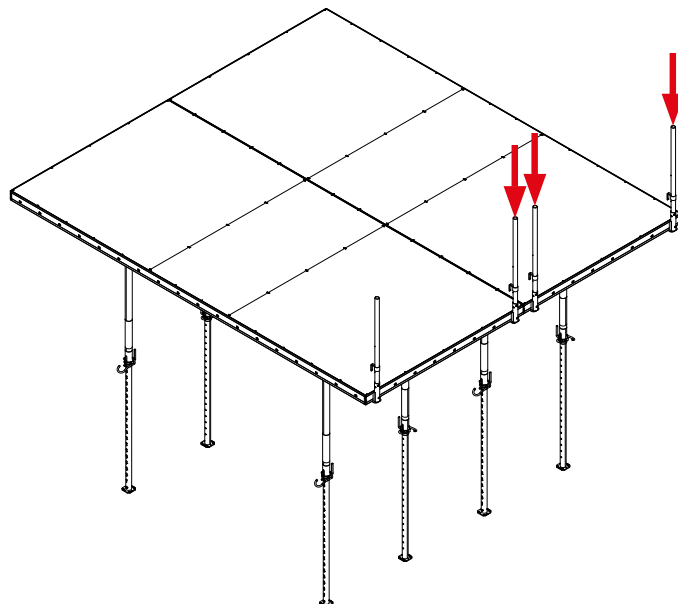



When using EXTRAGUARD Panels as edge protection, the EXTRAGUARD Guardrail Posts must not be placed more than 2.40 m apart.

Step 5 Raise the toe board bracket of the post and position the EXTRAGUARD Panels on the EXTRAGUARD Guardrail Post.

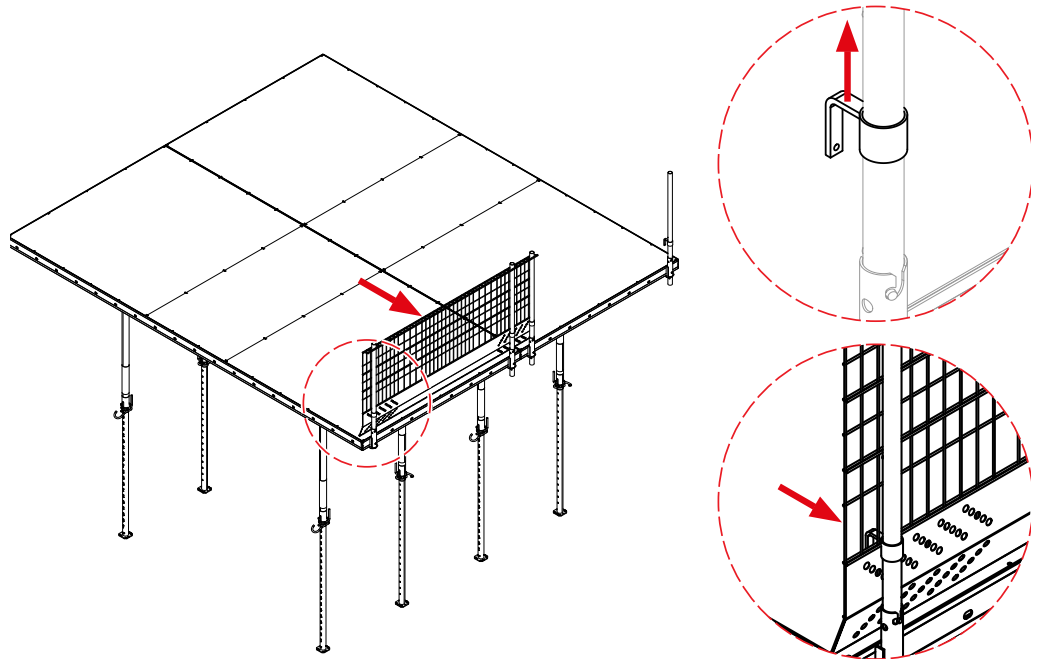

Step 6 Lower the toe board bracket and ensure that the post protrudes through the mesh at the top of the panel.

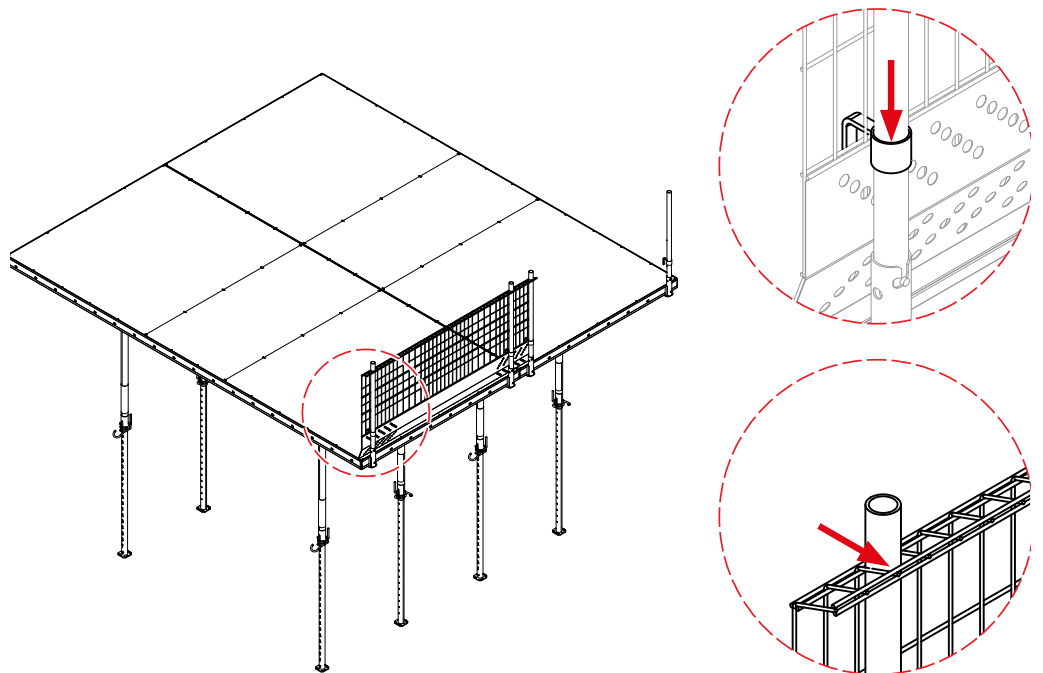

Step 7 Repeat steps 5–6 for the other panel positions.

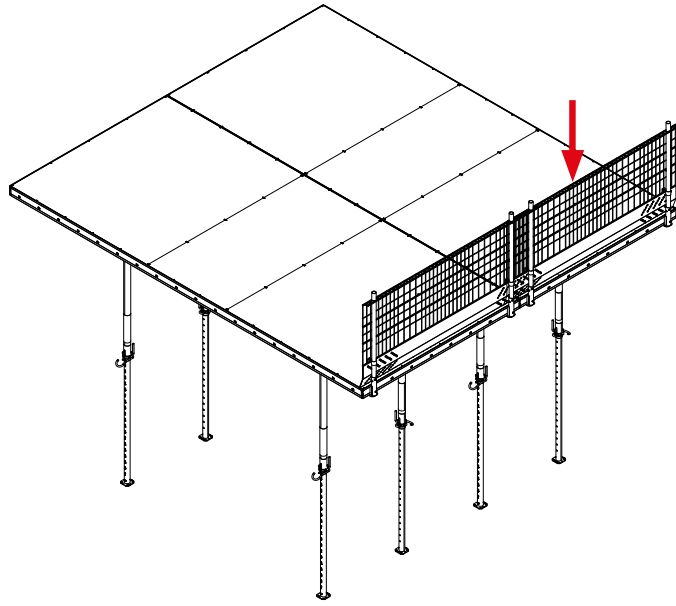

5.7 Stabilizing aids

5.7.1 Struts

Struts are typically used to stabilise and secure the TOPMAX tables when these are placed near the leading edges of existing structures.

Always make sure that the deck level of TOPMAX tables is laterally stable in all directions. This can be achieved by butting against the existing structure or by bracing using Wall Struts. The struts can be attached to both sides of the TOPMAX Floor Table.

Wall Struts are secured to the profiles of the TOPMAX Floor Tables using 1no. Centering Tension Bolt (code:479264) and 1no. Centering Nut (code:469566) per strut.

The strut Safe Working Load depends on the load carrying capacity of the frame profile:

- Max. H permitted: 5.00 kN
- Max. strut load ($\alpha = 45^\circ$): 7.10 kN
- Max. strut load ($\alpha = 60^\circ$): 10.10 kN

- Step 1** Insert a Centering Tension Bolt (code:479264) into the required position on the inner profile of the TOPMAX Floor Table.

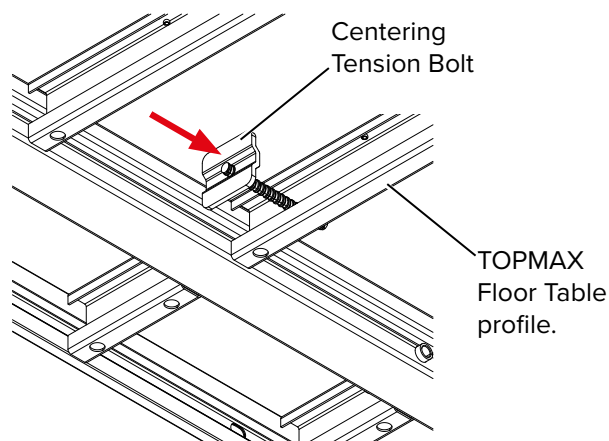

- Step 2** Insert the Wall Strut through the threaded rod of the bolt.

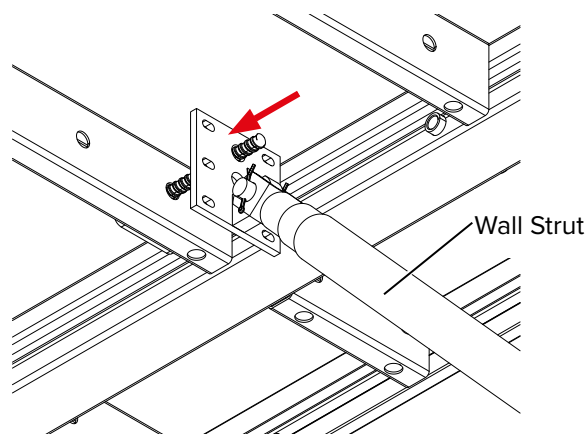

Step 3 Secure the strut by inserting a Centering Nut 100 (code:469566) through the threaded rod of the bolt and tighten.

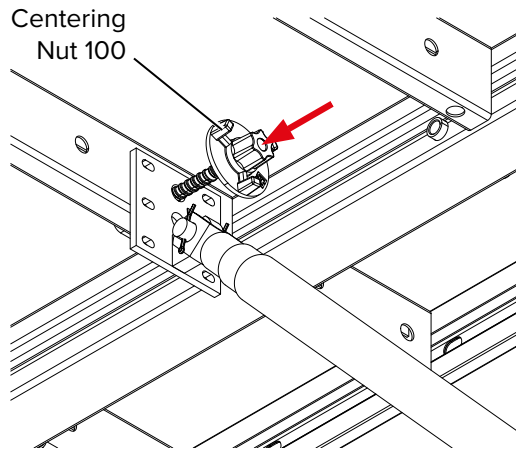

Please note the correct position of strut when attached to the "C" profiles of the TOPMAX Floor Table.

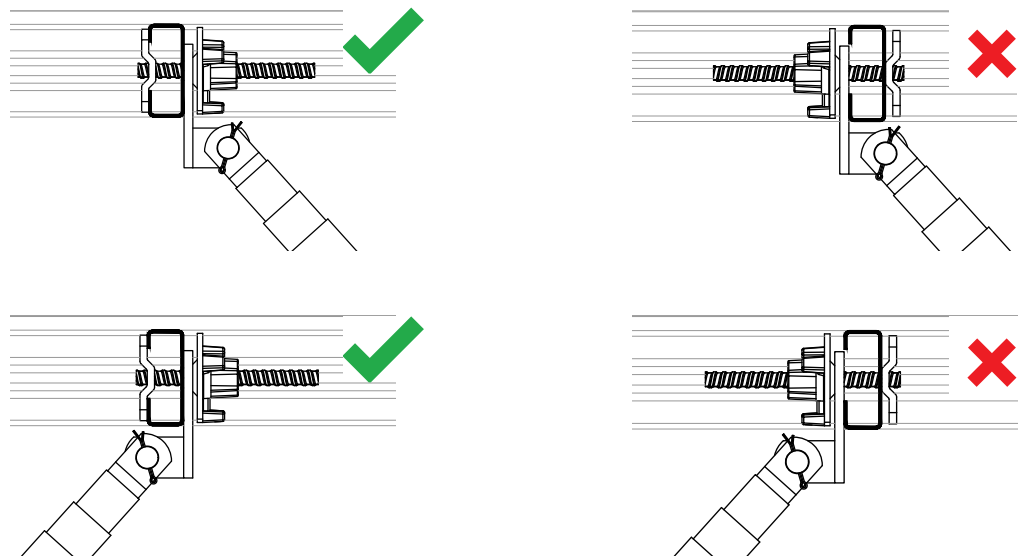

Regardless of the direction of the strut, always attach the wall struts to the closed side of the C profile and fixed at maximum of 190 mm from the main profiles (edge profile or main inner profile) as shown below.

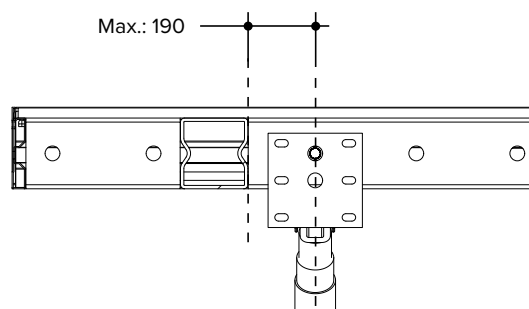

It is possible to use the struts to achieve restraint in the other direction. In this case the strut can be attached to the stiffener profile (see note above) or anywhere on the long side profile.

Some possible positions to attach the strut in the other direction are shown below.

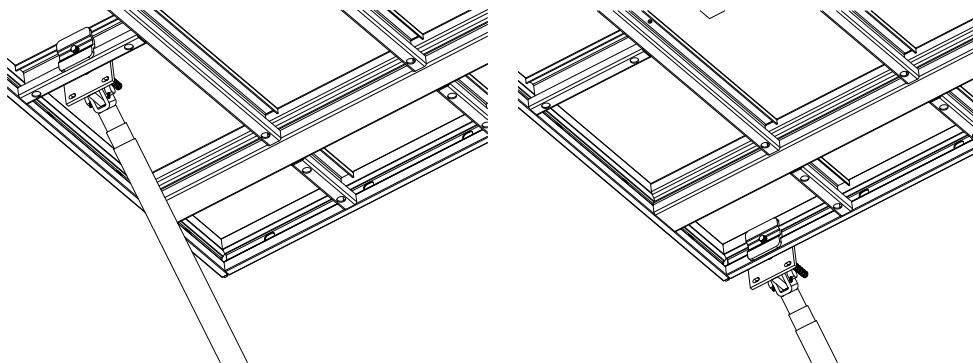

5.7.2 Anchors

Panel Anchor Bracket

The Panel Anchor Bracket (code:605999) can be used to prevent lateral movement of TOPMAX tables. It is fixed to existing wall at the table head level and replaces Wall Struts for horizontal restraint. Vertical loads must be supported by the table props.

The bracket has two staggered Ø18 holes on opposite faces for installing the anchor bolt. Two Ø36 holes are aligned with the smaller holes on the opposite face and allow for the spanner extension to be used to fasten the anchor bolt.

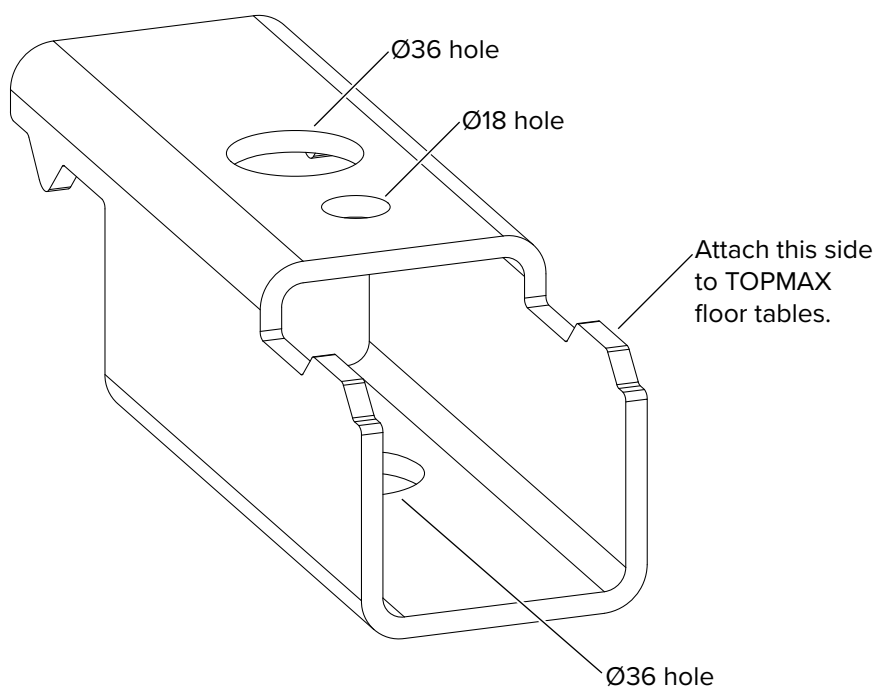

The Panel Anchor Bracket (code:605999) is secured using the Anchor Bolt MM + SSK 16 x 130 (code:443500). Only one anchor is required per bracket. To fasten the anchor bolt use a 24 mm spanner with a spanner extension.

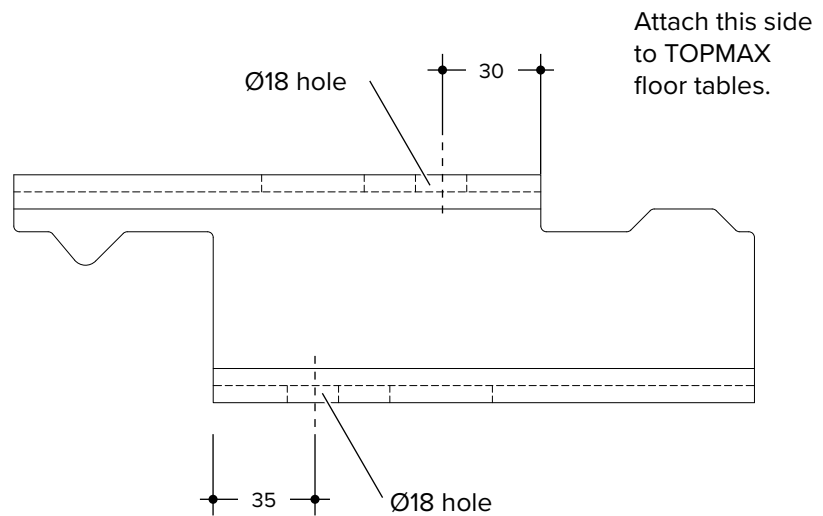

The Panel Anchor Bracket (code:605999) can be attached to TOPMAX panels as shown below to restrain the panels horizontally.

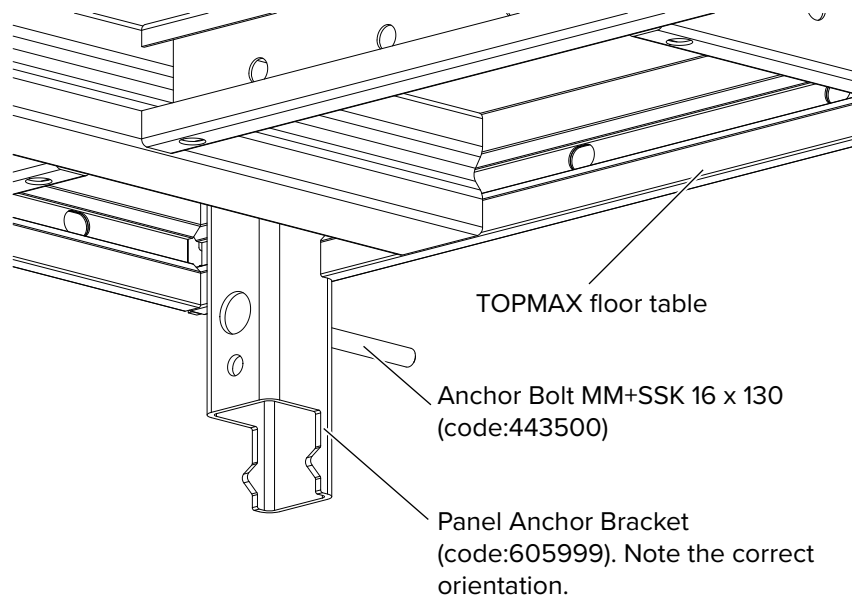

WARNING

Risk of damage and / or injury!

This application is for horizontal loads only, vertical loads to be taken by props.

The Customer is responsible for verifying that the concrete strength of the existing structure is in accordance with the specifications shown in page 86.



For more information regarding the Anchor Bolt MM+SSK 16 x 130 (code:443500) see page 84. Data sheets are also available upon request.

Installation:

- Step 1** Place the Panel Anchor Bracket (code:605999) at the edge profile of the TOPMAX Floor Table at the location specified by the supplied scheme.
- Step 2** Pass a Ø14 drill bit through the Ø18 hole of the Panel Anchor Bracket (code:605999) and mark where the hole should be drilled. Remove the Panel Anchor Bracket.
- Step 3** Use a Ø14 drill bit to drill a 134 mm hole in the existing structure.
- Step 4** Remove dust from the drilled hole.
- Step 5** Place the Panel Anchor Bracket (code:605999) at the edge profile again, insert the Anchor Bolt through the Ø36 hole and screw tight using a 24 mm spanner with an extension.
- Step 6** Ensure that the Panel Anchor Bracket (code:605999) is securely bolted.

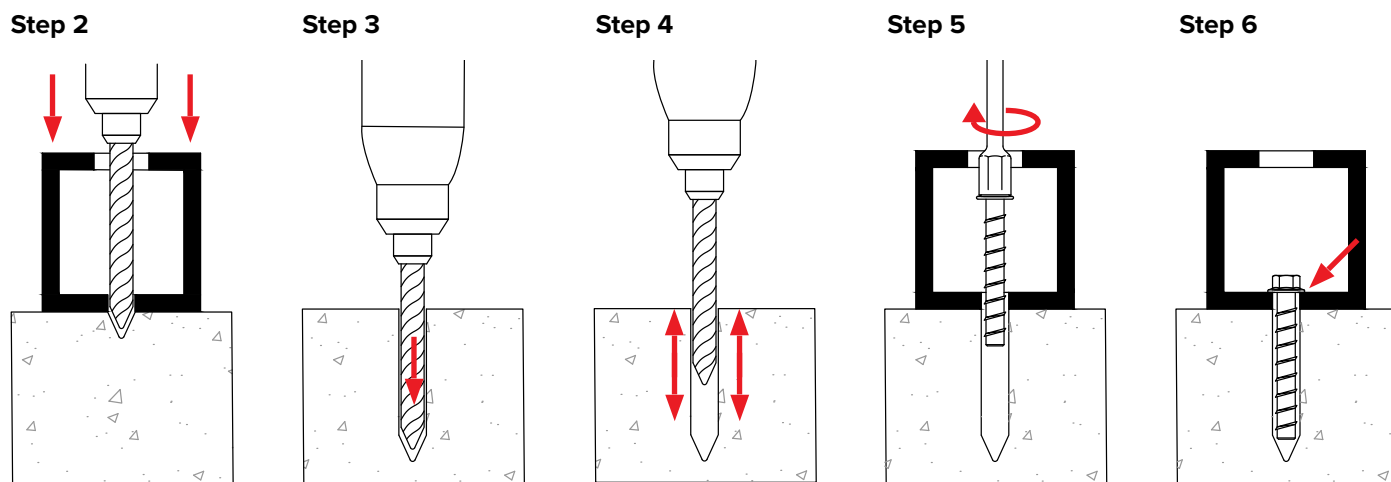

Anchor Bolt MM+SSK 16 x 130

The Anchor Bolt MM+SSK 16 x 130 (code:443500) is used to temporarily secure the components to the existing structure. The bolt can be tightened using a 24 mm spanner.

Bottom plate of the Panel Anchor Bracket (code:605999).

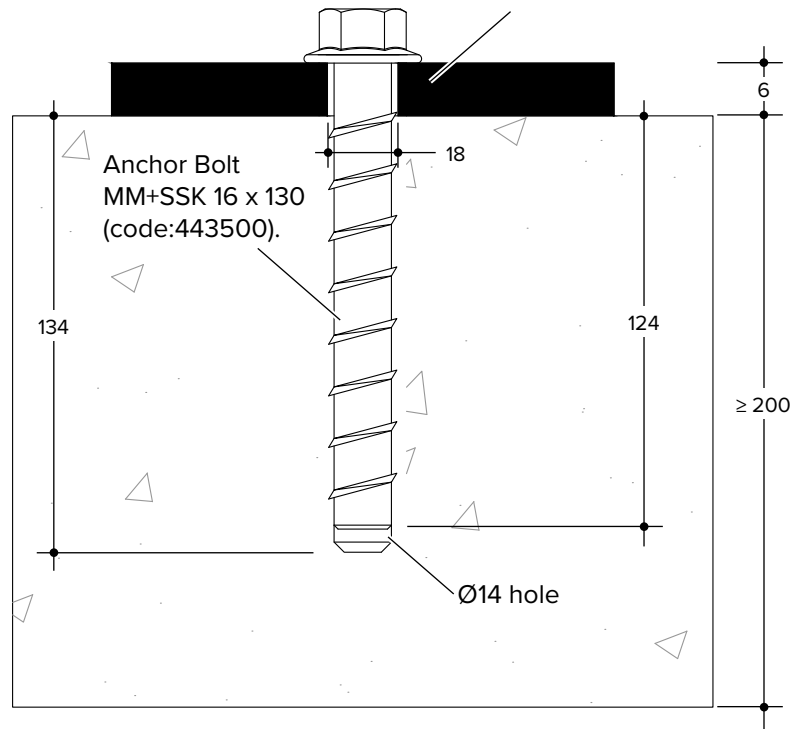

WARNING

Risk of damage and / or injury!

The Customer is responsible for verifying that the concrete strength of the existing structure is in accordance with the specifications shown in page 86.

Spacing

The spacing of the Panel Anchor Bracket (code:605999) will depend on several factors.

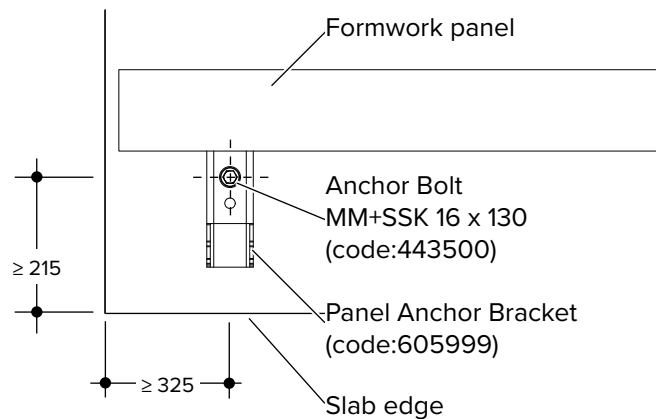

Anchor Bolt MM+SSK 16 x 130 (code:443500)		
Technical data		
Anchor length	L	130 mm
Fixing thickness	t _{fix}	15 mm
Anchoring depth	H _{nom} [L - t _{fix}]	115 mm
Depth of drilled hole	H ₁	125 mm
Drill [Ø]	d ₀	14 mm
Drill bit cutting [Ø]	d _{cut}	14.5 mm
Installation torque	T _{inst}	N/A
Spanner size	w.a.f.	24 mm
Minimum spacing	s	≥ 645 mm
Minimum edge distance	c	215 / 325 mm
Minimum concrete thickness	d	≥ 200 mm
Hole in part to be fixed	d _f	17–23 mm

Re-using anchor bolts:

When re-using anchor bolts check the bolt beforehand with the Checking Gauge (code:443501).

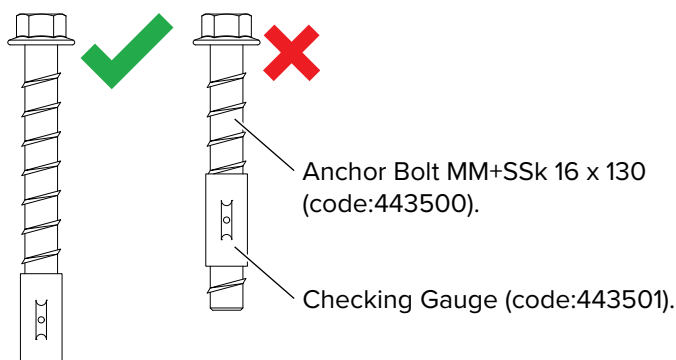

! WARNING	Risk of damage and / or injury! Do not use anchor bolts with visible damage, e.g. corrosion. Damaged bolts must be disposed of.
------------------	----------------------------------------------------------------------------------------------------------------------------------------------

! WARNING	Risk of damage and / or injury! If a hole is drilled incorrectly, a new hole must be drilled at a distance equal to at least twice the depth of the incorrectly drilled hole. Anchors can be re-used but the same hole must not be used a second time.
------------------	---------------------------------------------------------------------------------------------------------------------------------------------------------------------------------------------------------------------------------------------------------------------

Safe Working Loads

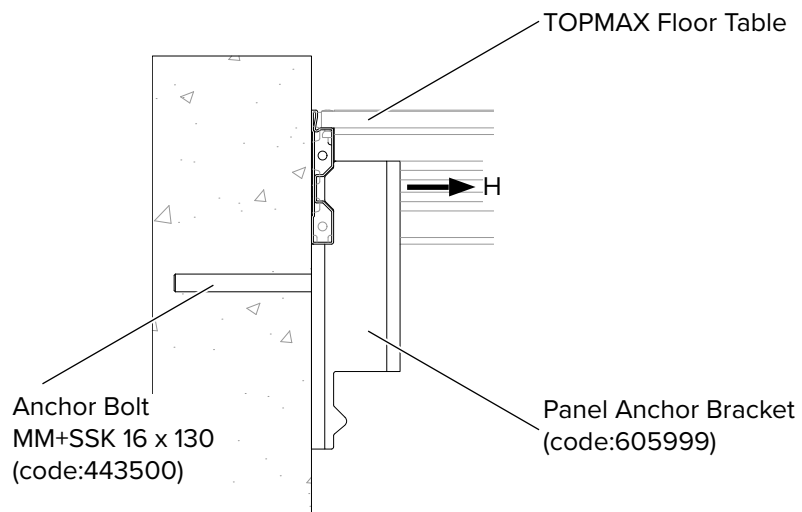

Panel Anchor Bracket (code:605999) + Anchor Bolt MM+SSK 16 x 130 (code:443500)				
with TOPMAX Floor Table				
Horizontal load - Safe Working Loads				
	Concrete strength			
	25 N/mm ²	20 N/mm ²	15 N/mm ²	10 N/mm ²
H [kN]	9.42	8.42	7.28	5.95

5.8 Infills

5.8.1 Infills using plywood

- Step 1** Attach the hook of the TOPMAX Timber Holder (code:603235) to the hole of the external profile of the TOPMAX Floor Table.

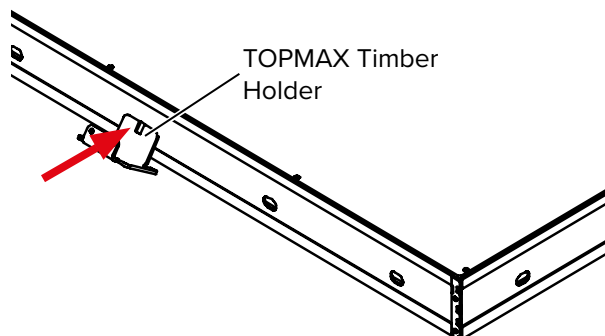

- Step 2** Attach as many holders as required. See load tables at the end of assembly sequence..

- Step 3** Place a 8 x 10 cm timber with an adequate length onto the row of TOPMAX Timber Holders (code:603235). The maximum cantilever length is 300 mm.

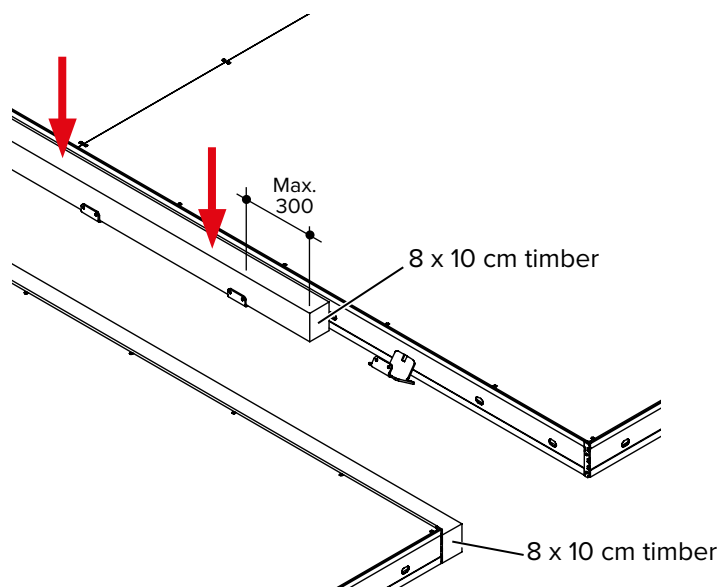

- Step 4** Secure the timber with nails.

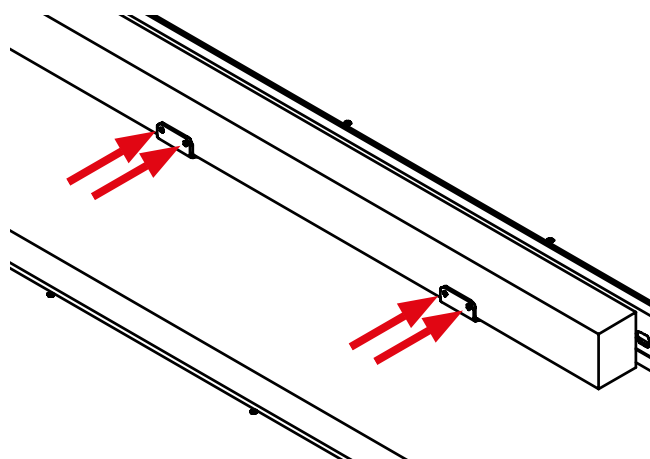

- Step 5** Repeat steps 1–4 for the opposite side.
- Step 6** Assemble the mid-span support as determined by the schemes supplied. The full length of the 8 x 10 cm timber and some TOPMAX Timber Holders (code:603235) not shown below for clarity.

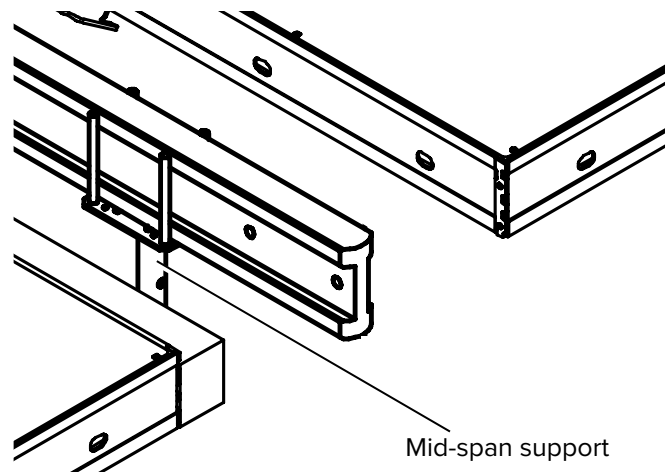

- Step 7** Cut the plywood to size and place on the infill area. Secure to 8 x 10 cm timber using nails.

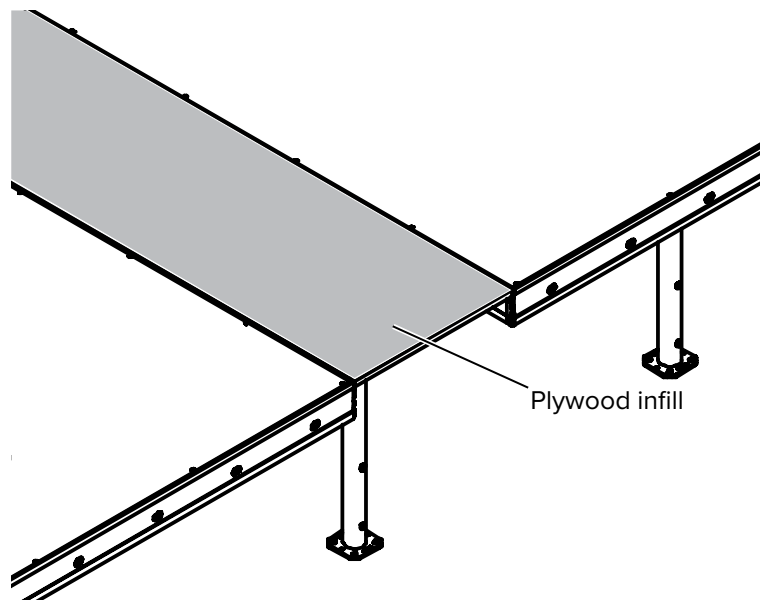

Infill lengthwise without mid-span support

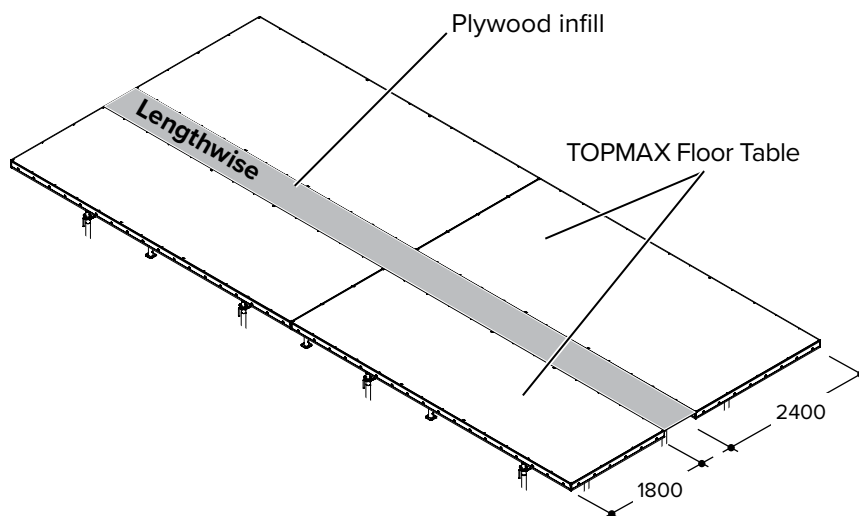

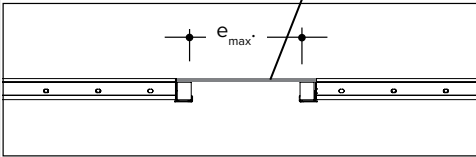
Infills lengthwise without mid-span support (table size 2.4 x 5.4 m)						
Loads to DIN EN 12812						
Slab thickness [mm]	$e_{min.}$ [m]	$e_{max.}$ [m]	Timber holders (max. distance) [m]	Additional prop load _{min.} [kN]	Additional prop load _{max.} [kN]	Plywood 21 mm, Quality F25/10 (DIN 68792) 
150	0.20	0.67	0.90	2.13	7.14	
200	0.20	0.63	0.90	2.63	8.31	
250	0.20	0.60	0.60	3.14	9.41	
300	0.20	0.57	0.60	3.65	10.47	
350	0.20	0.55	0.60	4.20	11.55	
400	0.20	0.45	0.60	4.76	10.81	
450	0.20	0.25	0.60	5.32	6.52	
500	-	-	-	-	-	

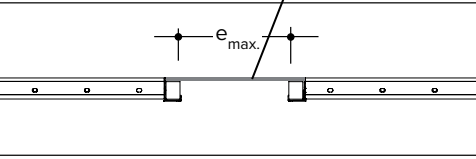
Infills lengthwise without mid-span support (table size 1.8 x 5.4 m)						
Loads to DIN EN 12812						
Slab thickness [mm]	$e_{min.}$ [m]	$e_{max.}$ [m]	Timber holders (max. distance) [m]	Additional prop load _{min.} [kN]	Additional prop load _{max.} [kN]	Plywood 21 mm, Quality F25/10 (DIN 68792) 
150	0.20	0.67	0.90	1.77	5.95	
200	0.20	0.63	0.90	2.19	6.92	
250	0.20	0.60	0.60	2.62	7.84	
300	0.20	0.57	0.60	3.04	8.72	
350	0.20	0.55	0.60	3.50	9.66	
400	0.20	0.53	0.60	3.97	10.56	
450	0.20	0.52	0.30	4.43	11.43	
500	0.20	0.50	0.30	4.89	12.28	

 Loads shown above to be used in conjunction with tables on pages 32–34.

Infill lengthwise with mid-span support

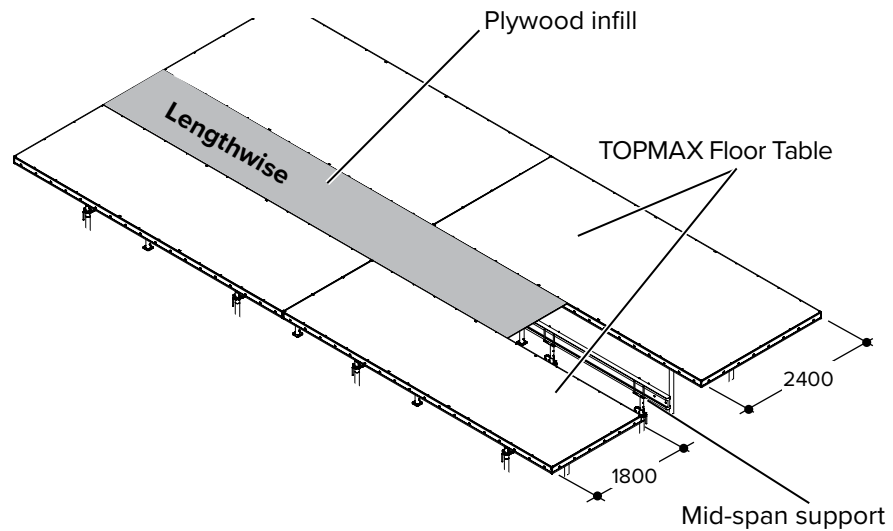

Infills lengthwise with mid-span support (table size 2.4 x 5.4 m)

Loads to DIN EN 12812

Slab thickness [mm]	$e_{min.}$ [m]	$e_{max.}$ [m]	Slab thickness (max. distance) [m]	Additional prop load _{min.} [kN]	Additional prop load _{max.} [kN]
150	0.30	1.66	0.90	1.20	6.64
200	0.30	1.56	0.90	1.48	7.68
250	0.30	1.47	0.90	1.77	8.66
300	0.30	1.40	0.60	2.05	9.60
350	0.30	1.34	0.60	2.36	10.58
400	0.30	1.21	0.60	2.68	10.80
450	0.30	0.65	0.60	2.99	6.52
500	0.30	0.58	0.60	3.30	6.30

Plywood 21 mm, Quality F25/10 (DIN 68792)

Safe Working Load (vertical):
TOPMAX Timber Holders:
 $V_{perm.} = 1.90$ kN

Infills lengthwise with mid-span support (table size 1.8 x 5.4 m)

Loads to DIN EN 12812

Slab thickness [mm]	$e_{min.}$ [m]	$e_{max.}$ [m]	Timber holders (max. Abstand) [m]	Additional prop load _{min.} [kN]	Additional prop load _{max.} [kN]
150	0.30	1.66	0.90	1.00	5.53
200	0.30	1.56	0.90	1.23	6.40
250	0.30	1.47	0.90	1.47	7.22
300	0.30	1.40	0.60	1.71	8.00
350	0.30	1.34	0.60	1.97	8.82
400	0.30	1.29	0.60	2.23	9.60
450	0.30	1.25	0.60	2.49	10.36
500	0.30	1.21	0.30	2.75	11.10

Plywood 21 mm, Quality F25/10 (DIN 68792)

Safe Working Load (vertical):
TOPMAX Timber Holder:
 $V_{perm.} = 1.90$ kN



The loads shown on the tables above do not apply to the props used for mid-span support. Mid support props and beams have to be checked separately. Loads shown above to be used in conjunction with tables on pages 32–34.

Infills crosswise without mid-span support

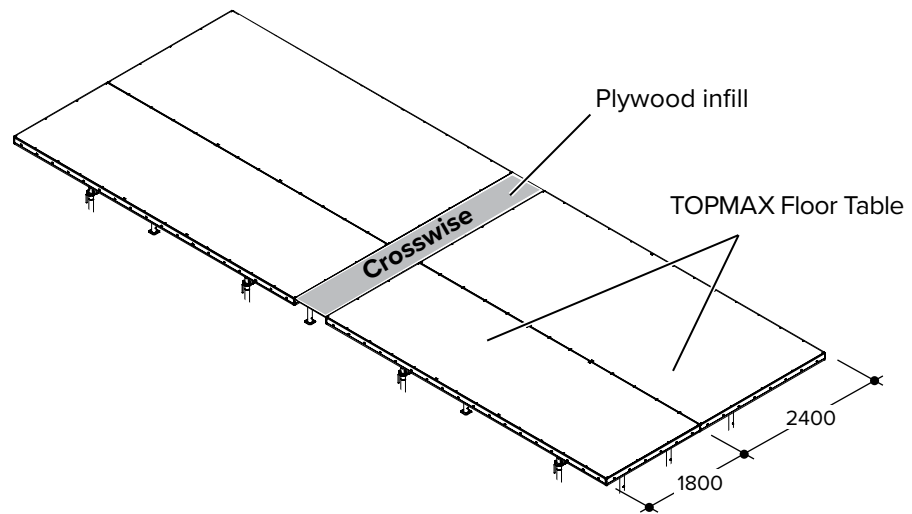

Infills crosswise without mid-span support (table size 2.4 x 5.4 m)					
Loads to DIN EN 12812					
Slab thickness [mm]	$e_{min.}$ [m]	$e_{max.}$ [m]	Timber holders (max. distance) [m]	Additional prop load _{min.} [kN]	Additional prop load _{max.} [kN]
150	0.20	0.67	0.90	0.88	2.96
200	0.20	0.63	0.90	1.09	3.45
250	0.20	0.60	0.60	1.30	3.50
300	0.20	0.57	0.60	1.51	4.34
350	0.20	0.55	0.60	1.74	4.81
400	0.20	0.41	0.60	1.97	4.05
450	0.20	0.25	0.60	2.21	2.72
500	-	-	-	-	-

Plywood 21 mm, Quality F25/10 (DIN 68792)

Safe Working Load (vertical):
TOPMAX Timber Holder:
 $V_{perm.} = 1.90$ kN

Infills crosswise without mid-span support (table size 1.8 x 5.4 m)					
Loads to DIN EN 12812					
Slab thickness [mm]	$e_{min.}$ [m]	$e_{max.}$ [m]	Timber holders (max. distance) [m]	Additional prop load _{min.} [kN]	Additional prop load _{max.} [kN]
150	0.20	0.67	0.90	0.66	2.22
200	0.20	0.63	0.60	0.82	2.58
250	0.20	0.60	0.60	0.98	2.53
300	0.20	0.57	0.60	1.13	3.26
350	0.20	0.55	0.60	1.31	3.61
400	0.20	0.53	0.60	1.48	3.94
450	0.20	0.52	0.30	1.65	4.27
500	0.20	0.50	0.30	1.83	4.58

Plywood 21 mm, Quality F25/10 (DIN 68792)

Safe Working Load (vertical):
TOPMAX Timber Holder:
 $V_{perm.} = 1.90$ kN

Loads shown above to be used in conjunction with tables on pages 32–34.

Infills crosswise with mid-span support

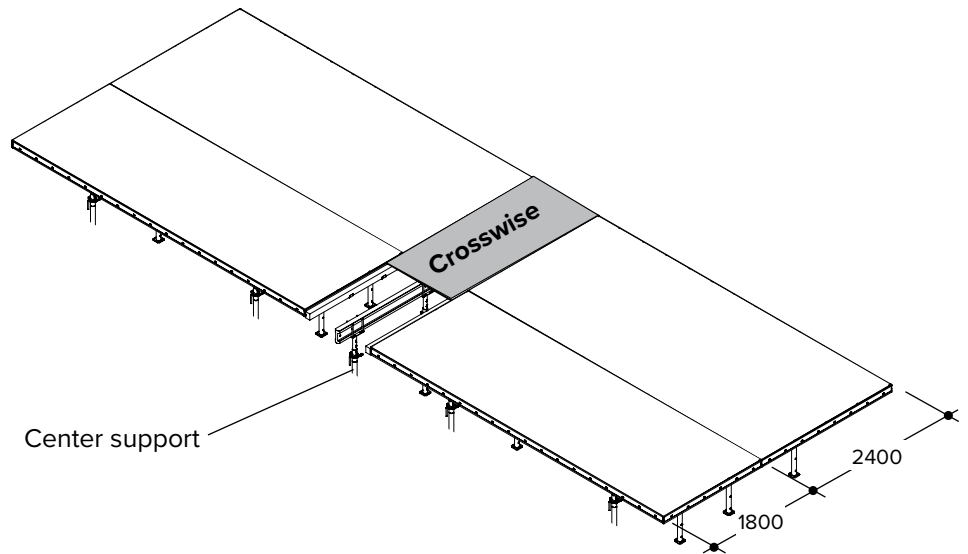

Infills crosswise with mid-span support (table size 2.4 x 5.4 m)

Loads to DIN EN 12812

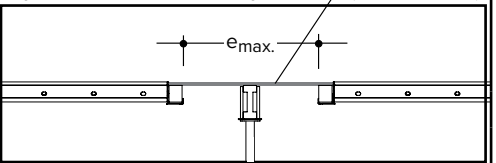
Slab thickness [mm]	$e_{min.}$ [m]	$e_{max.}$ [m]	Timber holders (max. distance) [m]	Additional prop load _{min.} [kN]	Additional prop load _{max.} [kN]	Plywood 21 mm, Quality F25/10 (DIN 68792) 
150	0.30	1.66	0.90	0.50	2.75	
200	0.30	1.56	0.90	0.61	3.19	
250	0.30	1.47	0.90	0.73	3.59	
300	0.30	1.40	0.60	0.85	3.58	
350	0.30	1.34	0.60	0.98	4.35	
400	0.30	1.09	0.60	1.11	4.05	
450	0.30	0.66	0.60	1.24	2.72	
500	0.30	0.58	0.60	1.37	2.65	

Infills crosswise with mid-span support (table size 1.8 x 5.4 m)

Loads to DIN EN 12812

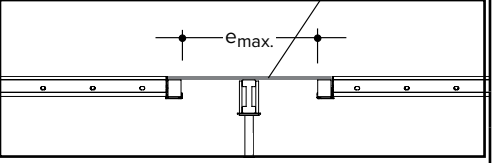
Slab thickness [mm]	$e_{min.}$ [m]	$e_{max.}$ [m]	Timber holders (max. distance) [m]	Additional prop load _{min.} [kN]	Additional prop load _{max.} [kN]	Plywood 21 mm, Quality F25/10 (DIN 68792) 
150	0.30	1.66	0.90	0.37	2.06	
200	0.30	1.56	0.90	0.46	2.39	
250	0.30	1.47	0.90	0.55	2.65	
300	0.30	1.40	0.60	0.64	2.55	
350	0.30	1.34	0.60	0.74	3.29	
400	0.30	1.29	0.60	0.83	3.59	
450	0.30	1.25	0.60	0.93	3.87	
500	0.30	1.21	0.30	1.03	4.14	



The loads shown on the tables above do not apply to the props used for mid-span support. Mid support props and beams have to be checked separately. Loads shown above to be used in conjunction with tables on pages 32–34.

Example for choosing the correct prop for infill areas

Infill lengthwise without mid-span support:

- TOPMAX Floor Table 2.4 x 5.4 m
- Slab thickness: 250 mm
- Infill width: 400 mm

In accordance with the table on page 89 and shown again below:

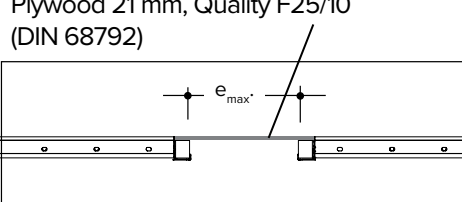
Infills lengthwise without mid-span support (table size 2.4 x 5.4 m)						
Loads to DIN EN 12812						
Slab thickness [mm]	$e_{min.}$ [m]	$e_{max.}$ [m]	Timber holders (max. distance) [m]	Additional prop load _{min.} [kN]	Additional prop load _{max.} [kN]	Plywood 21 mm, Quality F25/10 (DIN 68792) 
150	0.20	0.67	0.90	2.13	7.14	
200	0.20	0.63	0.90	2.63	8.31	
250	0.20	0.60	0.60	3.14	9.41	
300	0.20	0.57	0.60	3.65	10.47	
350	0.20	0.55	0.60	4.20	11.55	
400	0.20	0.45	0.60	4.76	10.81	
450	0.20	0.25	0.60	5.32	6.52	
500	-	-	-	-	-	

- The maximum distance between TOPMAX Tiber Holder (code:603235) is 600 mm.
- The interpolated additional prop load is 6.28 kN.

Using the table shown on page 32 and shown again below:

Permitted max. clear room height [m] for slab thickness d [mm] using 2.4 x 5.4 m tables										
d [mm]	N [kN] DIN EN 12812									
	150	200	250	300	350	400	450	500		
N [kN] DIN EN 12812	18.64	22.69	26.74	30.79	35.25	39.70	44.16	48.61		
Prop type	l [min]	Head bearing								
20-250	1.63	Head not fixed	2.62	2.62	2.42	-	-	-	-	-
		Head fixed	2.62	2.62	2.62	-	-	-	-	-
20-300	1.88	Head not fixed	3.12	3.12	3.02	2.82	2.72	-	-	-
		Head fixed	3.12	3.12	3.12	3.12	3.12	-	-	-
20-350	2.14	Head not fixed	3.62	3.62	3.62	-	-	-	-	-
		Head fixed	3.62	3.62	3.62	-	-	-	-	-
20-400	2.40	Head not fixed	4.12	4.12	3.92	3.82	-	-	-	-
		Head fixed	4.12	4.12	4.12	4.12	-	-	-	-
20-550	3.19	Head not fixed	5.62	5.62	5.32	5.02	4.82	-	-	-
		Head fixed	5.62	5.62	5.62	5.62	5.32	-	-	-
30-150	1.10	Head not fixed	1.62	1.62	1.62	1.62	1.62			
		Head fixed	1.62	1.62	1.62	1.62	1.62			
30-250	1.63	Head not fixed	2.62	2.62	2.62	2.62	-	-	-	-
		Head fixed	2.62	2.62	2.62	2.62	-	-	-	-
30-300	1.88	Head not fixed	3.12	3.12	3.12	3.12	3.02	-	-	-
		Head fixed	3.12	3.12	3.12	3.12	3.12	-	-	-
30-350	2.14	Head not fixed	3.62	3.62	3.62	3.62	3.52	3.22	3.32	2.82
		Head fixed	3.62	3.62	3.62	3.62	3.62	3.62	3.62	3.62
30-400	2.40	Head not fixed	4.12	4.12	4.12	4.12	4.12	-	-	-
		Head fixed	4.12	4.12	4.12	4.12	4.12	-	-	-

- For the 2.4 x 5.4 m floor table, the maximum load N for the required slab thickness is 26.74 kN.
- In combination with the additional prop load, the total load is 33.02 kN.

Using the tables shown on page 33 and on the following page, it is now possible to choose the suitable prop depending on the required slab height.

5.8.2 Infills using RASTO panels

Infills lengthwise

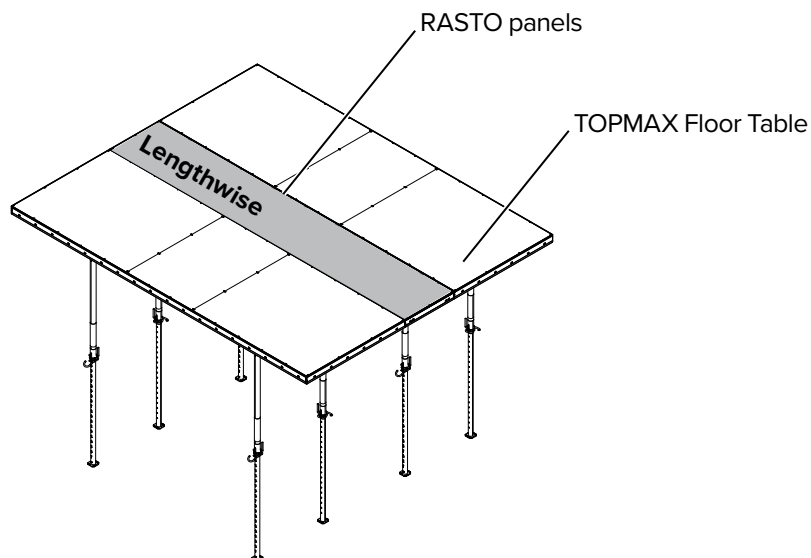

Step 1 Insert the Centering Tension Bolt (code:479264) into the hole position on the external profile of the TOPMAX Floor Table. For the maximum distance between bolts, see tables on page 96.

Step 2 Secure using the Centering Nut 100 (code:469566).

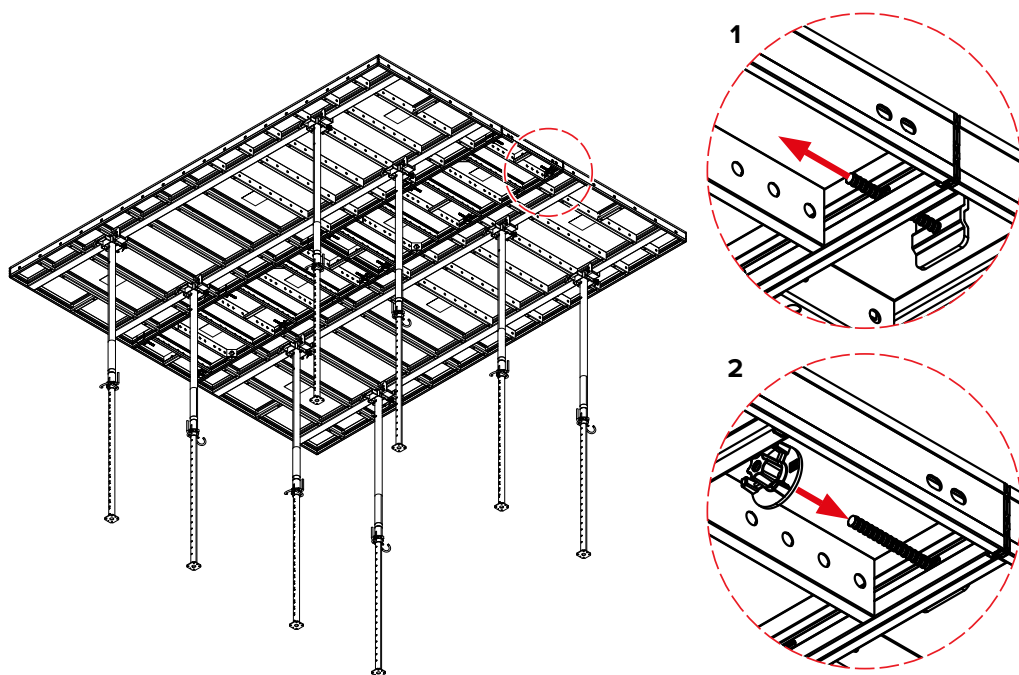

Step 3 Repeat steps 1–2 for the other connection positions including on the opposite side of the panel.

Step 4 Repeat steps 1–3 for the other panel positions.

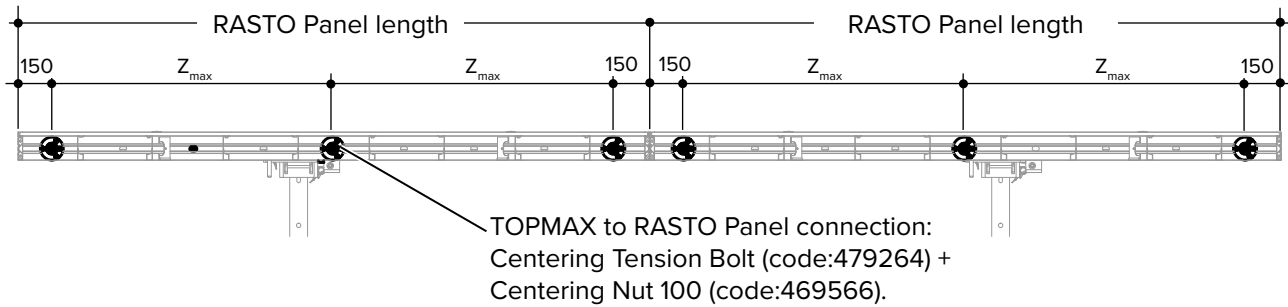

Permissible loads and connection centres

Infills lengthwise using RASTO/TAKKO Panels (table 2.4 x 5.4 m)					
Loads to DIN EN 12812					
Slab thickness [mm]	Panel width min. [m]	Panel width max. [m]	Z _{max} . [m]	Additional prop load _{min.} [kN]	Additional prop load _{max.} [kN]
150	0.30	0.90	1.50	3.43	10.30
200	0.30	0.90	1.50	4.19	12.58
250	0.30	0.90	1.20	4.95	14.85
300	0.30	0.90	1.20	5.71	17.13
350	0.30	0.65	1.20	6.55	14.18
400	0.30	0.45	1.20	7.38	11.07

Infills lengthwise using RASTO/TAKKO Panels (table 1.8 x 5.4 m)					
Loads to DIN EN 12812					
Slab thickness [mm]	Panel width min. [m]	Panel width max. [m]	Z _{max} . [m]	Additional prop load _{min.} [kN]	Additional prop load _{max.} [kN]
150	0.30	0.90	1.50	2.86	8.58
200	0.30	0.90	1.50	3.49	10.48
250	0.30	0.90	1.20	4.13	12.38
300	0.30	0.90	1.20	4.76	14.28
350	0.30	0.90	0.90	5.45	16.36
400	0.30	0.90	0.90	6.15	18.45
450	0.30	0.75	0.90	6.85	17.12
500	0.30	0.55	0.90	7.54	13.82

Infills crosswise

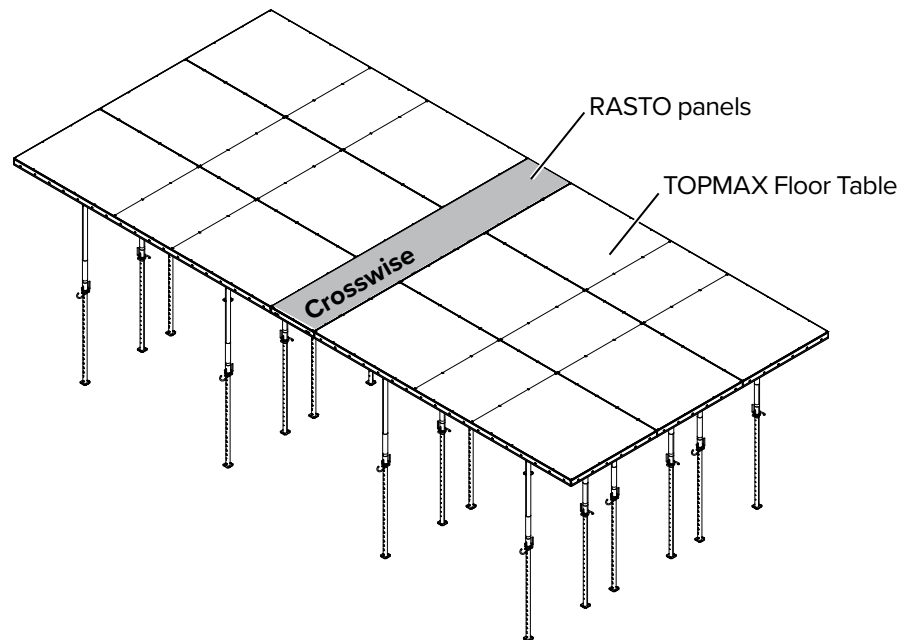

Step 1 Insert the threaded pin of the Centering Tension Bolt (code:479264) into the hole position on the external profile of the TOPMAX Floor Table. For the maximum distance between bolts, see tables on page 98.

Step 2 Secure using the Centering Nut 100 (code:469566).

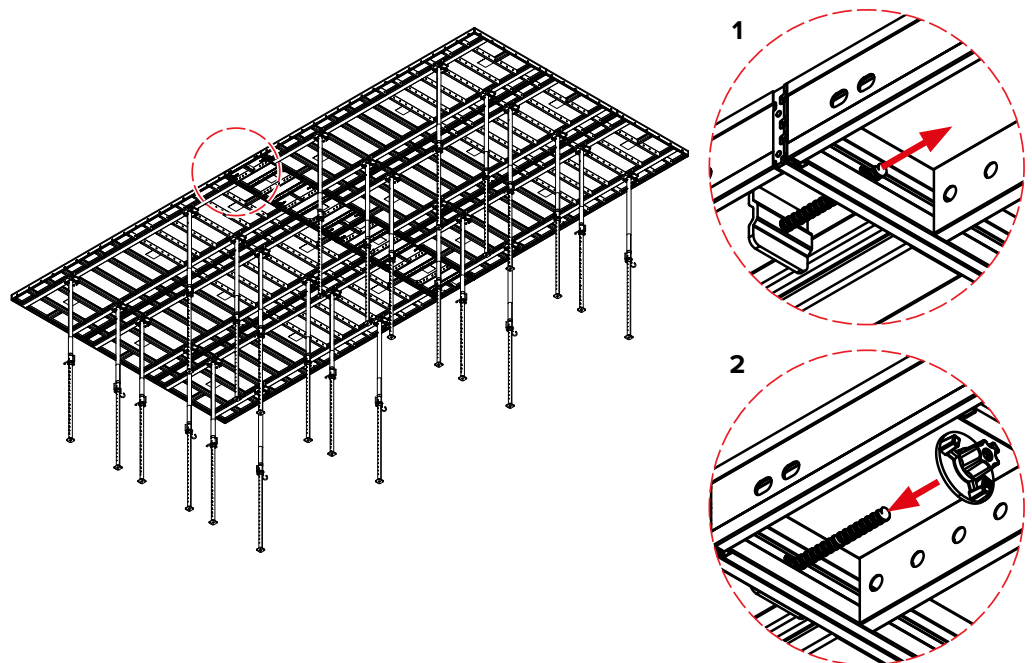

Step 3 Repeat steps 1–2 for the other connection positions including on the opposite side of the panel.

Step 4 Repeat steps 1–3 for the other panel positions.

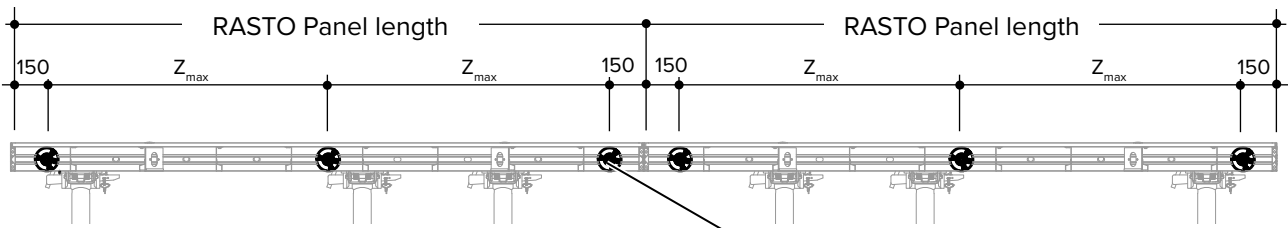

TOPMAX to RASTO Panel connection:
Centering Tension Bolt (code:479264) +
Centering Nut 100 (code:469566).

Permissible loads and connection centres

Infills crosswise using RASTO/TAKKO Panels (table 2.4 x 5.4 m)					
Loads to DIN EN 12812					
Slab thickness [mm]	Panel width min. [m]	Panel width max. [m]	Z_{max} [m]	Additional prop load min [kN]	Additional prop load max [kN]
150	0.30	0.90	1.50	1.42	4.24
200	0.30	0.90	1.50	1.74	5.22
250	0.30	0.90	1.20	2.05	6.16
300	0.30	0.90	1.20	2.37	6.86
350	0.30	0.60	1.20	2.72	5.43
400	0.30	0.30	1.20	3.06	3.06
450	---	---	---	---	---
500	---	---	---	---	---

Infills crosswise using RASTO/TAKKO Panels (table 1.8 x 5.4 m)					
Loads to DIN EN 12812					
Slab thickness [mm]	Panel width min. [m]	Panel width max. [m]	Z_{max} [m]	Additional prop load min [kN]	Additional prop load max [kN]
150	0.30	0.90	1.50	1.07	3.20
200	0.30	0.90	1.50	1.30	3.91
250	0.30	0.90	1.20	1.54	4.62
300	0.30	0.90	1.20	1.78	5.33
350	0.30	0.90	0.90	2.04	6.11
400	0.30	0.90	0.90	2.30	6.89
450	0.30	0.65	0.90	2.56	5.54
500	0.30	0.55	0.90	2.82	5.07

Propping RASTO Panels as infills

If required, the TOPMAX Prop Fixing Part (code:603141) can be used for propping the RASTO panels when used as infill panels.



A separate structural calculation is required for the support props.



WARNING

Risk of damage, collapse and/or serious injury!

Each infill panel must be supported by at least 4no. TOPMAX Prop Fixing Part (code:603141).

TOPMAX Prop Fixing Part (code:603141) must be placed over a rib of the TOPMAX Floor Table, to prevent the prop from falling.



The type, number and position of the EUROPLUSnew Props will vary depending on the job requirements. Refer to the scheme design supplied.

Step 1 Extend a suitable EUROPLUSnew Prop to the required length, see page 29.

Step 2 Insert the TOPMAX Prop Fixing Part (code:603141) into the end of the outer tube of the prop.

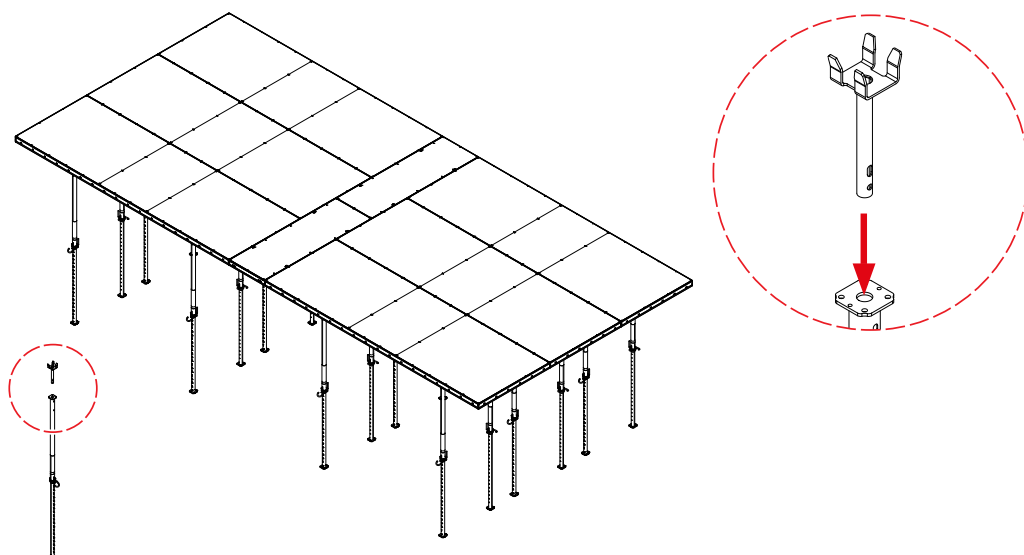

Step 3 Secure the head using a TOPEC Bolt. For the appropriate bolt to be used see page 107.

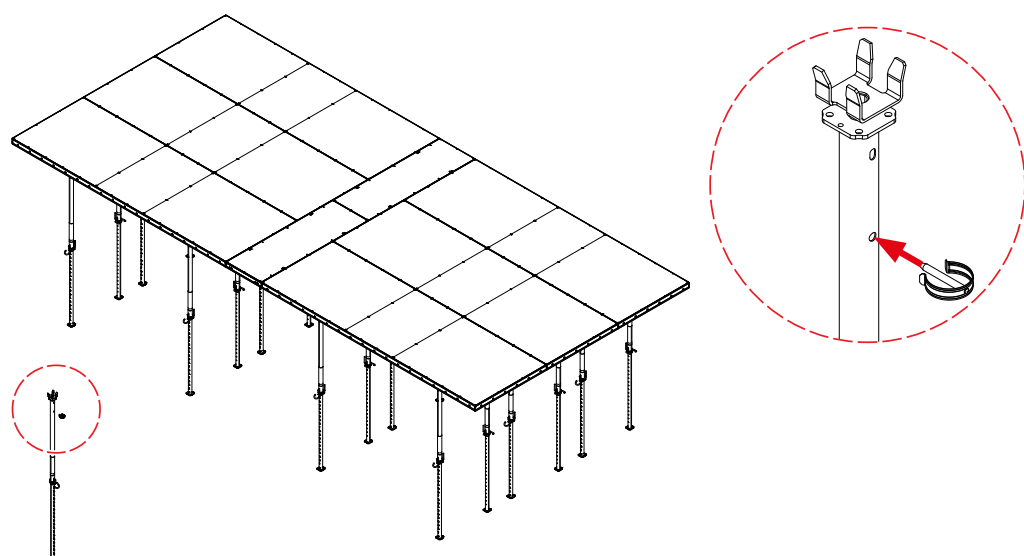

Step 4 Position the prop and head assembly in the required position, see notes on page 99.

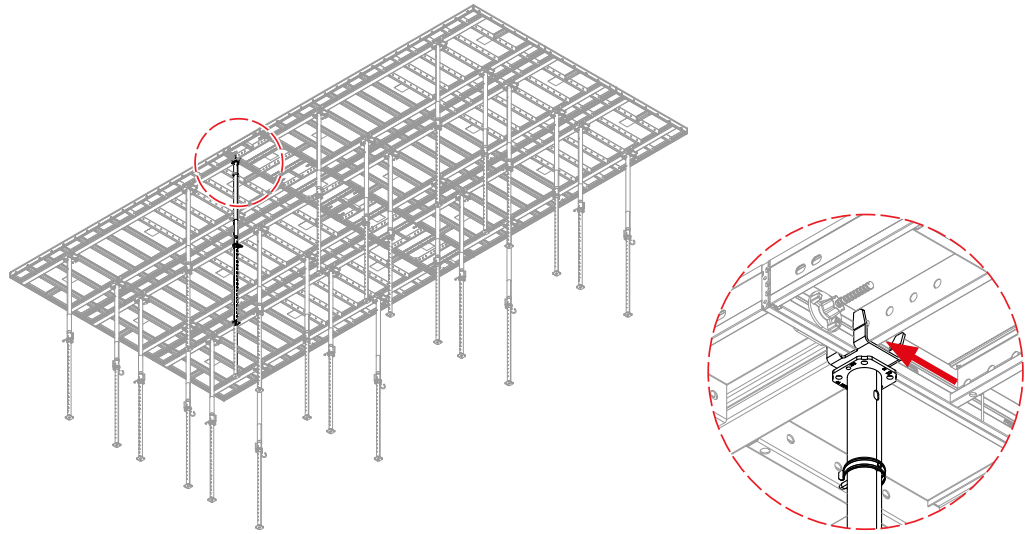

Step 5 Repeat steps 1–4 for the other prop positions.

5.8.3 Infills using TAKKO panels

TAKKO G1 Panel connection to the TOPMAX Floor Table

When using TAKKO G1 Panels as infills it is important to know that the hole pattern in the frame of the panels not similar to the one in the TOPMAX Floor Tables. The TAKKO G1 Panel can only be fixed to the TOPMAX Floor Tables using the two holes at the centre of the TAKKO G1 Panel.

For the connection, use the Centering Tension Bolt (code:479264) located on the inside of the external profile of the TAKKO G1 Panel. However, the rib of the TOPMAX Floor Table does not allow for the Centering Nut 100 (code:469566) to be used at both connection points, instead a MANTO MP Nut (code:454670) will have to be used at this position as shown below.

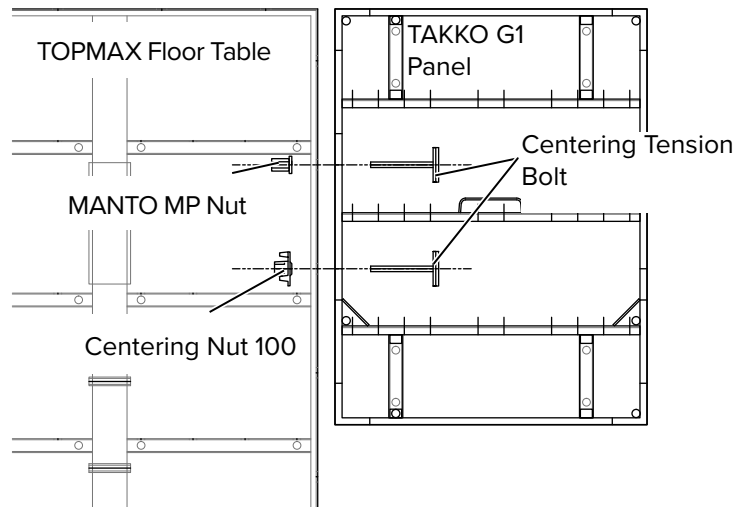

As an alternative to the MANTO MP Nut (code:454670), a Hexagon Nut 15/50 (code:164535) in combination with a Plate 8/8 (code:400214) can be used.

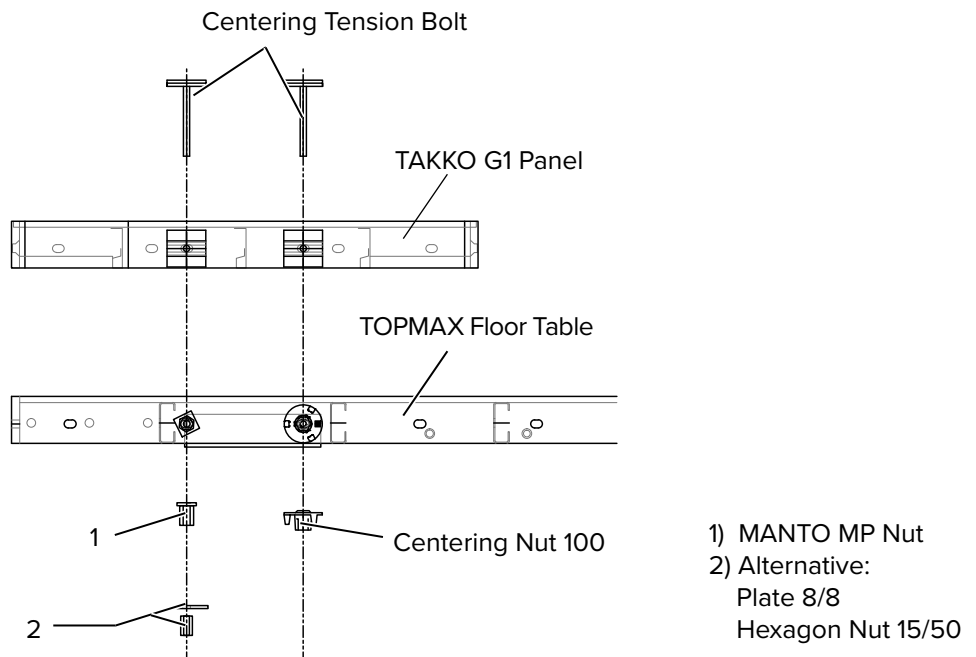

WARNING

Risk of damage, collapse and/or serious injury!

This connection can only be used as an assembly aid. For the distribution of the resulting loads, the TOPMAX Support Girder (code:603390) has to be used, see page 50.

TAKKO G2 Panel connection to the TOPMAX Floor Table

The TAKKO G2 Panels only require a Centering Tension Bolt (code:479264) and a Centering Nut 100 (code:469566) per connection, due to the fact that the hole pattern of the external profile of the new TAKKO G2 Panel aligns with the pattern of the TOPMAX Floor Table as shown below.

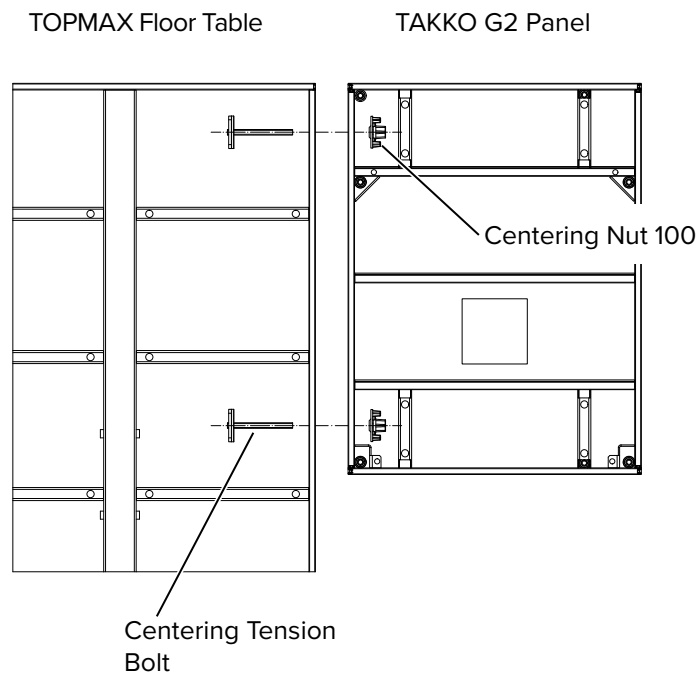
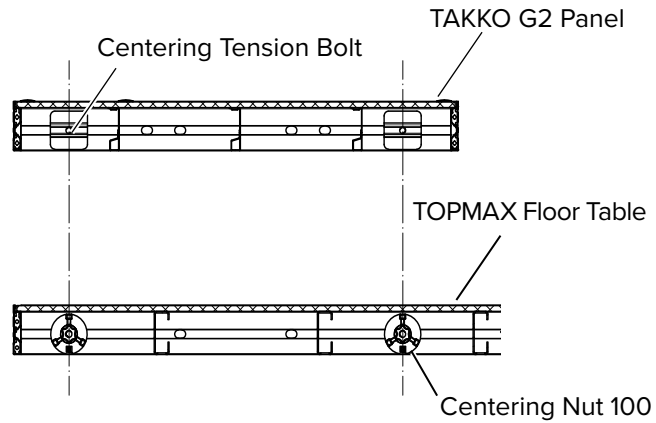

Propping TAKKO Panels as infills

TAKKO Panels are propped in the same way, using the same components and subjected to the same requirements as the RASTO Panels, see page 99.

5.8.4 Infills using TOPEC panels

The TOPMAX-TOPEC Adapter (code:604515) allows for TOPEC panels to be used as infill panels. TOPEC Panels of up to 900 mm can be used on all sides of the TOPMAX table without additional propping of the infill panels.

The TOPMAX-TOPEC Adapter (code:604515) has a SWL of 3.00 kN.

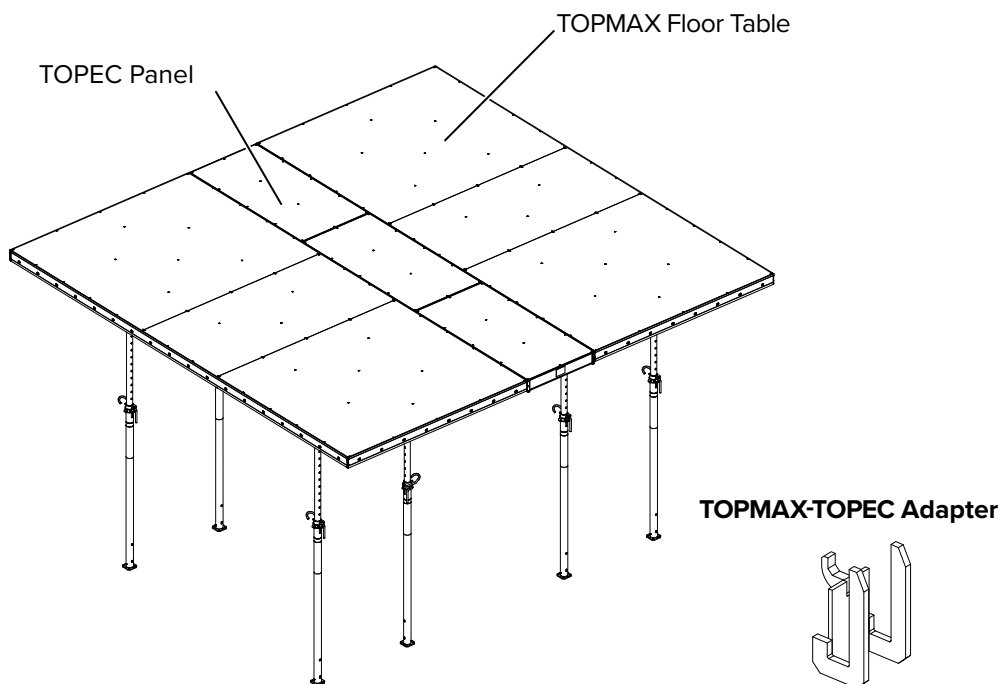

WARNING

Risk of damage, collapse and/or serious injury!

Infills wider than 900mm are not allowed.
The load bearing capacity of the TOPMAX table and of the propping has to be calculated separately.

Permissible slab thickness

Panel size [mm]	Perm. slab thickness [mm]	Adapter per panel
900/1800	220	4
750/1800	280	4
600/1800	360	4
450/1800	500	4

Step 1 Insert the hook of the TOPMAX-TOPEC Adapter (code:604515) into the slotted holes of the external profiles of the TOPMAX Floor Table.

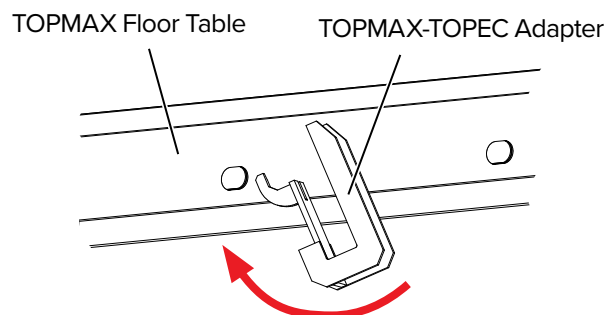

Step 2 Slot the external profile of the TOPEC panel into the exposed hook of the TOPMAX-TOPEC Adapter (code:604515) as shown in the cross-section below.



For each TOPEC Panel at least 2no. TOPMAX-TOPEC Adapter (code:604515) per side have to be used.

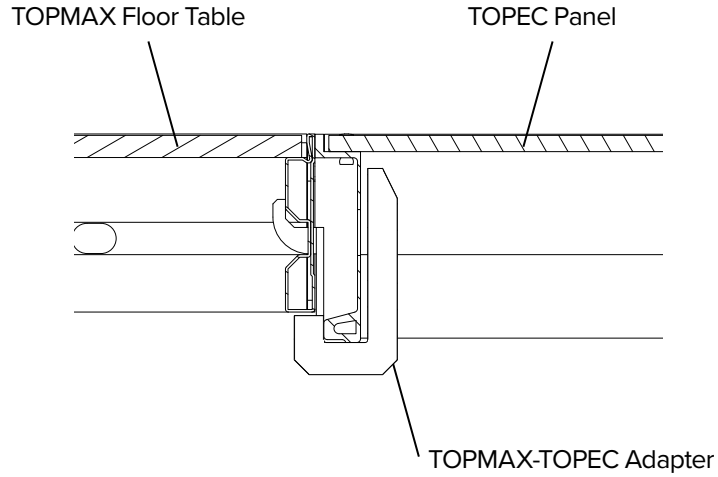

The TOPMAX-TOPEC Adapter (code:604515) must be placed at a maximum of 150 mm from the edge of the TOPEC Panel (see below).

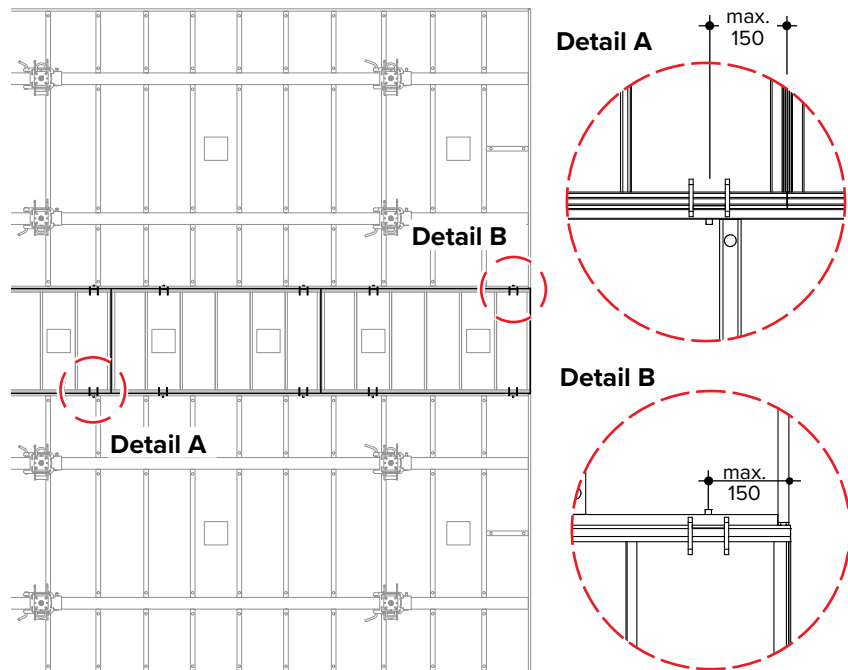

Propping TOPEC Panels as infills

When propping TOPEC panels used as infill panels the TOPMAX Connection Bearing (code:603465) is required for the corners of the TOPMAX tables adjacent to the TOPEC panels. The corners of the TOPEC Panels which are not adjacent to TOPMAX tables require a TOPEC Bearing (code:465410)

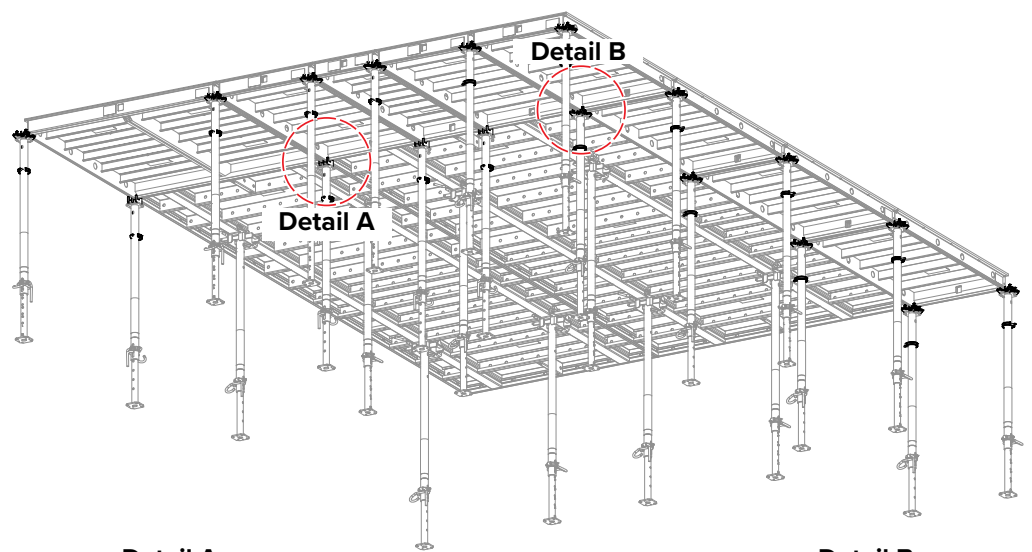
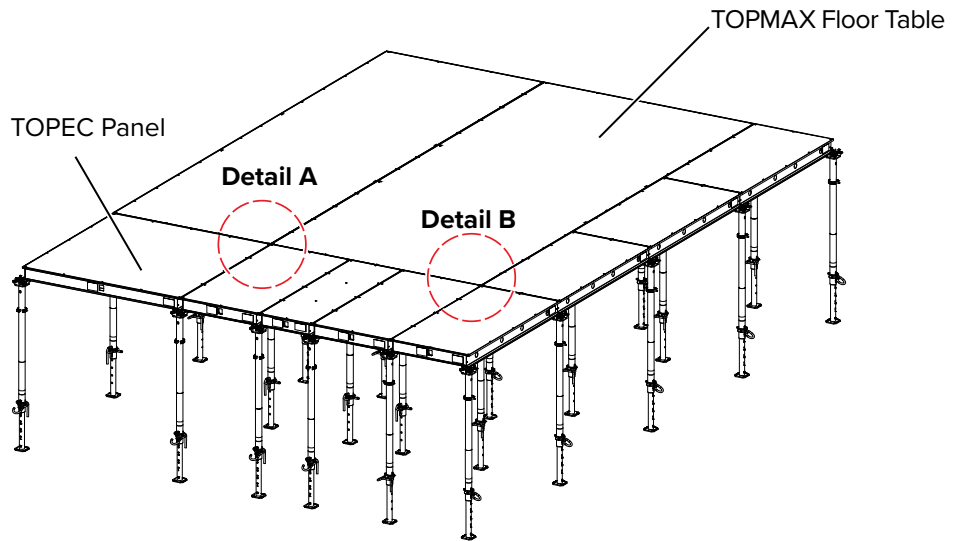

Detail A
TOPMAX to TOPEC

Detail B
TOPEC to TOPEC

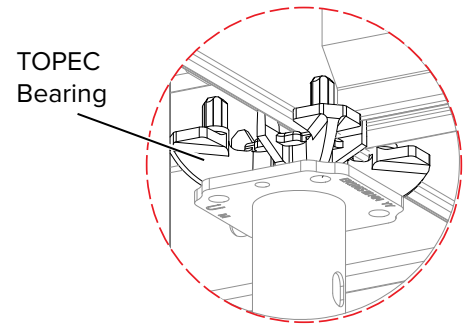
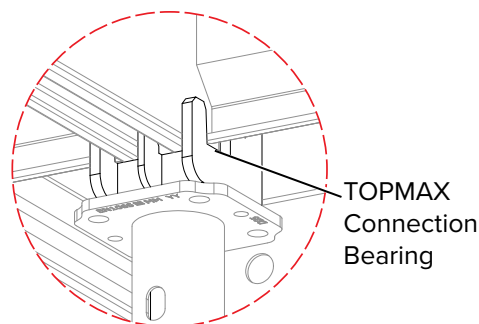

For more information regarding TOPEC refer to the separate TOPEC User Guide.

5.8.5 Infills between working platforms

Typically the TOPMAX Working Platform provides a safe continuous working platform when adjacent TOPMAX tables are connected to each other, however when an infill is required, the KG Rail Extension (code:498218) can be used to close the gaps of the guardrails.



When using the KG Rail Extension (code:498218) an additional Waler Bolt D (code:420000) and a Spring Pin 4 (code:173776) per extension is required to be ordered separately.

In markets where timber guardrail are allowed, the working platform is equipped with brackets to hold timber boards which allow a maximum infill width of 1.00 m and a minimum of 0.20 m.

A scaffold board or other timber element which complies with the relevant regulations, can be used as a toe board and secured to the toe boards of the working platform using nails. The minimum overlap of the toe boards is 450 mm.

- Step 1** Insert the guardrail extension into the guardrail of the platform.
- Step 2** Secure the extension using 1no. Waler Bolt D (code:420000) and a Spring Pin 4 (code:173776).
- Step 3** Repeat steps 1–2 for the opposite working platform.

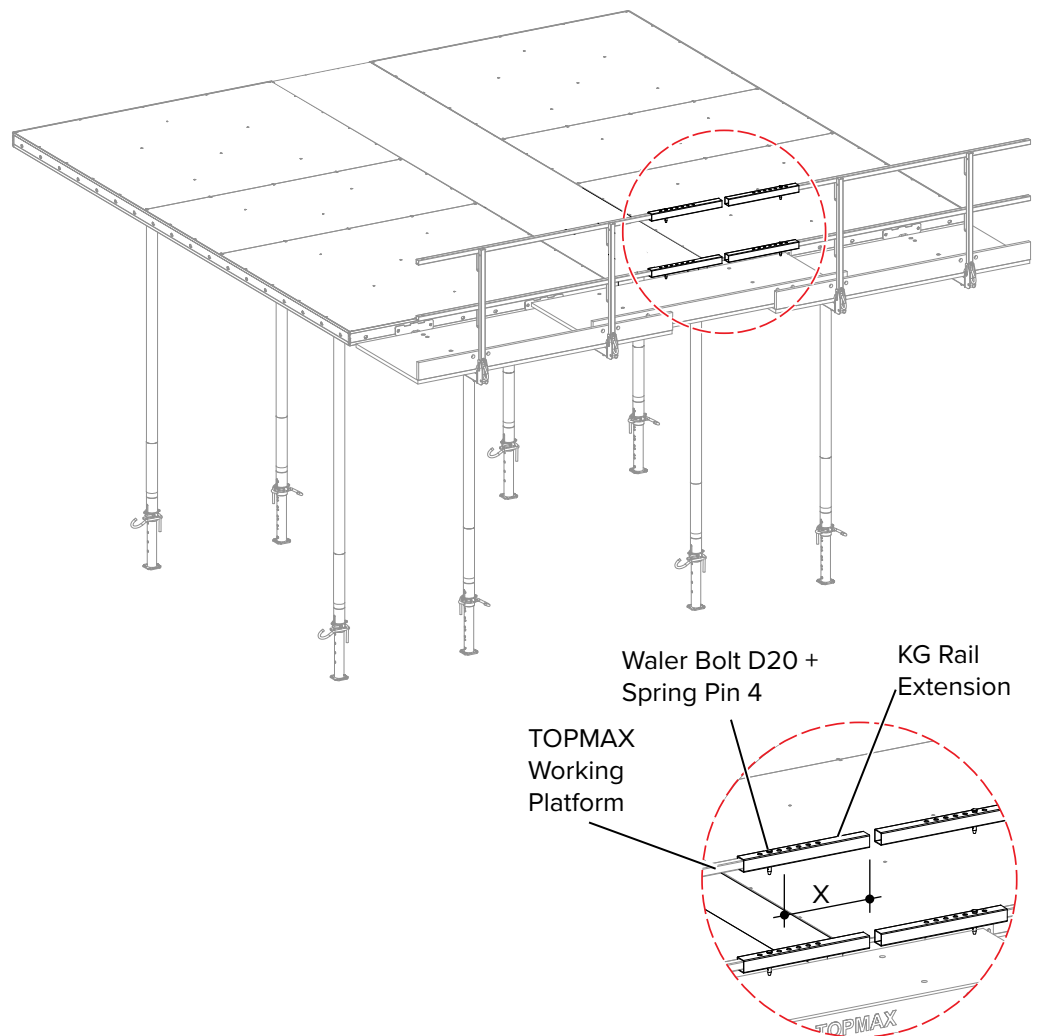

KG Rail Extensions (code:498218) are used to extend the handrails of TOPMAX Working Platform 2.4 m by $X = 0.10$ to 0.50 m and TOPMAX Working Platform 1.8 m by $X = 0.40$ to 0.50 m (measuring from the edge of the Working Platform handrail)

5.9 TOPEC Bolts

The following table shows which TOPEC Bolt is required to be used with which EUROPLUS^{new} Prop.

Description	Code	Ø [mm]	TOPEC Bolt (code:470804)	TOPEC Bolt D14 (code:604365)	TOPEC Bolt Alu 500 (code:569384)
EUROPLUS ^{new} 20-250	601390	63.5	✓	---	---
EUROPLUS ^{new} 20-300	601400	63.5	✓	---	---
EUROPLUS ^{new} 20-350	601410	76.1	---	✓	✓
EUROPLUS ^{new} 20-400	601415	76.1	---	✓	✓
EUROPLUS ^{new} 20-550	601425	88.9	---	✓	✓
EUROPLUS ^{new} 30-150	601460	63.5	✓	---	---
EUROPLUS ^{new} 30-250	601430	76.1	---	✓	✓
EUROPLUS ^{new} 30-300	601440	76.1	---	✓	✓
EUROPLUS ^{new} 30-350	601445	76.1	---	✓	✓
EUROPLUS ^{new} 30-400	601450	88.9	---	---	✓

The table above is applicable only to EUROPLUS^{new} Props when used with the outer tube up.

5.10 Stop ends

Slab edge forms are built with the TOPMAX Stopend Adjuster (code:603379), the TOPMAX Stopend Clamp (code:603432) and the TOPMAX Stopend Angle (code:603375). With the TOPMAX Stopend Clamp (code:603432) the TOPMAX Stopend Adjuster (code:603379) can be adjusted and fixed in height and in depth.

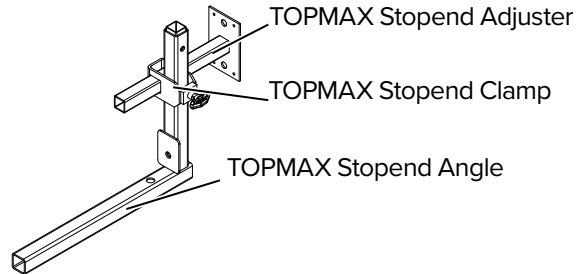

5.10.1 TOPMAX Stopend Angle outwards

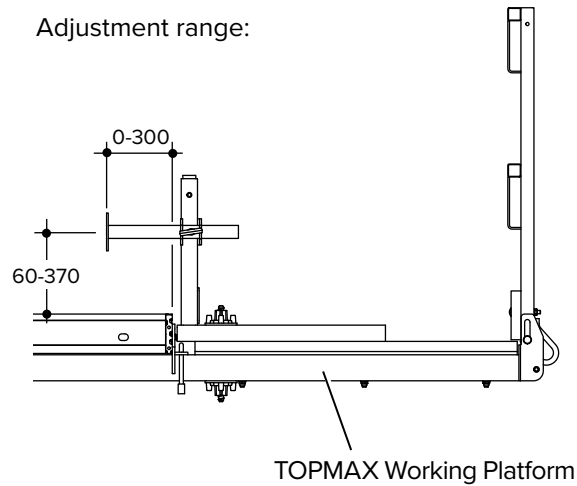

The TOPMAX Stopend Angle (code:603375) is connected to the TOPMAX Working Platform using the RASTO MP-Bolt (code:485435) through the holes of the platform and secured using 2no. Centering Nuts 100 (code:469566).

Top view

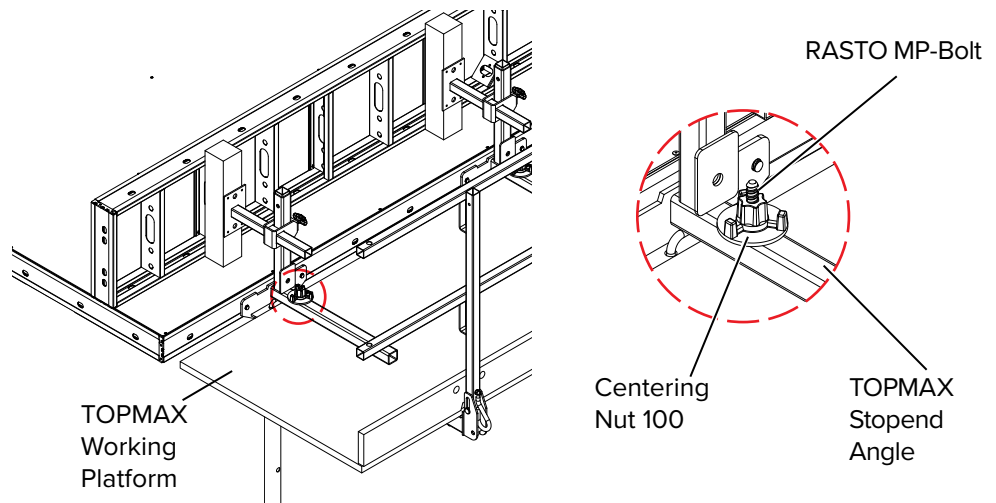

Bottom view

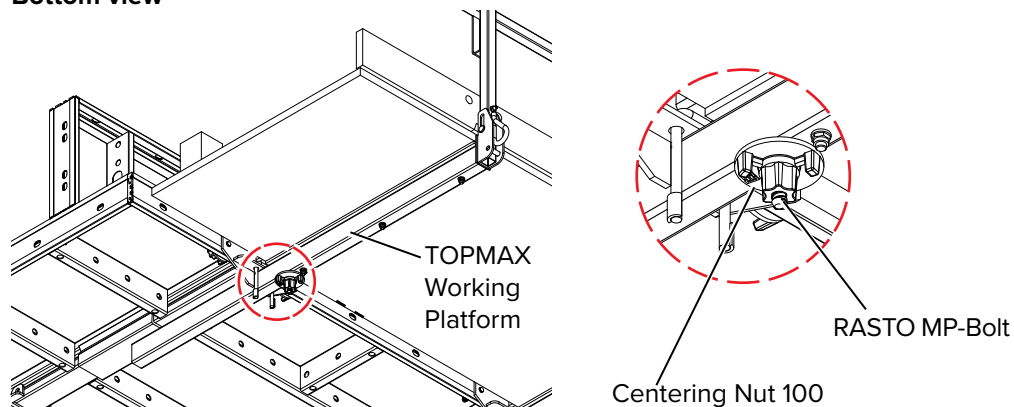

 Each TOPMAX Working Platforms requires 2no. RASTO MP-Bolts (code:485435) and 4no. Centering Nut 100 (code:469566).

5.10.2 TOPMAX Stopend Angle inwards

Adjustment range:

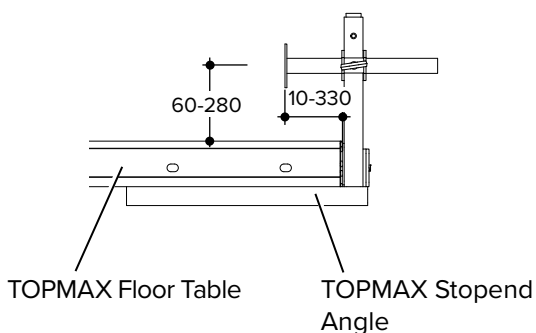

The TOPMAX Stopend Angle (code:603375) is secured to the TOPMAX Floor Table outer profile using a Centering Tension Bolt (code:479264) and a Centering Nut 100 (code:469566) located on the inside of the outer profile of the TOPMAX Floor Table (not visible below).

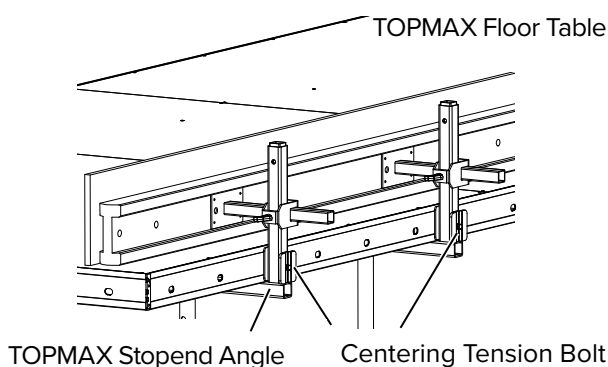

TOPMAX Stopend Angle maximum centres

Slab thickness [mm]	≤ 380	≤ 400	≤ 420	≤ 450	≤ 480	≤ 500
Distance of stopend angles [m]	2.70	2.40	2.10	1.80	1.50	1.35

The PROTECTO Railing Post (code:601225) can be inserted into the TOPMAX Stopend Angle (code:603375) to provide edge protection.

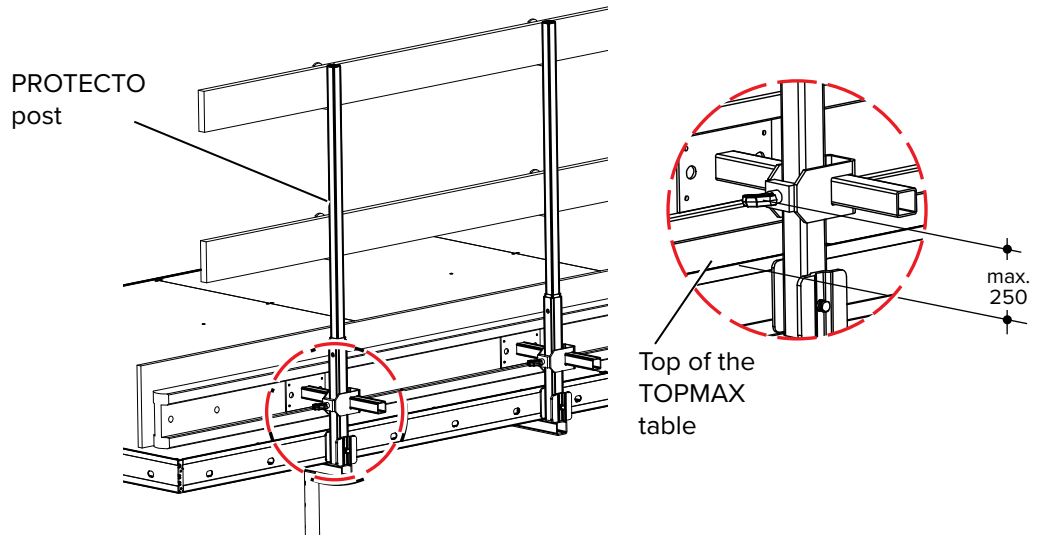

WARNING

Risk of damage, collapse and/or serious injury!

When using the PROTECTO Railing Post (code:601225), the distance between the upper edge of the slab table and the middle of the TOPMAX Stopend Adjuster (code:603379) is to be limited to 250 mm as shown above, so that the locking bolt of the post can latch in the TOPMAX Stopend Angle (code:603375)



For illustration purposes, the assembly above uses timber planks as guardrails. However in some markets this method is not possible in which case PROTECTO (shown below) or EXTRAGUARD mesh panels can be used. All local regulations must be complied with.

Post without extension

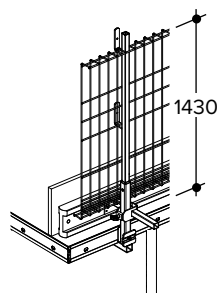

Post with extension 26

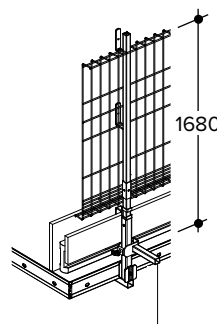

Post with extension 42

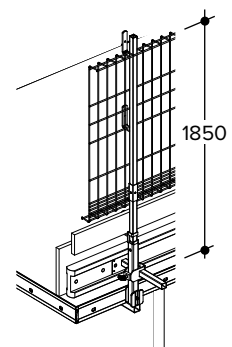

TOPMAX Stopend Angle maximum centres

Slab thickness [mm]	≤ 380	≤ 400	≤ 420	≤ 450	≤ 480	≤ 500
Distance of stopend angles [m]	1.80	---	0.90	---	---	0.60



For more information regarding edge protection, see page 65.

6 Table Transport

6.1 Multi Mover

The Multi Mover (code:607150) is an electrically driven trolley. It allows the lifting, adjusting, lowering and transportation of individual TOPMAX Floor Tables, which can be up to a maximum height of 7.50 m.

The Safe Working Load of the Multi Mover (code:607150) is 1,000 kg.

EUROPLUS^{new}, TOPMAX Extension Frames, GASS props, GASS shoring towers and a PROTECTO or an EXTRAGUARD edge protection may be added to the TOPMAX tables.



WARNING

Risk of serious injury!

If the Multi Mover (code:607150) is used to move tables with a height above 3.50 m without the outriggers extended, the floor tables can tilt. Always extend, the use of the outriggers is required and they must be secured with the bolts. The outriggers must be used fully extended when moving tables (see page 118).

The only exception occurs when moving 1.80 m wide tables in close proximity to the wall. The outrigger facing the wall where the table is to be placed can be partially retracted to an intermediate position to allow the table to be placed. Secure the outrigger with the bolt.



It may be possible to move TOPMAX tables with other attachments using the Multi Mover (code:607150) however this requires a separate structural analysis.



In all cases the Multi Mover (code:607150) must be positioned under the centre of gravity of the load to be carried. All loads must be evenly distributed.

Tables must be lowered as low as possible before moving.

Props must have a maximum floor clearance of 100 mm.



WARNING

Risk of overturning and serious injuries or death!

The operator has the responsibility to ensure safe operation/drive and must adjust/reduce speed as required depending on the evenness of ground surface, height and load. There is a significant safety risk of tilting the Multi Mover if the operator does not adjust/reduce speed according to each individual load case.

Overturning the Multi Mover can cause serious injuries or even death.

The operator must be trained to operated the equipment.



For more information regarding how to operate the Multi Mover (code:607150), including extending and retracting the telescopic arm (tower), please refer to the separate Operating Instructions. It can be found behind the lockable service cover of the Multi Mover (code:607150).

6.1.1 Overview

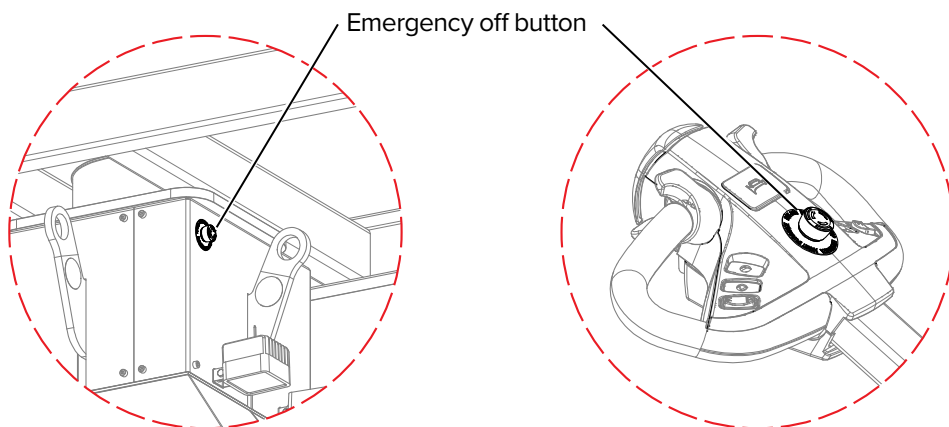
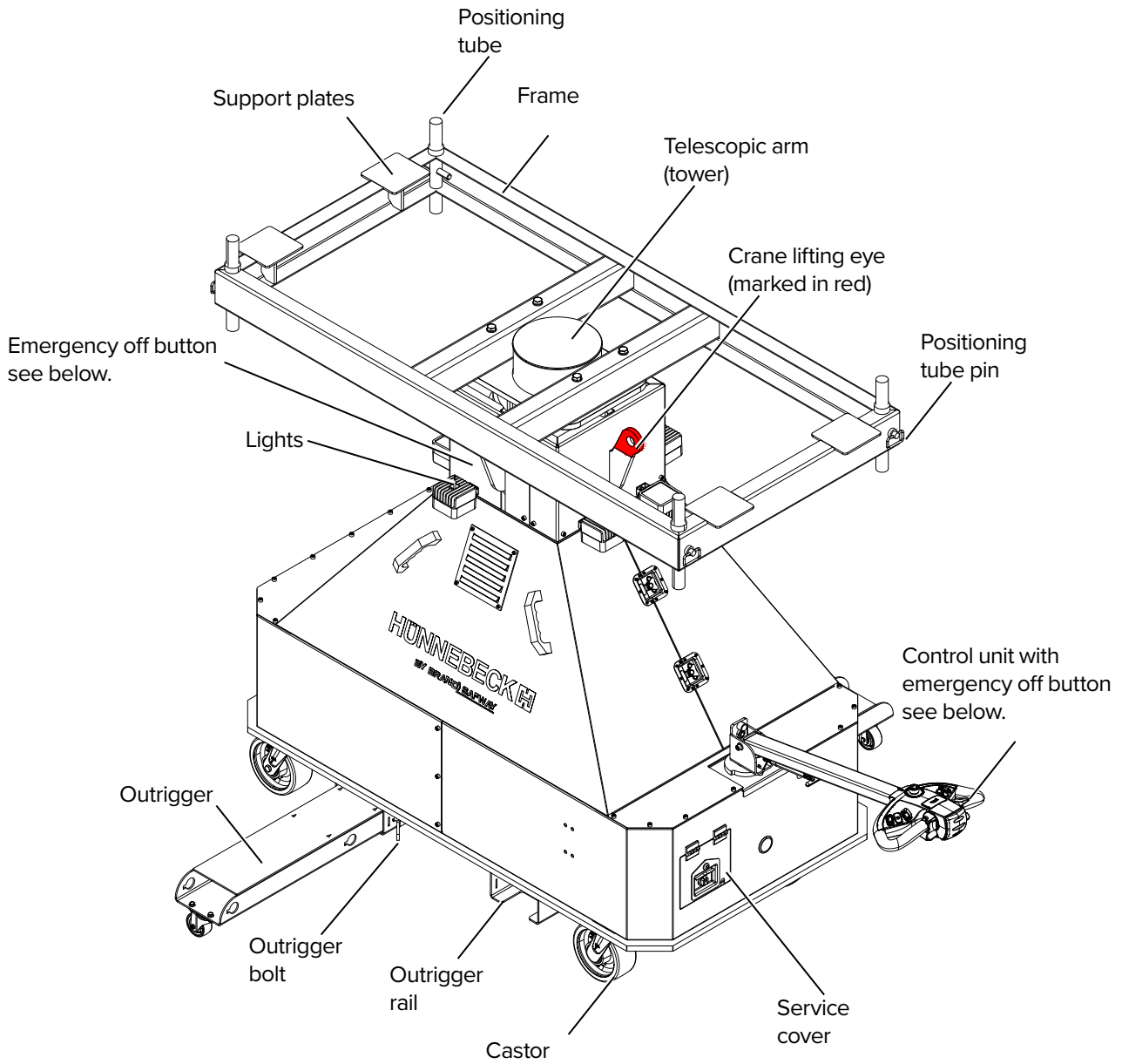

6.1.2 Lifting and transportation

Lifting by crane

Crane hooks with safety latches are only allowed to be hooked into the crane lifting eyes, marked in red, at the base of the telescopic arm (tower) of the Multi Mover (code:607150). For lifting by crane, all four crane eyes of the Multi Mover (code:607150) are to be connected with the lifting gear (use four-fold crane suspension).



The Working Load Limits of the lifting accessories must be observed and lifting and placing to be performed in controlled manner.

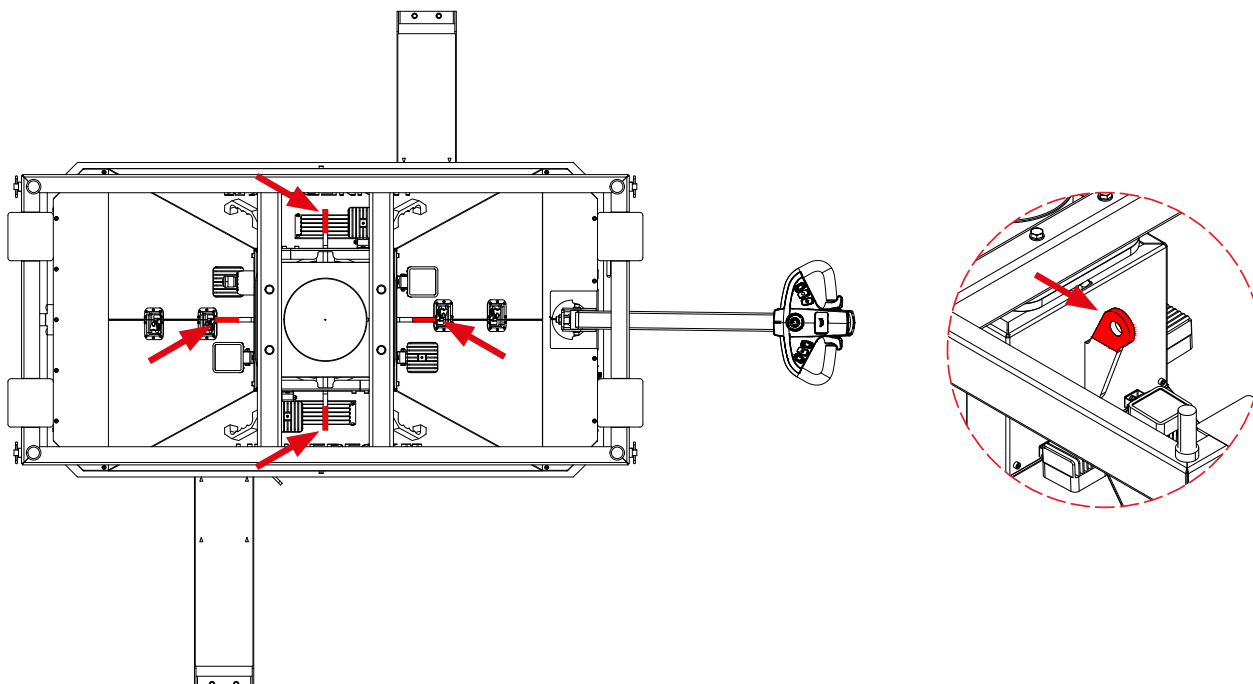

Transport by lorry



Lashing must only be carried out on the red crane lifting eyes (see image above). Housing parts must not be lashed. This may damage the housing and does not provide sufficient transport protection.

The outriggers must be transported in the fully retracted position and secured with the outrigger bolts.

Transport by forklift



The outriggers have to be removed (see page 118), so that the outrigger rails can be used as pockets for the forks.

The forks of the forklift must go into the outrigger rails when using a forklift to move the Multi Mover (code:607150). Both outrigger rails must be used by the forks. Do not use any other surface of the Multi Mover (code:607150) when using the forklift.

6.1.3 Use of the Multi Mover

The notes below must be followed when using the Multi Mover (code:607150):

- The Multi Mover (code:607150) must only be operated and maintained by competent persons.
- It is not allowed to operate the Multi Mover (code:607150) with any cover open.
- The Multi Mover (code:607150) must only be used if the operating instructions are present at the place of usage.
- It is not allowed to transport persons on the Multi Mover (code:607150).
- The Multi Mover (code:607150) must only be used on clean, free of debris solid and level base (e.g.: a dry concrete floor without ridges and edges, without open shafts for cables and pipe systems or overground cables, pipes and/or other material).
- The base must be flat. Driving with a load on an inclined surface is not allowed.
- The maximum manoeuvring speed without load in the normal direction (lengthwise) is 3 km/h and in the sidewise direction is 2 km/h.
- The manoeuvring speed with load must be reduced accordingly so that the Multi Mover (code:607150) does not tip to prevent the load from shifting.
- Any improper use is forbidden.
- Any changes or repairs to the Multi Mover (code:607150) without permission are forbidden.
- The Multi Mover (code:607150) must be submitted to a yearly check by an expert person. The check must be documented in writing and indicated on the Multi Mover (code:607150) with a test badge.

Documentation to be followed:

- TOPMAX User Guide from Hünnebeck.
- Relevant occupational safety and accident prevention regulations and standards.
- Operating instructions.
- Other local regulations / standards such as: VDMA Rules for operating companies of floor-level conveyors.

6.1.4 Operator's responsibility

The Multi Mover (code:607150) complies with the EC machinery directive and the approved safety-related regulations.

The Multi Mover (code:607150) must only be operated by the assigned and qualified persons.

6.1.5 Special duties and obligations of the operating company of the Multi Mover

- The operating company has to ensure that all staff members handling the Multi Mover (code:607150) have read and understood the operating instructions.
- The operating company is responsible for always keeping the Multi Mover (code:607150) in technically perfect and clean condition.
- The operating company has to take care that the maintenance intervals described in the operating instructions are met.
- The operating company is obliged to have regularly checked the operative readiness and integrity of all safety devices.
- The operating company has to ensure that all warnings and information listed in the operating instructions are observed.

- The operating company has to appoint staff members supervising the compliance with safety, accident prevention and environmental regulations in the area of use of the Multi Mover (code:607150).
- The operating company must regularly train the employees dealing with the Multi Mover (code:607150), provide information about regulations and risks, and to punish infringement of the regulations.
- The operating company must clearly structure and define the responsibilities regarding operation, maintenance, check, repair and servicing of the Multi Mover (code:607150).
- The operating company must obtain information on the valid industrial safety regulations, and to determine by means of risk assessment the additional risks resulting from the special working conditions at the operating site of the Multi Mover (code:607150). These must be converted into operating instructions for operating the Multi Mover.
- During the entire time of application of the Multi Mover (code:607150), the operating company has to ensure that the all requirements of the operating instructions and of this product information are met.

6.1.6 Permit for commissioning and operation

Commissioning and operation of the Multi Mover (code:607150) is only allowed to assigned and qualified persons sufficiently instructed in the operation of the electrical lifting trolley, who have read and understood the operating manual, and know and observe all other applicable regulations.

The training given have to include the following:

- Knowledge of the content of the operating manual and of the product information to ensure a qualified operation of the Multi Mover (code:607150).
- Knowledge and execution of specifications and regulation resulting from all other applicable regulations for operating the Multi Mover (code:607150).
- A list of suitably qualified persons must be available. It should contain the names and signatures of the qualified employees and the date of the training. The list should be kept by the operating company and can be consulted upon request.

6.1.7 Permit for maintenance of the Multi Mover and intervention in the vehicle

Only trained and qualified personnel are allowed to carry out maintenance and interventions in the Multi Mover (code:607150). They should meet the following requirements:

- Specialist for maintenance and check

Due to technical training, knowledge and experience, and knowledge of the relevant provisions is capable to execute the works of maintenance and check on the Multi Mover (code:607150) delegated to him, and to independently recognise and avoid possible risks.

- Professional electrician

Has the ability because of their technical training and experience, as well as knowledge of the relevant standards and provisions, to carry out works on electrical installations, and to independently recognise and avoid possible risks.

- Specialists for repairs (servicing)

Because of their technical training, advanced knowledge and experience, as well as awareness of the relevant provisions, they are able to carry out the assigned repair works on the Multi Mover (code:607150), and to independently recognise and avoid possible risks.

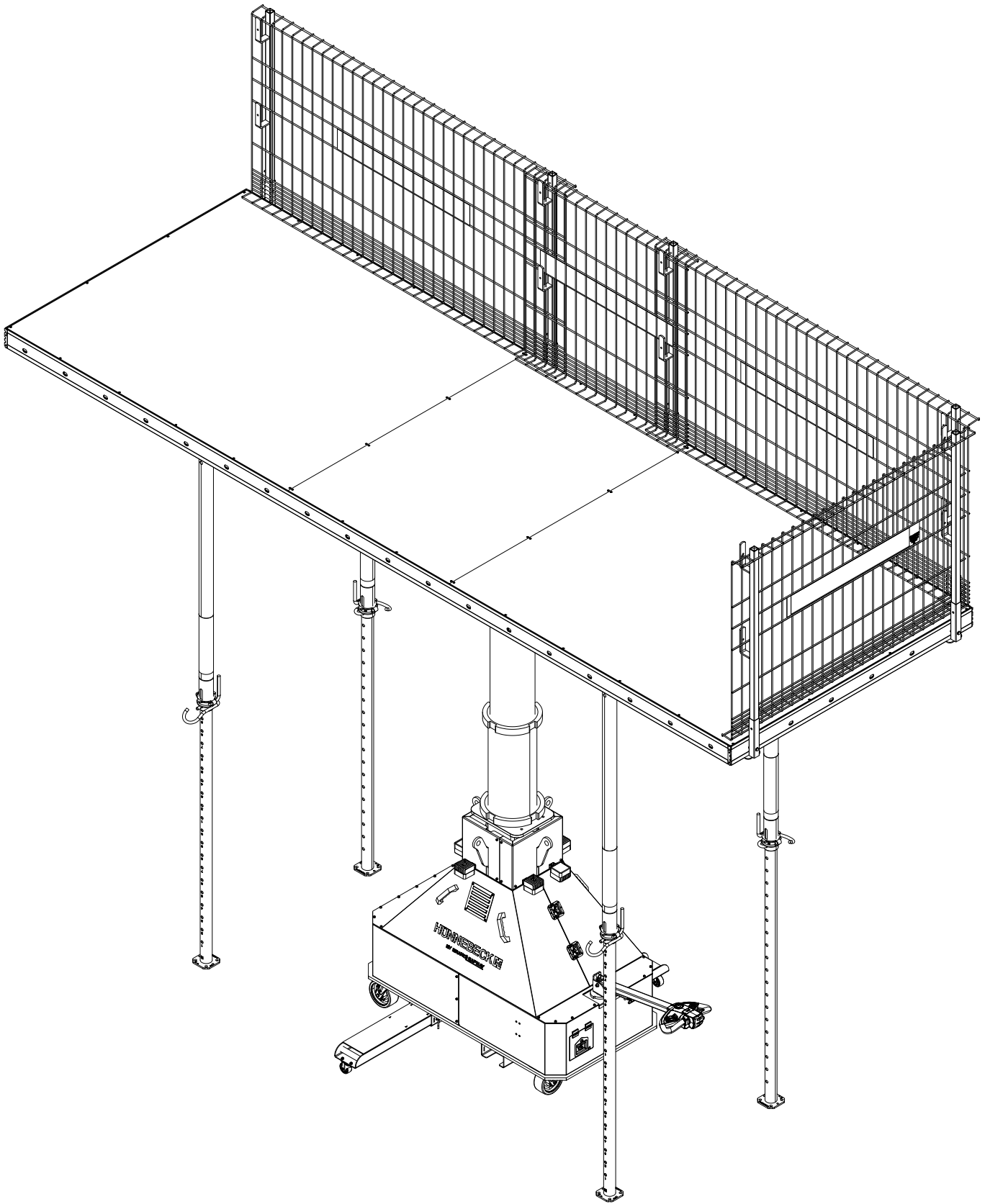

6.1.8 Minimum and maximum heights

The Multi Mover (code:607150) can move tables with a maximum table height of 4.50 m without the Multi Mover Extension Frames (code:607152). With the TOPMAX Extension Frames (code:603479) or the Multi Mover Extension Frames (code:607152) the Multi Mover (code:607150) can move tables with a maximum height of 7.50 m. The Multi Mover Extension Frame (code:603479) provides a height extension of 1.00m as shown below.

**Multi Mover
without
Multi Mover
Extension Frame**

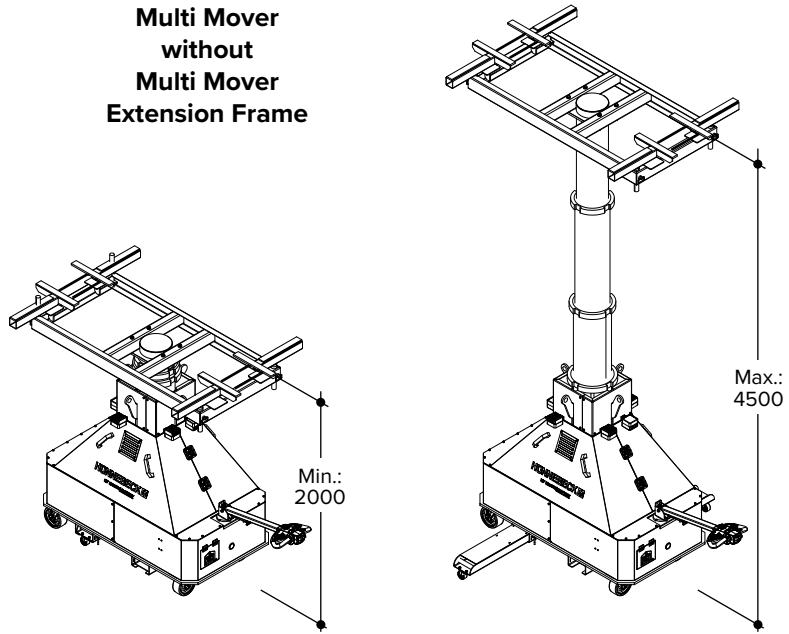

**Multi Mover
with
Multi Mover
Extension Frame**

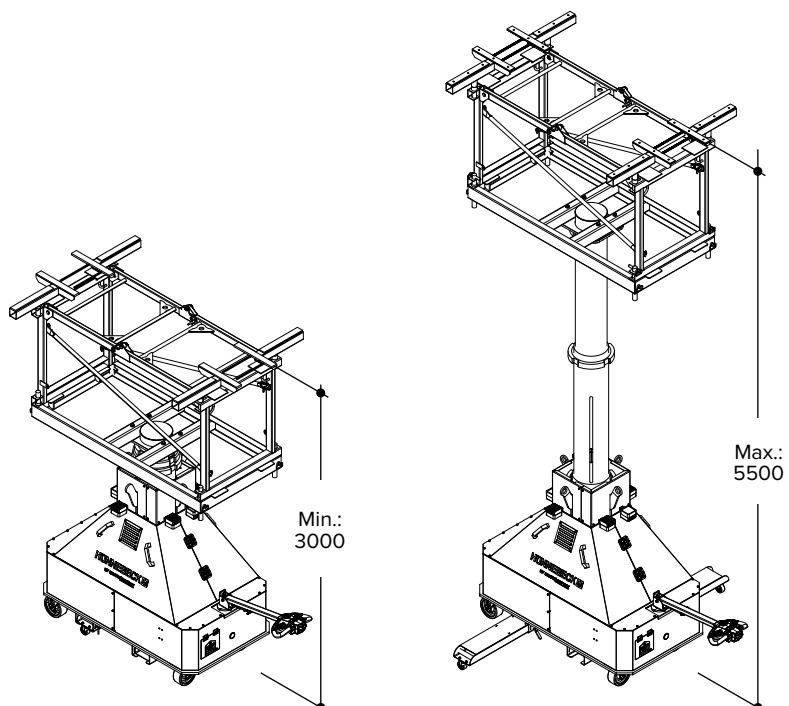

6.1.9 Operating the Outriggers

The outriggers are a part of the Multi Mover (code:607150) and must be extended when moving TOPMAX tables higher than 3.50 m.

The outriggers are used to prevent the Multi Mover (code:607150) from tilting. There are 2 no. positions to which the outriggers can be extended, fully extended or slightly retracted from the maximum extension. Whilst transporting tables, the outriggers must always be in the fully extended position. The second position, slightly retracted, allows the table to be placed close to a wall and can only be used with the 1.80 m wide tables.

The outriggers are secured using the handle bolt located on the outrigger rails.



Operating the Multi Mover (code:607150) with the outriggers extended requires a very level and clean ground due to the reduced ground clearance.

The support wheels of the outriggers do not touch the ground. This only happens when the Multi Mover (code:607150) is at risk of overturning.

Step 1 Turn the handle bolt as shown below.

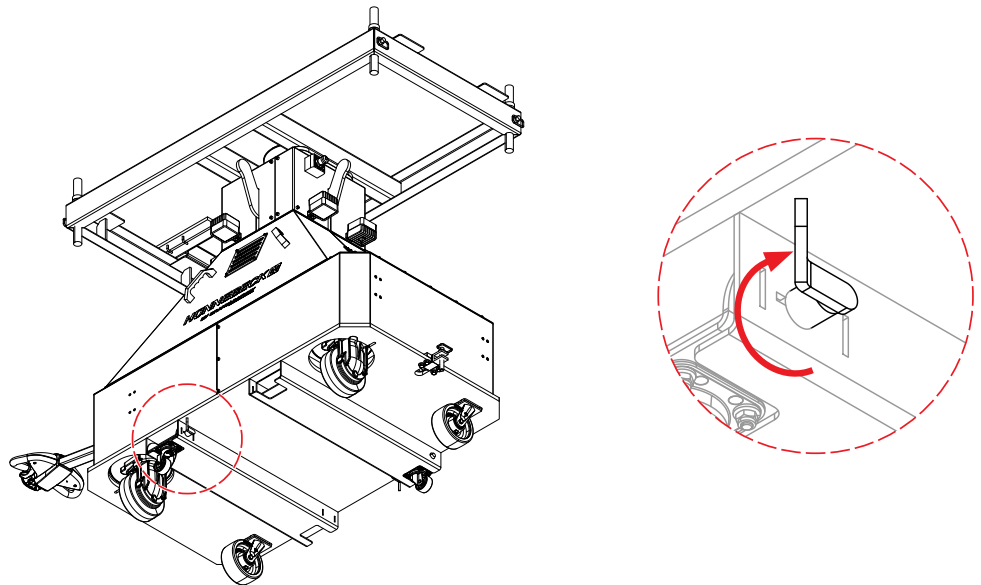

Step 2 Pull the bolt out and keep it for later use.

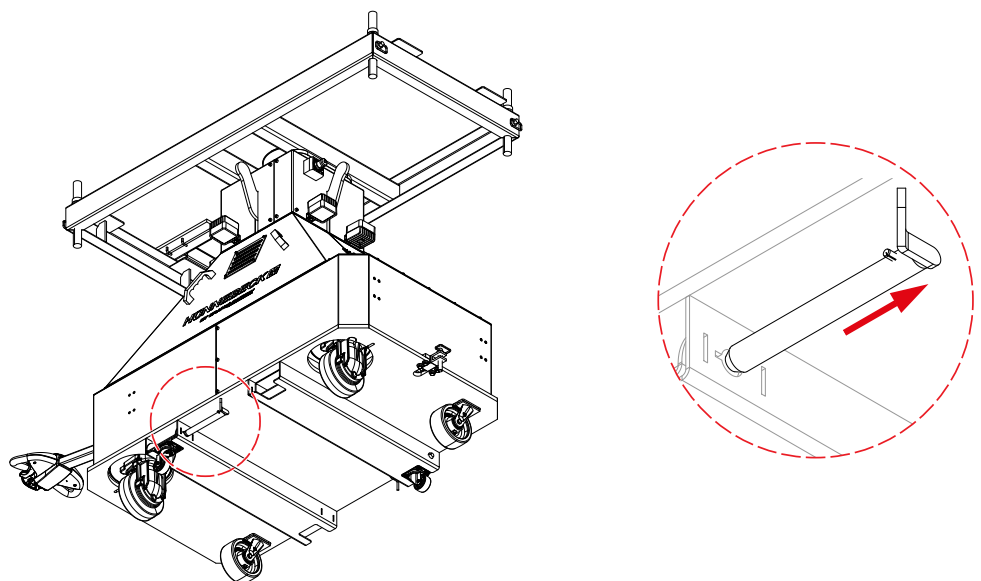

Step 3 Slide the outriggers out to the required position.

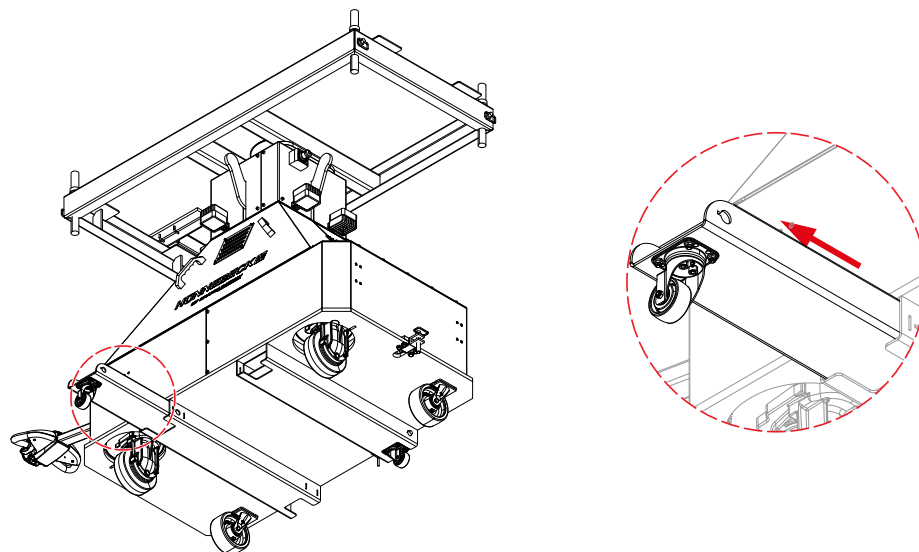

Step 4 Align the hole positions of the outriggers with the hole of the rails, see warning on page 111.

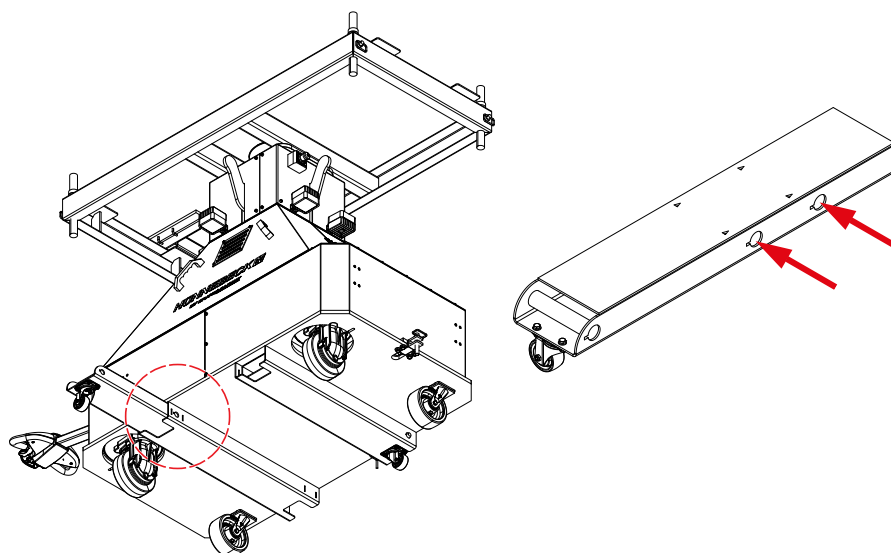

Step 5 To secure the outrigger insert the bolt into the hole position on the rail and turn the handle bolt.

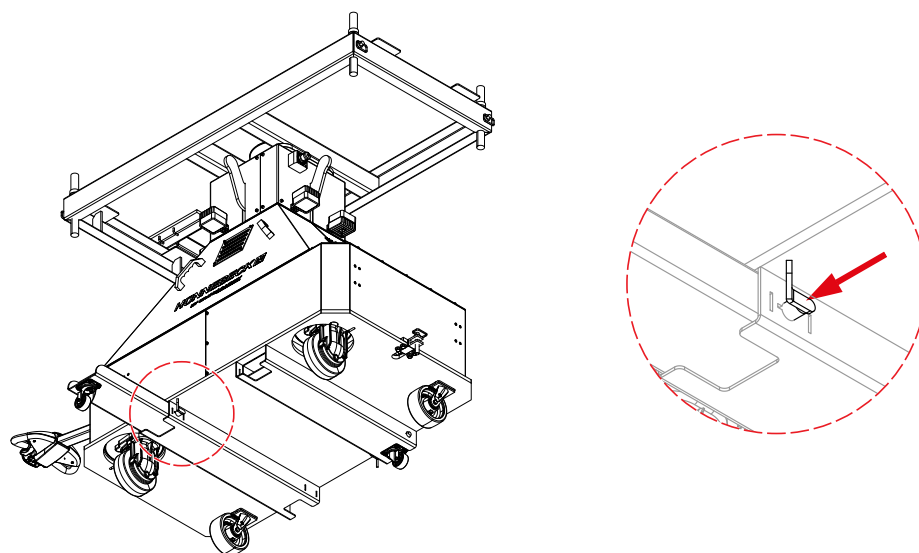

Step 6 Turn the bolt to secure the outrigger.

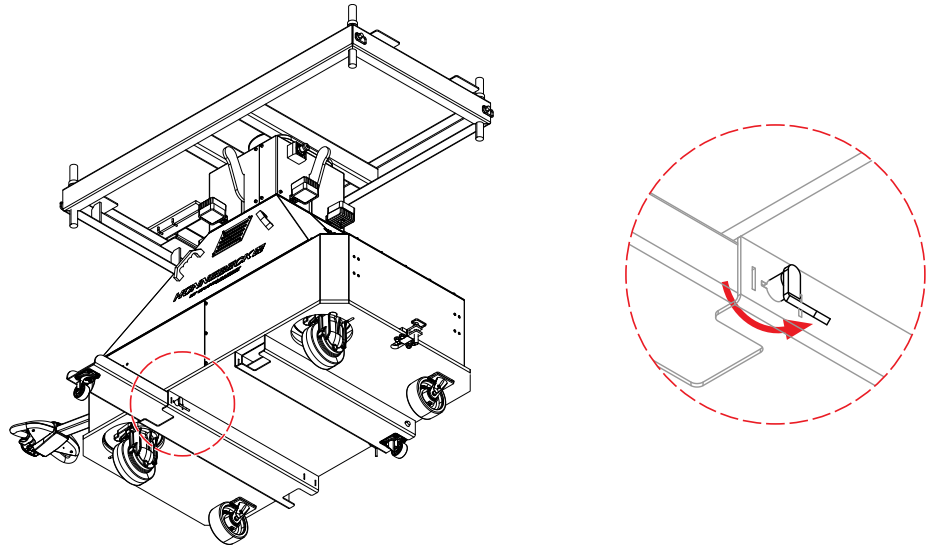

Step 7 Repeat steps 1–6 for the other outrigger.

To remove the outriggers (for transportation by forklift truck for example), follow steps 1–2, remove the outriggers and place the bolt into the outrigger.

6.1.10 Attaching the TOPMAX Turning Heads

A set of 4no. TOPMAX Turning Heads with 4no Readjusting Springs (code:607160) are used for lifting TOPMAX Floor Tables.

If TOPMAX Floor Tables with beams mounted underneath, e.g. TOPMAX Support Girders (code:603390), the height of the turning heads on the Multi Mover (code:607150) can be extended to 220 mm (see below).

The tube allows for the head to be positioned in two height positions as shown below.

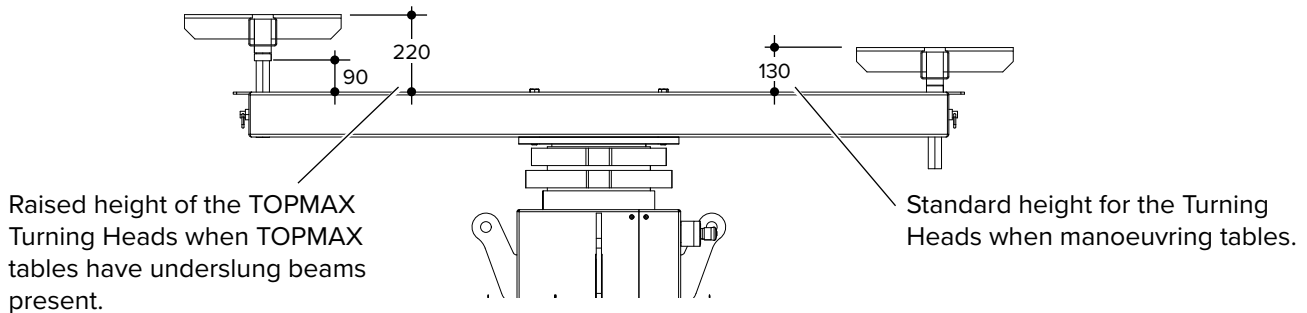

A suitable method for work at height must be provided, i.e. scaffold, Mobile Elevating Work Platforms (MEWP), etc., so that all operations can be performed from a safe working platform. Do not stand on the Multi Mover (code:607150).

Step 1 Remove the locking pin located on the frame.

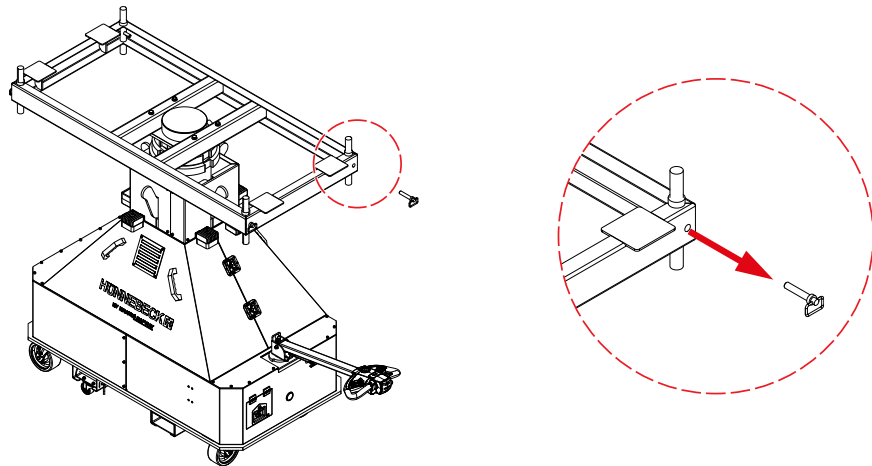

Step 2 Adjust the height of the positioning tube.

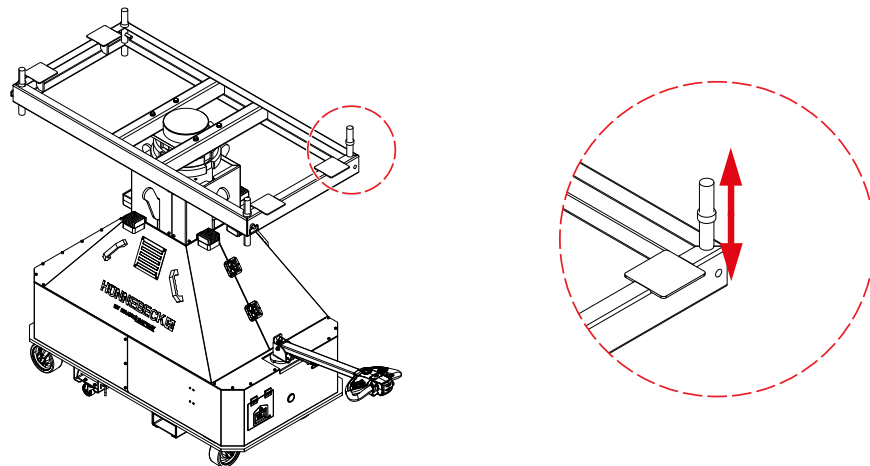

Step 3 Align the hole position on the tube with the hole position of the frame and re-insert the locking pin in the original hole position.

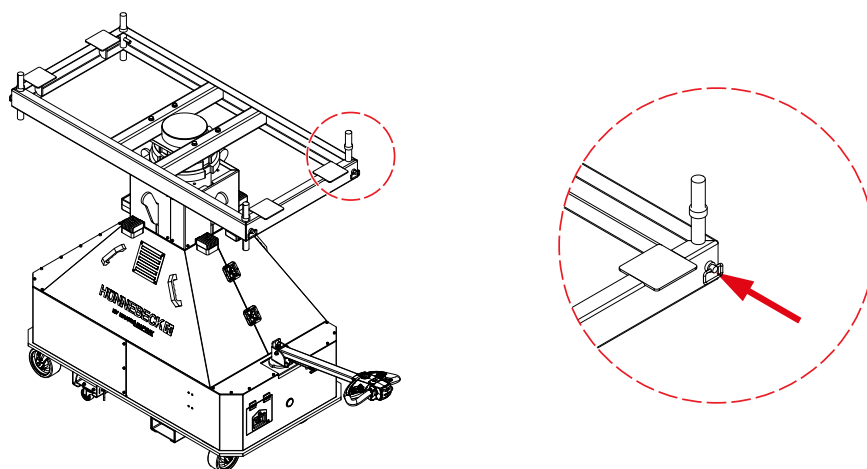

- Step 4** Attach the head by inserting the sleeve on the bottom of the head into the positioning tube.

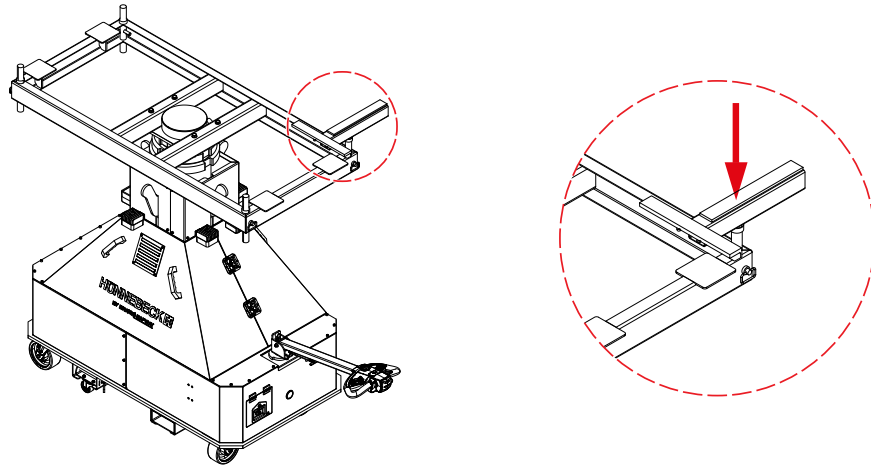

- Step 5** Repeat steps 1–4 for the opposite side or only step 4 if height doesn't need to be adjusted.

- Step 6** Secure opposing heads by attaching 2no. Readjusting Springs (code:603303) into the eyes under the top plate of the heads.

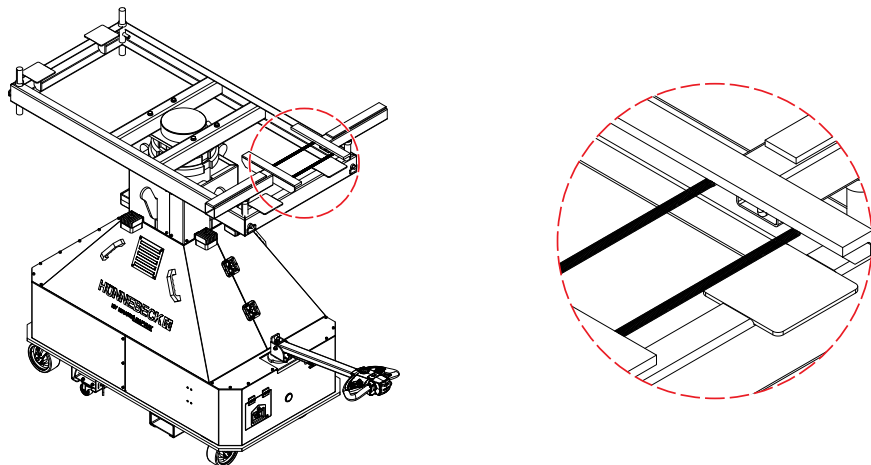

- Step 7** Repeat steps 1–6 for the other side of the Multi Mover (code:607150) frame.

6.1.11 Attaching the Multi Mover Extension Frames

A removable Multi Mover Extension Frame (code:607152) is available for the Multi Mover (code:607150) for the purpose of transporting TOPMAX Floor Tables of greater height. The Multi Mover Extension Frame (code:607152) remains firmly connected to the Multi Mover (code:607150) during operation.



A suitable method for work at height must be provided, i.e. scaffold, Mobile Elevating Work Platforms (MEWP), etc., so that all operations can be performed from a safe working platform. Do not stand on the Multi Mover (code:607150) .

If the TOPMAX Turning Heads (code:603237) are installed on the Multi Mover (code:607150) they must be removed before assembly of the extension frames. To do so repeat the turning heads assembly process in the reverse order (see page 120) until all heads are removed.

Next the Multi Mover Extension Frame (code:607152) must be extended and braced before being assembled onto the Multi Mover (code:607150).

Step 1 Attach the crane hooks with safety latches to the Multi Mover Extension Frame (code:607152) using the attachment points as shown. Move the Multi Mover Extension Frame (code:607152) to the ground with the help of a crane.

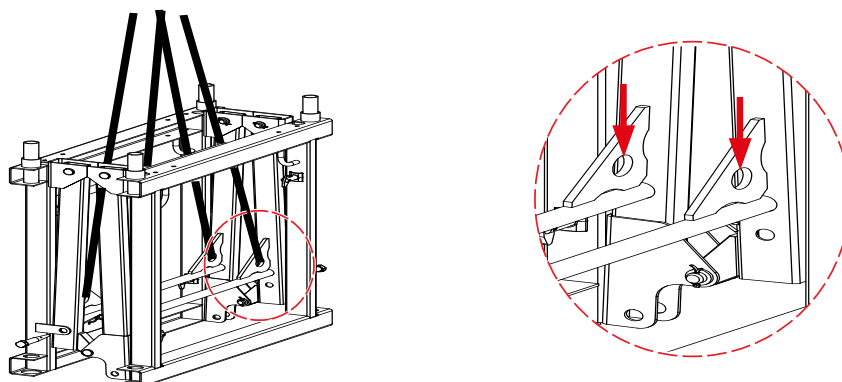

Step 2 Once the frame is on the ground, remove both locking bolts and spring pins. Keep them for later use.

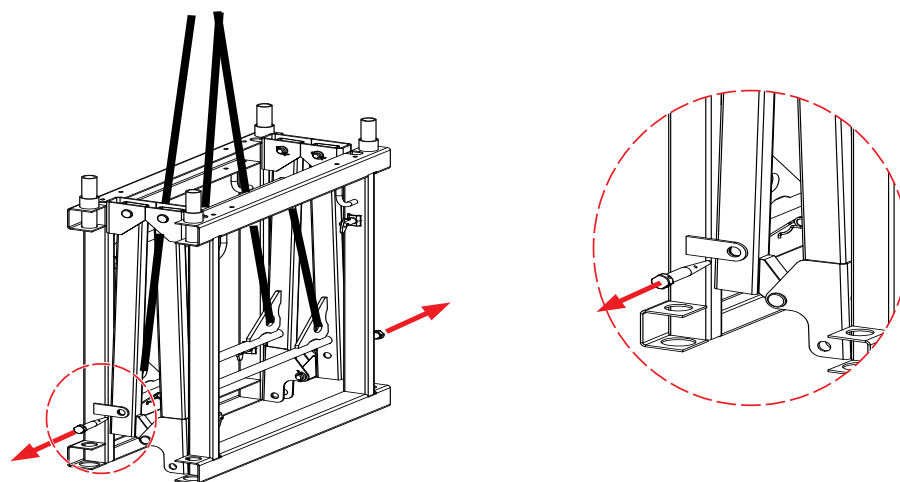

Step 3 Whilst the Multi Mover Extension Frame (code:607152) is pulled upwards by the crane, pull the frame open by hand.

CAUTION

Risk of crushing!

Operatives must wear gloves and take care not to allow any extremities (hands and fingers for example) to be caught by the swivel parts of the frame.

It is recommended that this operation is done by at least two people.

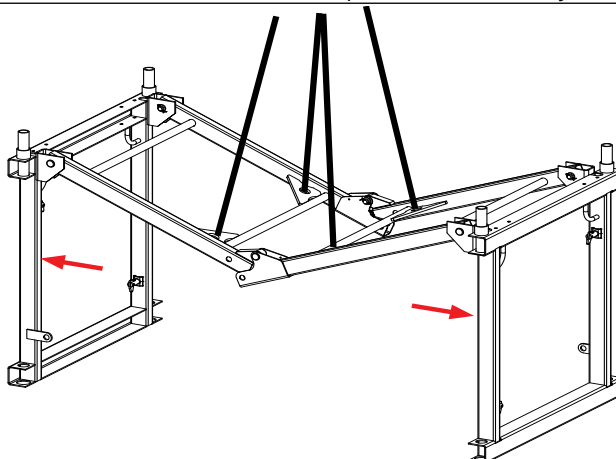

- Step 4** Fully open the extension frame and secure the hinge on each side with the locking bolts and spring pins.

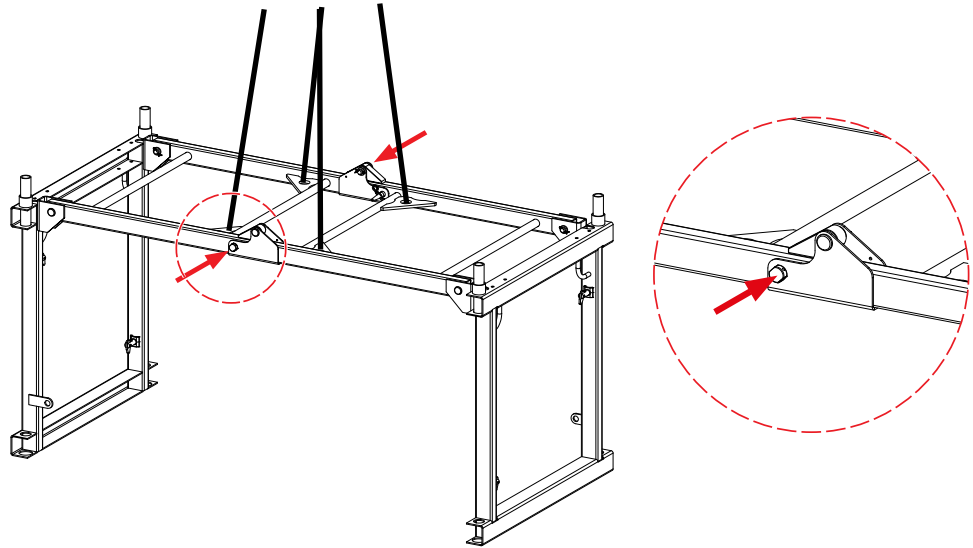

- Step 5** Attach the Guardrail 200 (code:154080) braces to the anti-luce fittings. The braces are ordered separately.

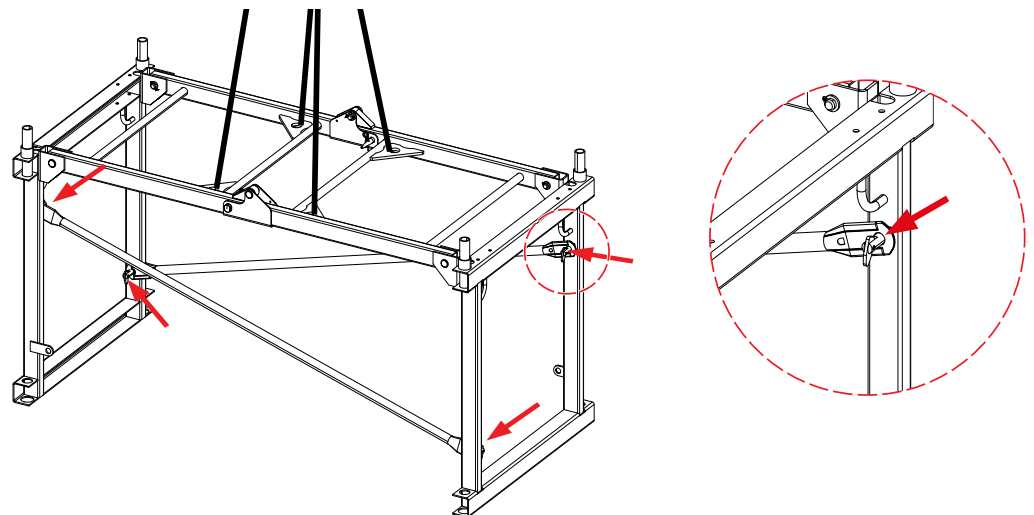

- Step 6** The crane slings can be released after the frame is securely fastened.

- Step 7** Attach the TOPMAX Turning Heads (code:603237) in similar way as the Multi Mover Extension Frame (code:607152).

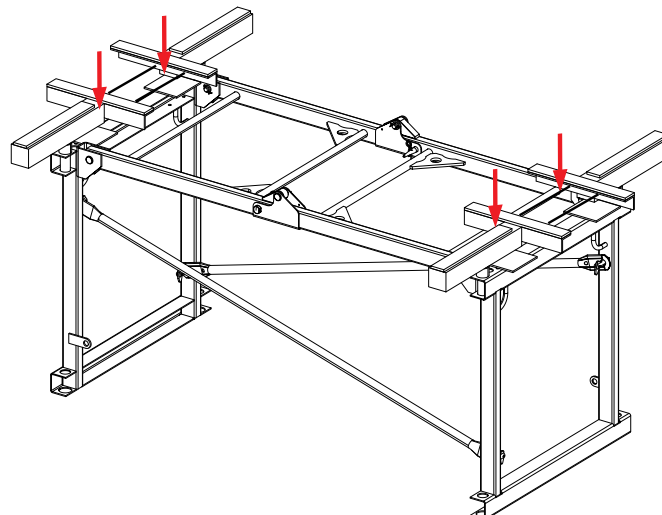

Step 8 Attach the crane slings to the outer attachment points located on the top corners of the frame.

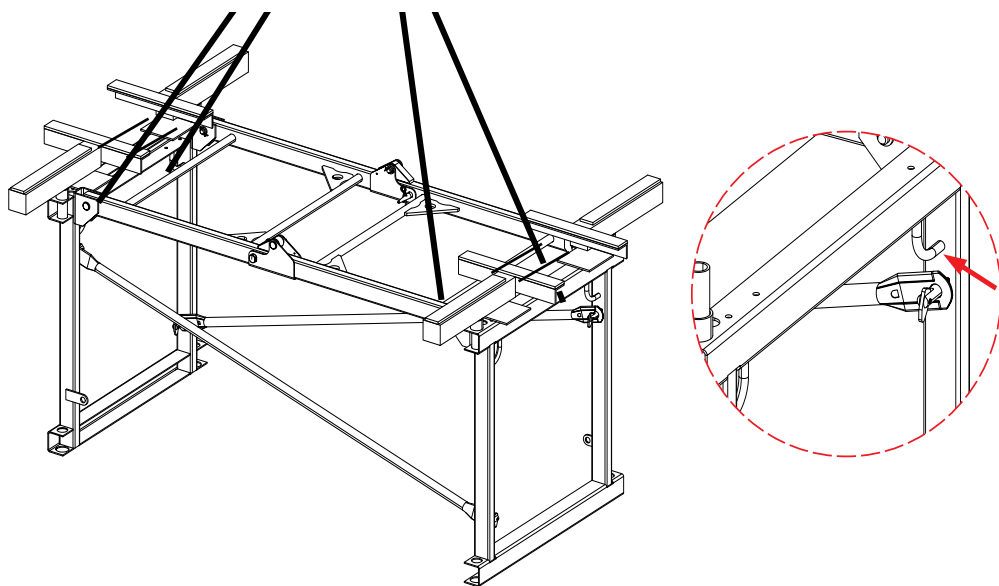

Step 9 Lift the frame into the connecting pins on top of the Multi Mover (code:607150) and secure using the Multi Mover Locking Pins (code:607156), R-safety clips not shown, at the bottom corners. The pins are ordered separately.



The Multi Mover (code:607150) telescopic arm (tower) must be in its most retracted position. See also warning on page 111 regarding the outriggers.

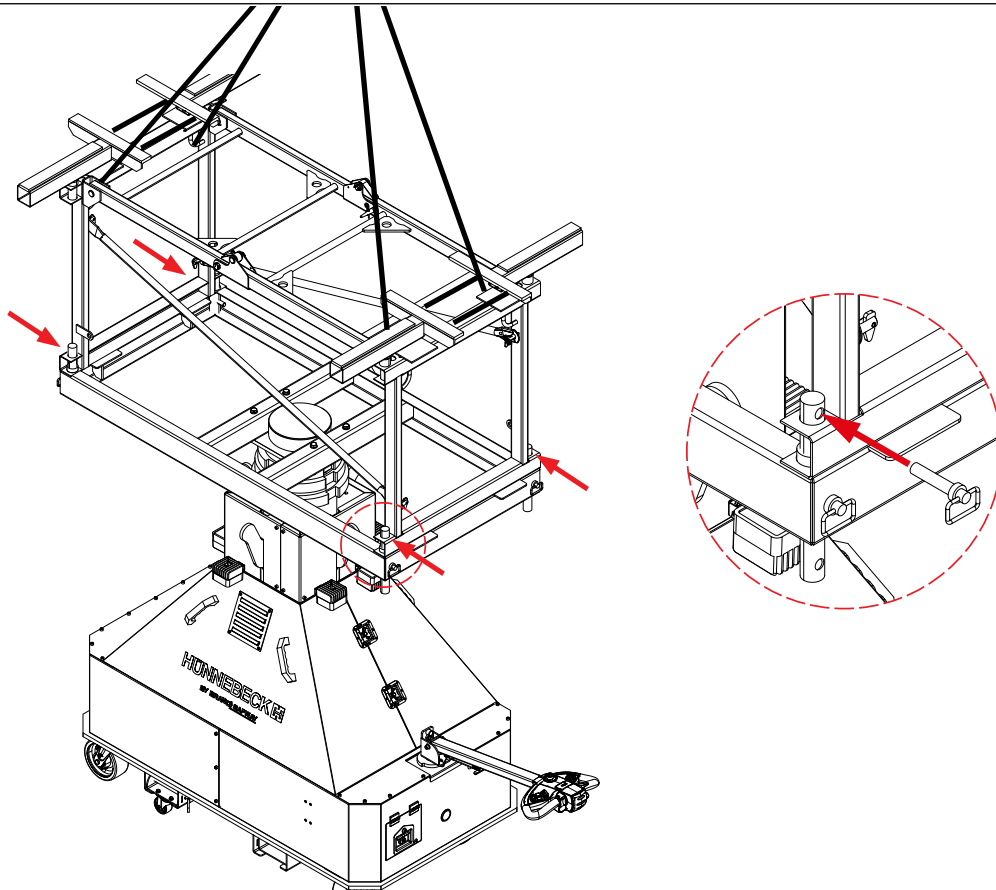

Ensure that all connections are secure and that all bolts and safety pins are securely fastened before releasing the slings.

6.1.12 Lifting and moving floor tables



WARNING

Risk of overturning!

Fast movements of the control unit and careless driving, especially in curves, can cause floor tables and the Multi Mover (code:607150) to overturn.

This can result in serious injury or death.

Ensure that, if possible, no persons are present in the danger zone.

Drive very carefully.

Drive particularly slow in curves.

Pay attention to the load and counteract if necessary.

In case of danger, stop and set down the load.

Lifting and moving TOPMAX Floor Tables with EUROPLUSnew Props

Tables with and without mounted TOPMAX Extension Frames (code:603479) can be moved with the Multi Mover (code:607150).

Floor tables without the TOPMAX Extension Frames (code:603479) must be lifted using the mounted TOPMAX Turning Heads (code:603237) and Readjusting Springs (code:603303).

For the maximum table height allowed to be moved see page 129.

Lifting and moving TOPMAX Floor Tables with TOPMAX Extension Frame

Floor tables with the TOPMAX Extension Frame (code:603479) must be supported by H 20 beams 3.90 m long.

If turning heads have been assembled beforehand on the Multi Mover (code:607150) frame, first disassemble these. To do so, repeat the turning heads assembly process in the reverse order (see page 120) until all heads are removed.

For the maximum table height allowed to be moved see page 129.

- Step 1** Place 2no. H 20 Beams (code:581829) on top of the support plates of the frame as shown below.
- Step 2** Secure the beams to all support plates using 4no. H 20 Beam Clamps (code:568048).
- Step 3** Attach 2no. Joist Clamping Connectors (code:496469) to each H20 Beam so that the extension frame can be placed in-between the clamps.

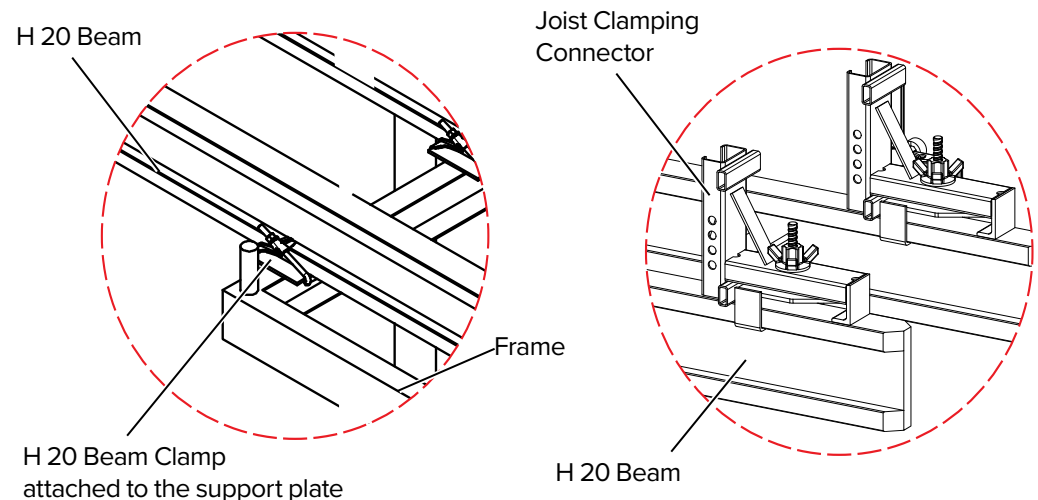

Ensure that the position of the Joist Clamping Connectors (code:496469) is such that the load to be lifted can be located centrally on the lifting equipment.

Step 4 Move the Multi Mover (code:607150) under the centre of gravity of the table.

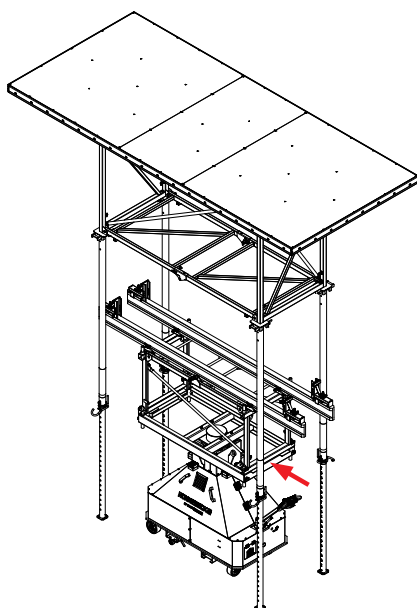

Step 5 Extend the outriggers, see page 118.

Step 6 Extend the telescopic arm (tower) until the extension frame is supported.

! WARNING

Risk of damage, collapse and/or serious injury!
 Ensure that the H 20 Beams are positioned under the TOPMAX Extension Frame (code:603479) profile and are not resting on other components! Risk of overturning.



For more information regarding how to operate the Multi Mover (code:607150), including extending and retracting the telescopic arm (tower), please refer to the separate Operating Instructions.

Step 7 Lift and move the TOPMAX table.

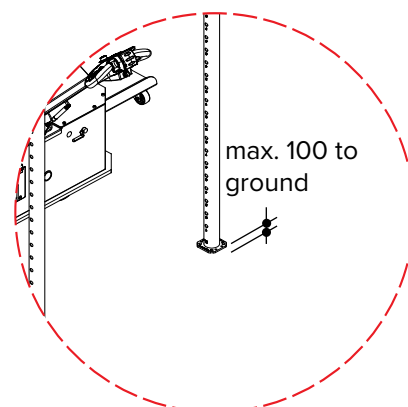
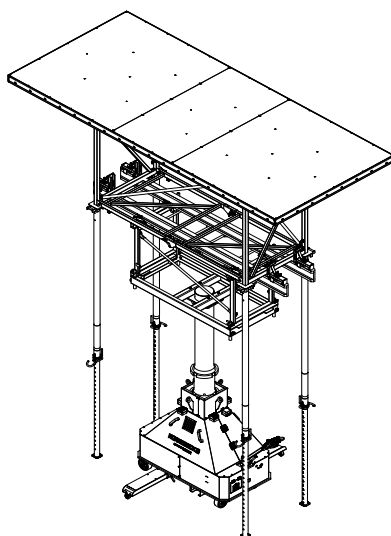

Tables must be lowered as low as possible before moving. Props must have a maximum floor clearance of 100 mm.

! WARNING

Risk of damage, collapse and/or serious injury!
 To avoid overturning the maximum height that is allowable to be moved using the Multi Mover (code:607150) is 7.50 m. Do not stack the TOPMAX Extension Frame with more than one Multi Mover Extension Frame.

Lifting and moving TOPMAX Floor Tables with GASS Props

When moving TOPMAX tables with GASS props, H 20 Beams must be attached to the Multi Mover (code:607150) frame or to the top Multi Mover Extension Frame (code:607152). The procedure for this is identical to that for the transportation of tables with TOPMAX Extension Frames (code:603479), see page 126.



GASS Tables to be used when the maximum capacity of the EUROPLUSnew is exceeded.

When installing the GASS props and frames, the minimum height of the Multi Mover (code:607150) must be considered (see page 117):

- Without Multi Mover Extension Frames (code:607152): minimum 2.00 m;
- With Multi Mover Extension Frames (code:607152): minimum 3.00 m.

The frames must be mounted in such a way that the Multi Mover (code:607150) with mounted H 20 Beams can be moved underneath the table. A 50 mm minimum clearance should be considered. It might be required to remove the lower GASS Frames in order to provide access and operate the Multi Mover (code:607150).

The GASS frames on which the Multi Mover (code:607150) picks up the system must be at the same height and well tightened.

For the maximum table height allowed to be moved see page 129.

NOTICE

Risk of damage to components!

If single GASS Legs are used with the TOPMAX Floor Tables, the legs must not be swung when moving the table and must remain in the vertical position at all times.



WARNING

Risk of overturning and serious injuries or death!

To avoid overturning the maximum height that is allowable to be moved using the Multi Mover (code:607150) is 7.50 m. Do not exceed the SWL of the Multi Mover (code:607150), see page 111.

6.1.13 Table configurations

Some possible table configurations and height restrictions are as follows:

Configuration 1 - Max. Height: 7.50 m

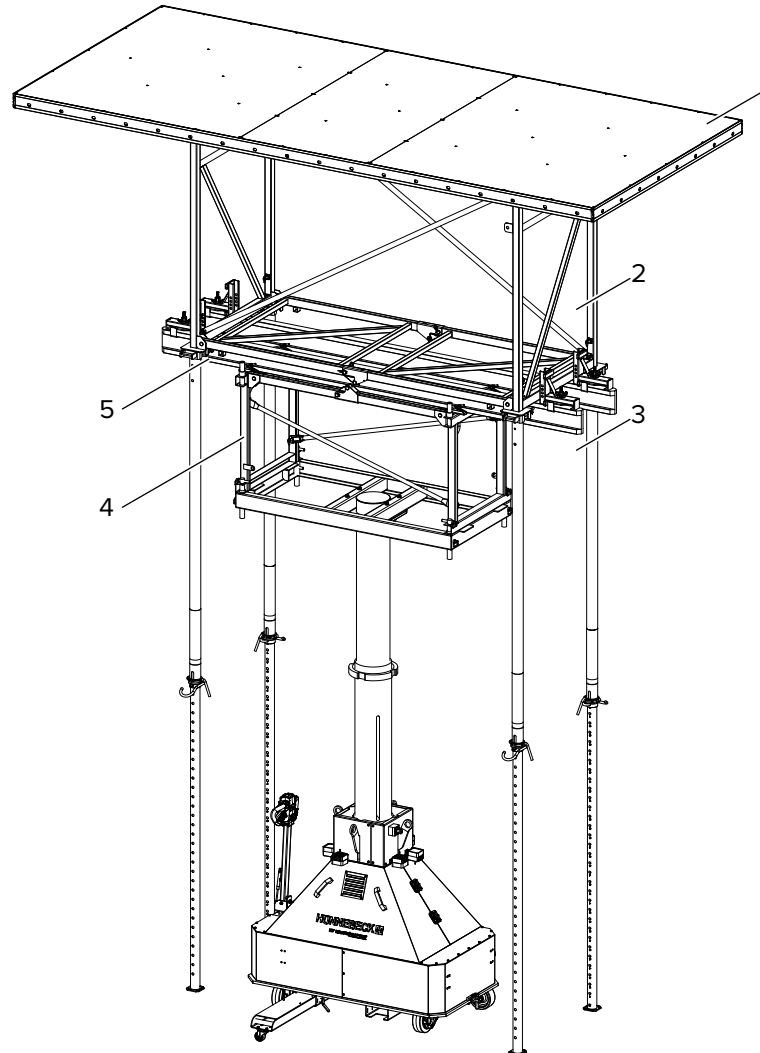

1. TOPMAX Floor Table 2.4 x 5.4 m (code:602586)
2. TOPMAX Extension Frame (code:603479)
3. EUROPLUSnew 20/550 (code:601425)
4. Multi Mover Extension Frame (code:607152)
5. H20 Beams 3.90 m (code:581829)

Configuration 2 - Max. Height: 5.50 m

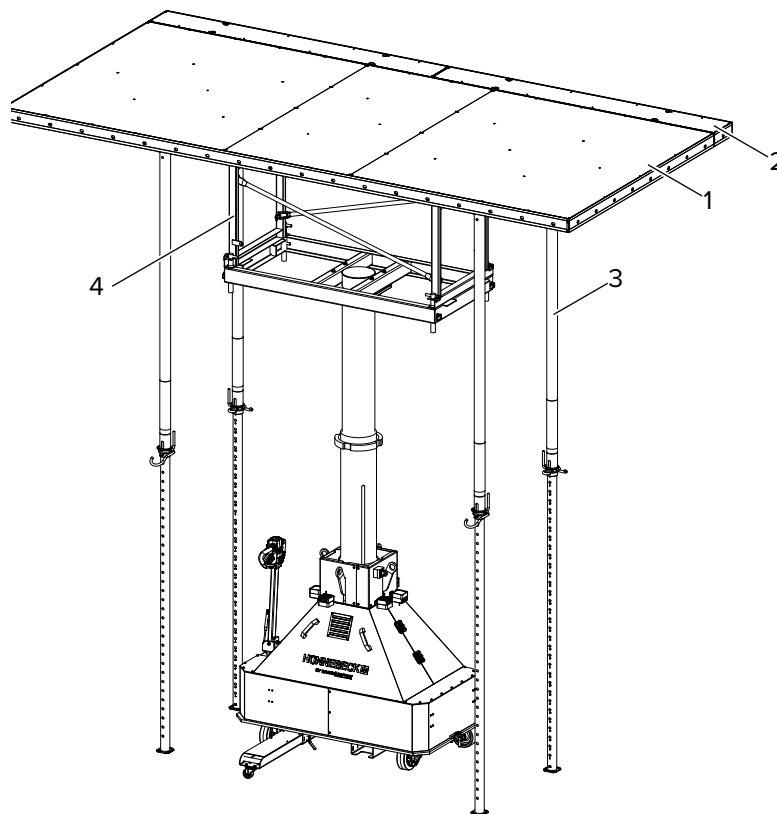

1. TOPMAX Floor Table 2.4 x 5.4 m (code:602586)
2. RASTO Panels (300 mm wide) *
3. EUROPLUSnew 20/550 (code:601425)
4. Multi Mover Extension Frame (code:607152) with Turning Heads (code:607160)



* - Do not exceed the stated width.
For the connection of RASTO Panels to TOPMAX Floor Table see page 51.



For more information regarding the RASTO system, please refer to the current User Guide.

Configuration 3 - Max. Height: 3.50 m

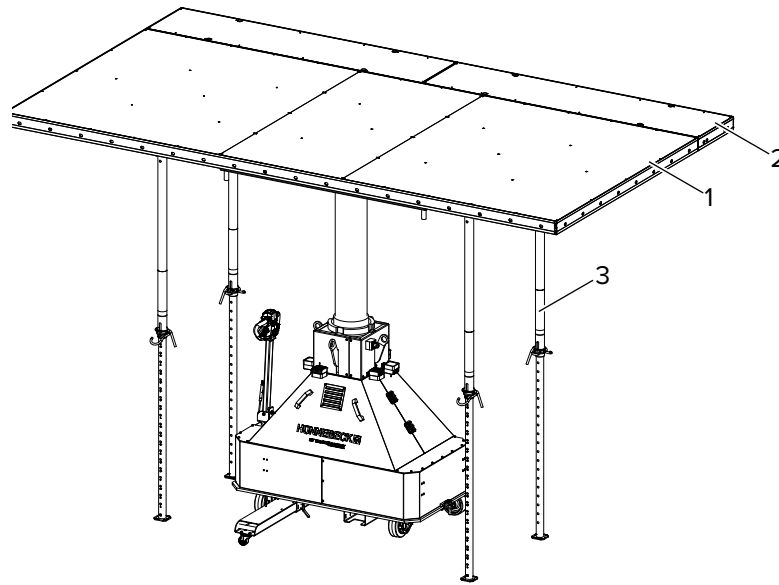

1. TOPMAX Floor Table 2.4 x 5.4 m (code:602586)
2. RASTO Panels (600 mm wide) *
3. EUROPLUS^{new} 30/350 (code:601445)



* - Do not exceed the stated width.
For the connection of RASTO Panels to TOPMAX Floor Table see page 51.

** - Multi Mover with Turning Heads (not visible)



For more information regarding the RASTO system, please refer to the current User Guide.

Configuration 4A - Max. Height: 7.50 m

The GASS Leg make-up shown below allows for a maximum table height of 7.90 m, however the table must not exceed a height of 7.50 m when being moved.

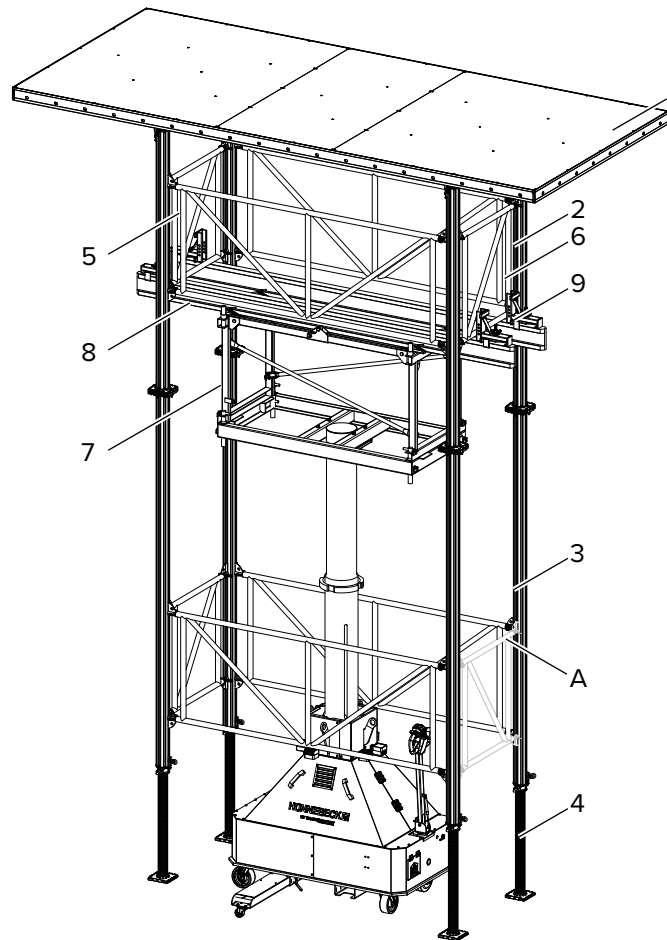

1. TOPMAX Floor Table 2.4 x 5.4 m (code:602586)
2. GASS Extension Leg 2490 mm (code:718009)
3. GASS Leg 3580 mm (code:718003) *
4. GASS Inner Leg 1450 mm (code:718014)
5. GASS Ledger Frame 3.0 m (code:718023)
6. GASS Ledger Frame 1.2 m (code:718020)
7. Multi Mover Extension Frame (code:607152)
8. H20 Beams 3.90 m (code:581829)
9. Joist Clamping Connector (code:496469)

* - A program to retrofit existing GASS outer legs with the double latch arrangement is underway, during this retrofit period both single and double latch outer legs will be in our stocks. Both options are interchangeable however the separate Safety Latch (code:718907) must be used on all single latch legs when lifting or flying.

A - Before moving the table, the GASS Ledger Frame 1.2 m (code:718020) must be temporarily removed to allow for the arm of the Multi Mover to be operated.



For more information regarding the GASS system including the maximum capacity of the GASS towers, please refer to the current User Guide.

Configuration 5 - Max. Height: 6.50 m

The GASS Leg make-up shown below allows for a maximum table height of 7.90 m, however the table must not exceed a height of 6.50 m when being moved.

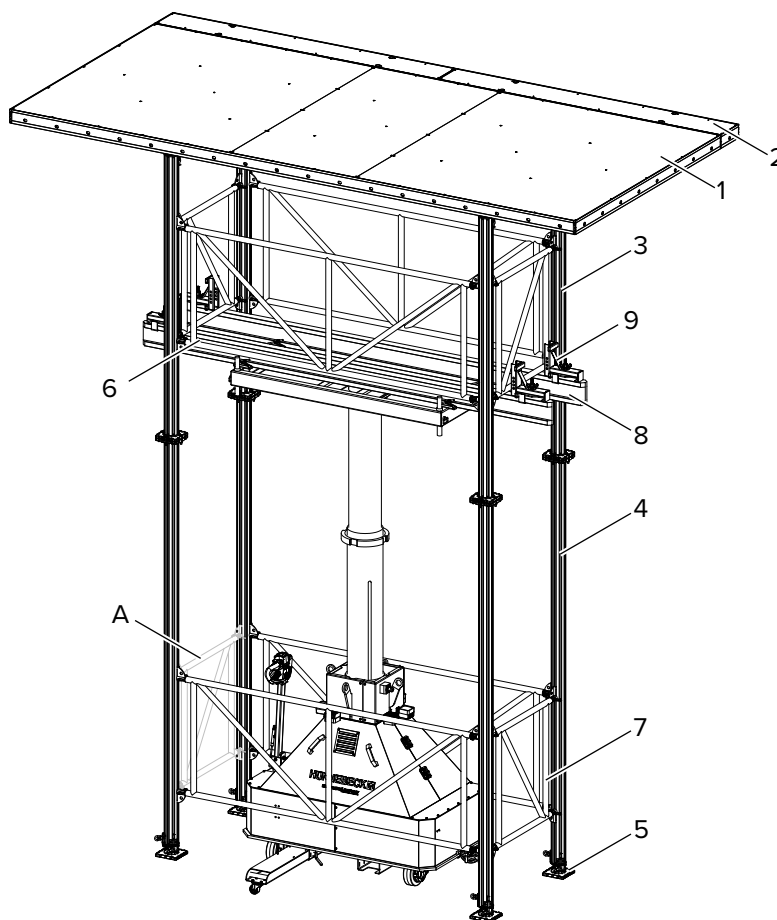

1. TOPMAX Floor Table 2.4 x 5.4 m (code:602586)
2. RASTO Panels (300 mm wide) *
3. GASS Extension Leg 2490 mm (code:718009)
4. GASS Leg 3580 mm (code:718003) **
5. GASS Inner Leg 1450 mm (code:718014)
6. GASS Ledger Frame 3.0 m (code:718023)
7. GASS Ledger Frame 1.2 m (code:718020)
8. H20 Beams 3.60 m (code:581818)
9. Joist Clamping Connector (code:496469)



* - Do not exceed the stated width.

For the connection of RASTO Panels to TOPMAX Floor Table see page 51.

** - A program to retrofit existing GASS outer legs with the double latch arrangement is underway, during this retrofit period both single and double latch outer legs will be in our stocks. Both options are interchangeable however the separate Safety Latch (code:718907) must be used on all single latch legs when lifting or flying.

A - Before moving the table, the GASS Ledger Frame 1.2 m (code:718020) must be temporarily removed to allow for the arm of the Multi Mover to be operated.



For more information regarding the GASS system including the maximum capacity of the GASS towers, please refer to the current User Guide.

Configuration 6 - Max. Height: 5.50 m

The GASS Leg make-up shown below allows for a maximum table height of 5.90 m, however the table must not exceed a height of 5.50 m when being moved.

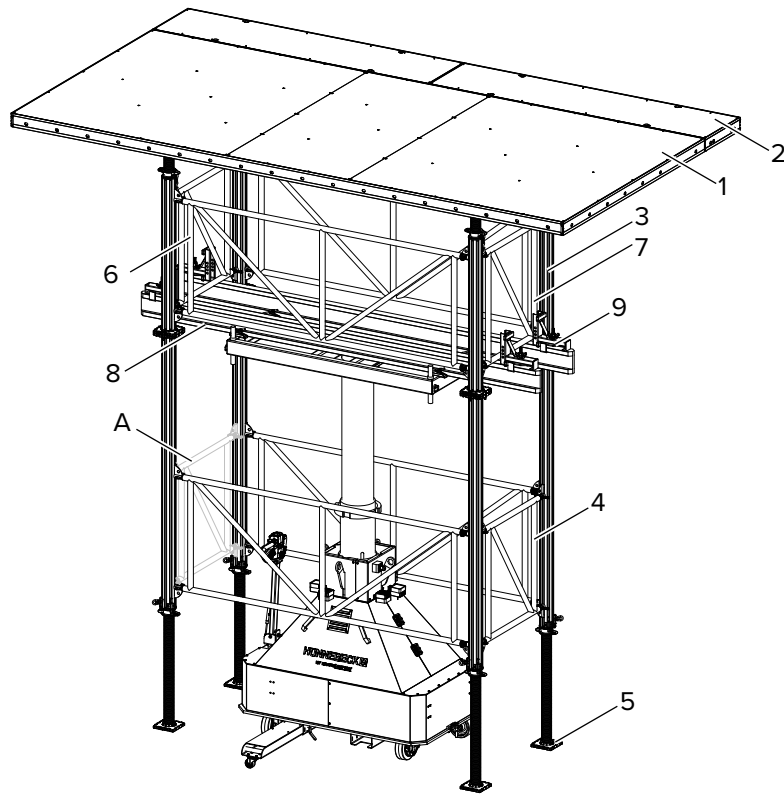

1. TOPMAX Floor Table 2.4 x 5.4 m (code:602586)
2. RASTO Panels (600 mm wide) *
3. GASS Extension Leg 2490 mm (code:718009)
4. GASS Leg 3580 mm (code:718003) **
5. GASS Inner Leg 1450 mm (code:718014)
6. GASS Ledger Frame 3.0 m (code:718023)
7. GASS Ledger Frame 1.2 m (code:718020)
8. H20 Beams 3.60 m (code:581818)
9. Joist Clamping Connector (code:496469)



* - Do not exceed the stated width.

For the connection of RASTO Panels to TOPMAX Floor Table see page 51.

** - A program to retrofit existing GASS outer legs with the double latch arrangement is underway, during this retrofit period both single and double latch outer legs will be in our stocks. Both options are interchangeable however the separate Safety Latch (code:718907) must be used on all single latch legs when lifting or flying.

A - Before moving the table, the GASS Ledger Frame 1.2 m (code:718020) must be temporarily removed to allow for the arm of the Multi Mover to be operated.



For more information regarding the GASS system including the maximum capacity of the GASS towers, please refer to the current User Guide.

6.2 Positioning Unit

Standard assemblies (loading frames) made using components from the MODEX modular scaffold system and 2no. TOPMAX Positioning Units can be used to easily assemble a positioning unit. These units are used with the TOPMAX Floor Tables and meet the requirements of the building site. The units are operated manually and the vertical lifting and lowering as well as the horizontal transport typically requires two persons.

There are 2no. types of positioning units, the TOPMAX Positioning Unit build using the TOPMAX Lifting Jack Carriage (code:603226) and the TOPMAX Positioning Unit 750 build using the TOPMAX Lifting Jack Carriage 750 (code:607111).

For moving and lifting the TOPMAX Floor Tables, the TOPMAX Positioning Unit is placed underneath and centred with the table which is still in the raised position. Use the winches of the TOPMAX Positioning Unit to raise the height and bring the turning heads in contact with the TOPMAX Floor Table.

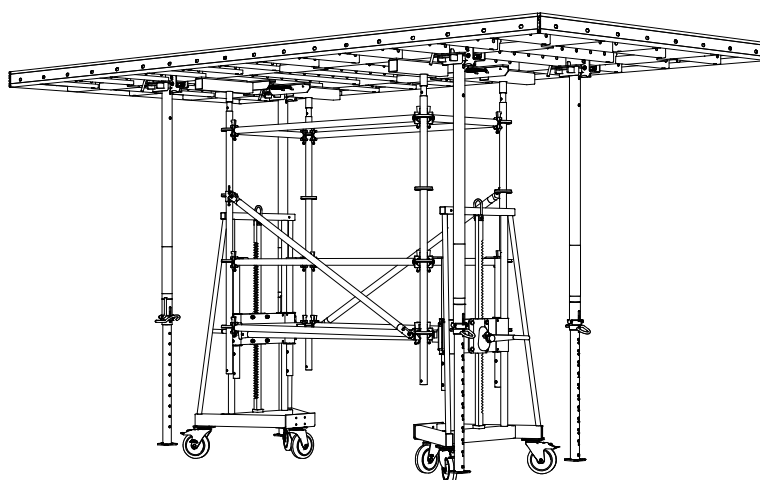

Release the props of the TOPMAX Floor Table using the quick release and slide in the inner tubes to allow the TOPMAX Positioning Unit to reach its lowest position. The integrated winches of the TOPMAX Positioning Unit allow a vertical adjustment range of 0.93 m.

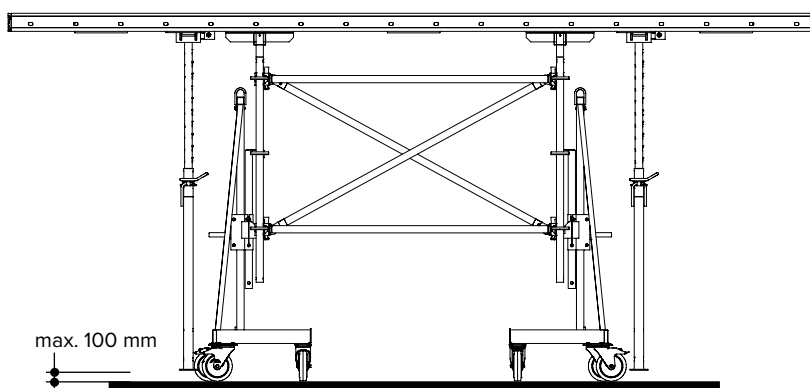

In all cases the Positioning Units must be placed centrally under the table. All loads to be carried must be evenly distributed.
Tables must be lowered as low as possible before moving.
Props must have a maximum floor clearance of 100 mm.



For more information regarding the TOPMAX Positioning Unit, including assembly, operation and transport, refer to the separate Operating Instructions.

6.2.1 TOPMAX Positioning Unit

The TOPMAX Positioning Unit is build using the 2no. TOPMAX Lifting Jack Carriage (code:603226) with a MODEX Assembly Type 1 (schedule shown below) and is used to lift tables no higher than 3.00 m.

Safe Working Loads:

- 10.00 kN (per trolley)
- 20.00 kN (per Positioning Unit)

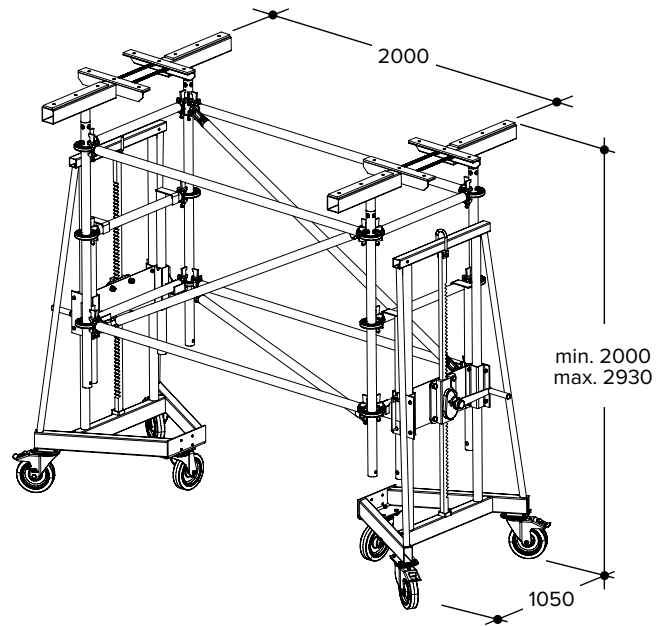

The MODEX Assembly Type 1 (loading frame) is made of the following components:

Component	Quantity	Part code
TOPMAX Lifting Jack Carriage	2	603226
TOPMAX Turning Head	4	603237
TOPMAX Readjusting Spring	4	603303
Tube Ledger 82	4	470930
Tube Ledger 200	4	475781
Vertical Post 150	4	470881
V-diagonal 100/200	2	651659
H Diagonal 200/82	2	651623
Shear Force Securing Device	16	577988

The total weight of the assembly is 334.46 kg.



WARNING

Risk of damage, collapse and/or serious injury!

TOPMAX Floor Tables higher than 3.00 m must only be moved with the TOPMAX Positioning Unit 750 or the Multi Mover (code:607150).

6.2.2 TOPMAX Positioning Unit 750

The TOPMAX Positioning Unit 750 is build using the 2no. TOPMAX Lifting Jack Carriage 750 (code:607111) with several types of MODEX Assemblies.
Safe Working Load: TOPMAX table 2.4 x 5.4 m = 13.10 kN (for table and MODEX frame).

TOPMAX Positioning Unit 750 Type 1 (2.00 m to 2.95 m)

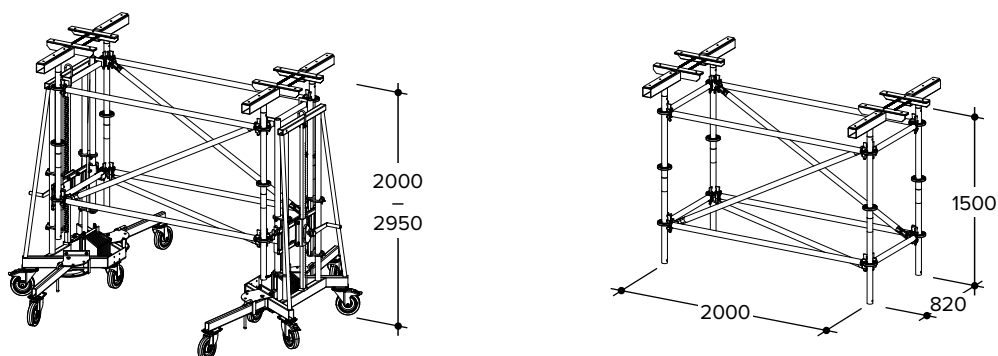

Component	Quantity	Part code
TOPMAX Lifting Jack Carriage 750	2	607111
TOPMAX Turning Head	4	603237
TOPMAX Readjusting Spring	4	603303
Tube Ledger 82	4	470930
Tube Ledger 200	4	475781
Vertical Post 150	4	470881
V-diagonal 100/200	2	651659
H Diagonal 200/82	2	651623
Shear Force Securing Device	16	577988

The total weight of the assembly is 578.84 kg.

TOPMAX Positioning Unit 750 Type 2 (2.37 m to 3.44 m)

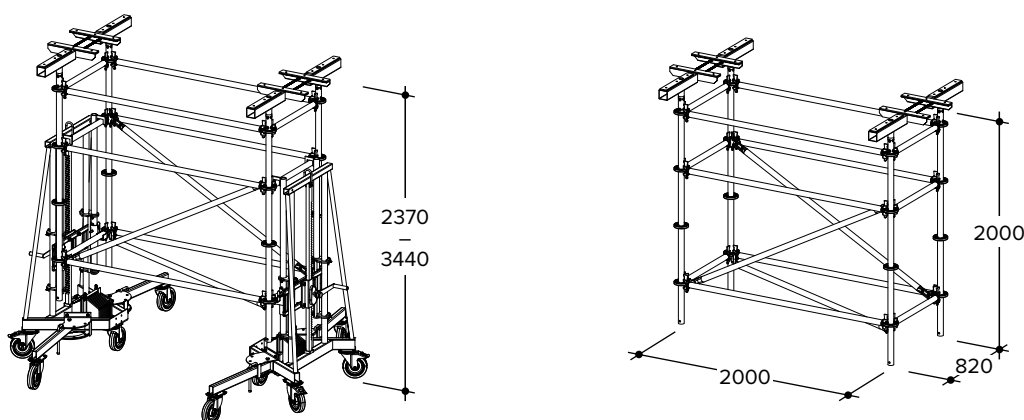

Component	Quantity	Part code
TOPMAX Lifting Jack Carriage 750	2	607111
TOPMAX Turning Head	4	603237
TOPMAX Readjusting Spring	4	603303
Tube Ledger 200	6	475781
Tube Ledger 82	6	470930
Vertical Post 200	4	470892
V-diagonal 100/200	2	651659
H Diagonal 200/82	1	651623
Shear Force Securing Device	24	577988

The total weight of the assembly is 613.10 kg.

TOPMAX Positioning Unit 750 Type 3 (3.37 m to 4.44 m)

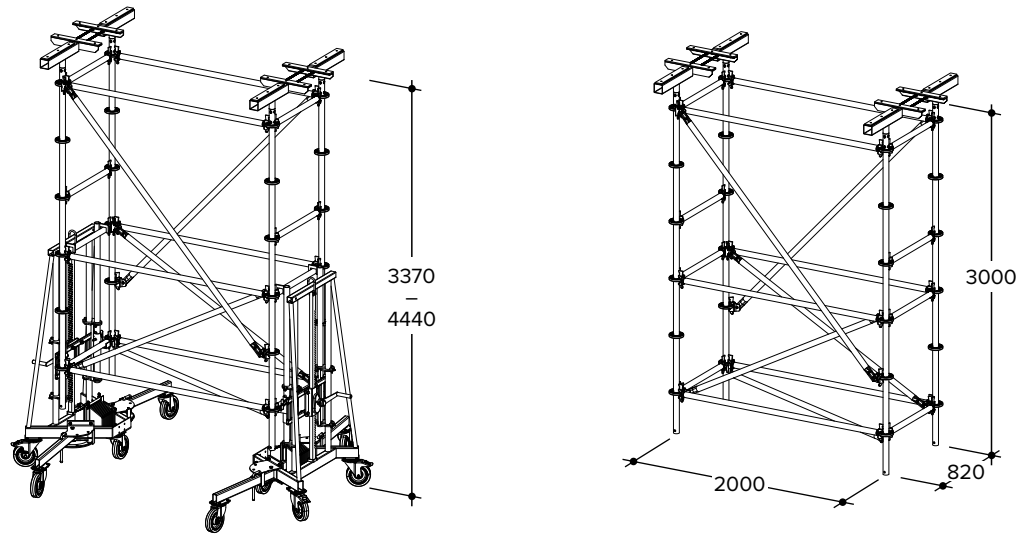

Component	Quantity	Part code
TOPMAX Lifting Jack Carriage 750	2	607111
TOPMAX Turning Head	4	603237
TOPMAX Readjusting Spring	4	603303
Vertical Post 300	4	470907
Tube Ledger 82	8	470930
Tube Ledger 200	6	475781
V-diagonal 200/200	2	475910
V-diagonal 100/200	2	651659
H Diagonal 200/82	1	651623
Shear Force Securing Device	28	577988

The total weight of the assembly is 664.62 kg.

TOPMAX Positioning Unit 750 Type 4 (4.37 m to 5.44 m)

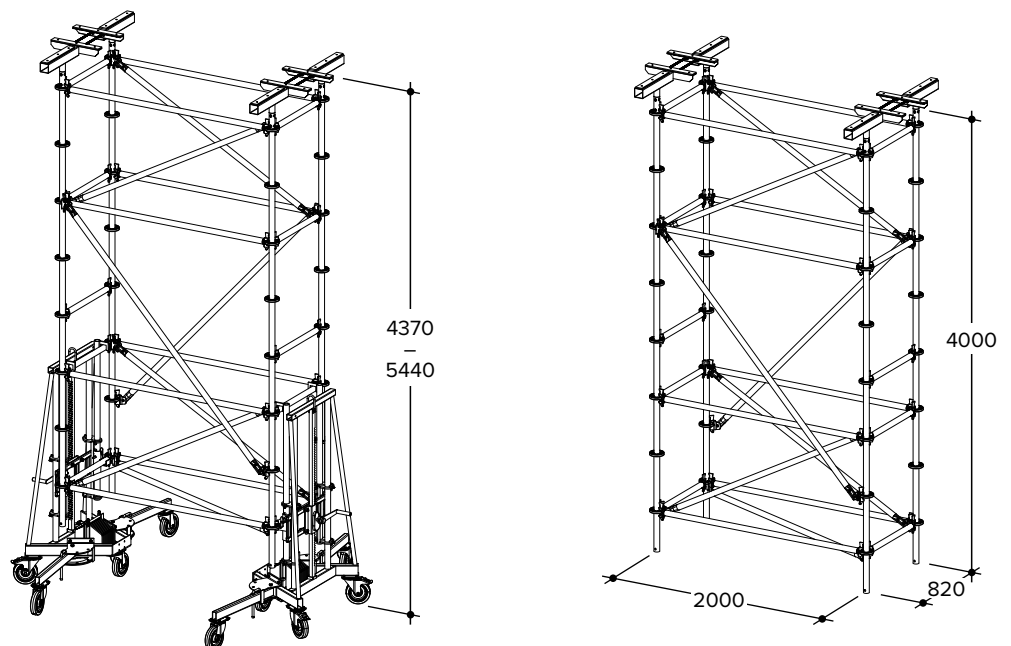

Component	Quantity	Part code
TOPMAX Lifting Jack Carriage 750	2	607111
TOPMAX Turning Head	4	603237
TOPMAX Readjusting Spring	4	603303
V-diagonal 100/200	4	651659
Tube Ledger 82	10	470930
Vertical Post 400	4	470918
Tube Ledger 200	8	475781
V-diagonal 200/200	2	475910
H Diagonal 200/82	1	651623
Shear Force Securing Device	36	577988

The total weight of the assembly is 728.10 kg.

TOPMAX Positioning Unit 750 Type 5 (3.41 m to 4.48 m + 2.00 m Extension Frames)

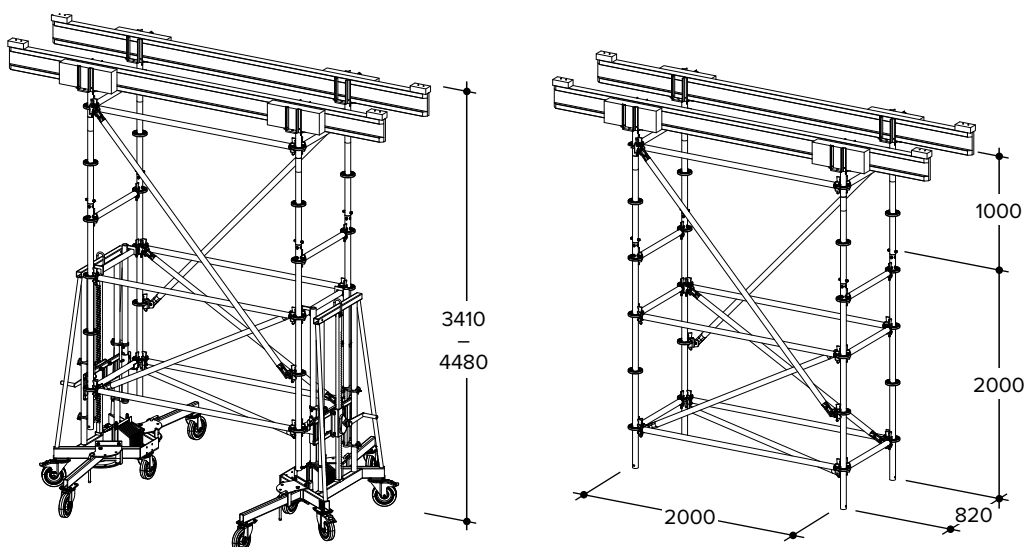

Component	Quantity	Part code
TOPMAX Lifting Jack Carriage 750	2	607111
H 20 K-Beam 390 to move longitudinally under scaffold or H 20 K-Beam 190 to move laterally under scaffold	2	603195 603190
Crosshead Jack 70/3.8×6.3	4	652184
Vertical Post 100 L	4	553645
Screw M12x75 with nut	4	554710
Tube Ledger 82	8	470930
Vertical Post 200	4	470892
Tube Ledger 200	6	475781
V-diagonal 200/200	2	475910
V-diagonal 100/200	2	651659
H Diagonal 200/82	1	651623
Shear Force Securing Device	28	577988

The total weight of the assembly is 701.70 kg.

TOPMAX Positioning Unit 750 Type 6 (4.41 m to 5.48 m + 2.00 m Extension Frames)

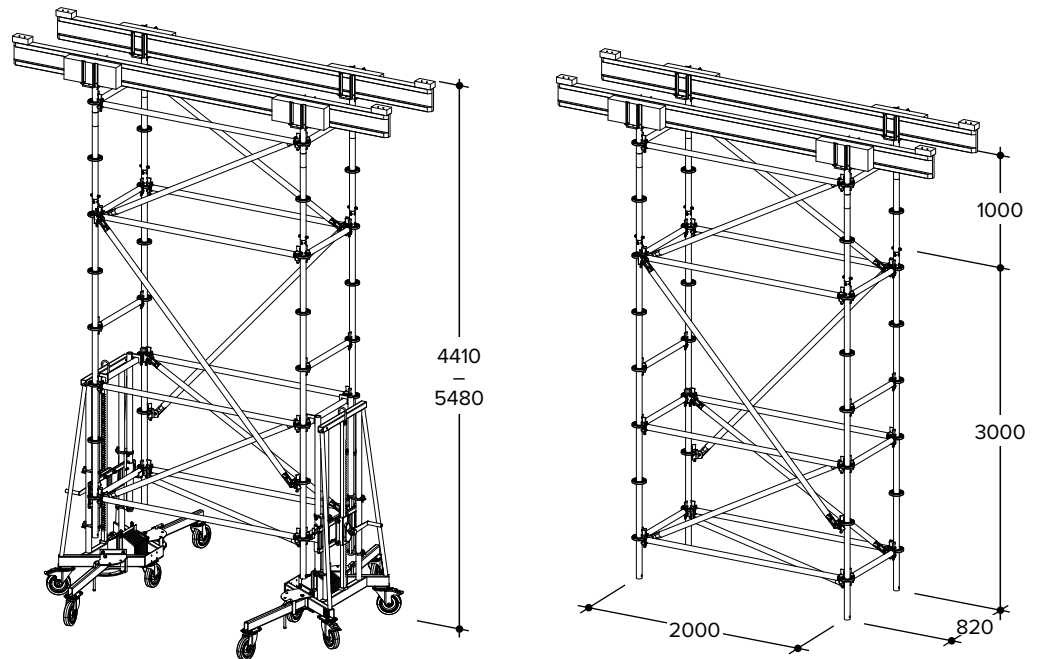

Component	Quantity	Part code
TOPMAX Lifting Jack Carriage 750	2	607111
H 20 K-Beam 390 to move longitudinally under scaffold or H 20 K-Beam 190 to move laterally under scaffold	2	603195 603190
Crosshead Jack 70/3.8×6.3	4	652184
Vertical Post 100 L	4	553645
V-diagonal 100/200	4	651659
Screw M12×75 with nut	4	554710
Tube Ledger 82	10	470930
Vertical Post 300	4	470907
Tube Ledger 200	8	475781
V-diagonal 200/200	2	475910
H Diagonal 200/82	1	651623
Shear Force Securing Device	36	577988

The total weight of the assembly is 765.34 kg.

TOPMAX Lifting Carriage 750 with GASS towers

TOPMAX Table Forms with GASS shoring systems up to 7.50 m high can be moved with two TOPMAX Lifting Jack Carriages. Two persons are needed to operated the two Lifting Jack Carriages, one person for each Lifting Jack Carriage.



WARNING

Risk of tipping over when GASS frames are loose!

The TOPMAX table can tip over as it is lifted if the GASS frames are not properly secured!

This can cause personal injury or death!

Before lifting, check that all wedge connections at the lower level of the GASS frames are properly locked!



For more information regarding the TOPMAX Positioning Unit, including assembly, operation and transport, refer to the separate Operating Instructions.



To be able to move the Lifting Jack Carriage 750 under the GASS frames, the GASS frames (lower edge) have to be 0.59 m - 1.50 m off the ground. Once the GASS frames have been connected to the Lifting Jack Carriage, the GASS assembly can be lowered to 0.55 m from the ground.

The adjustment range (lift) of the trolley is 0.55 m –1.62 m.

Safe Working Loads:

- GASS Tower w/ table 2.4 x 5.4 m: 8.00 kN.

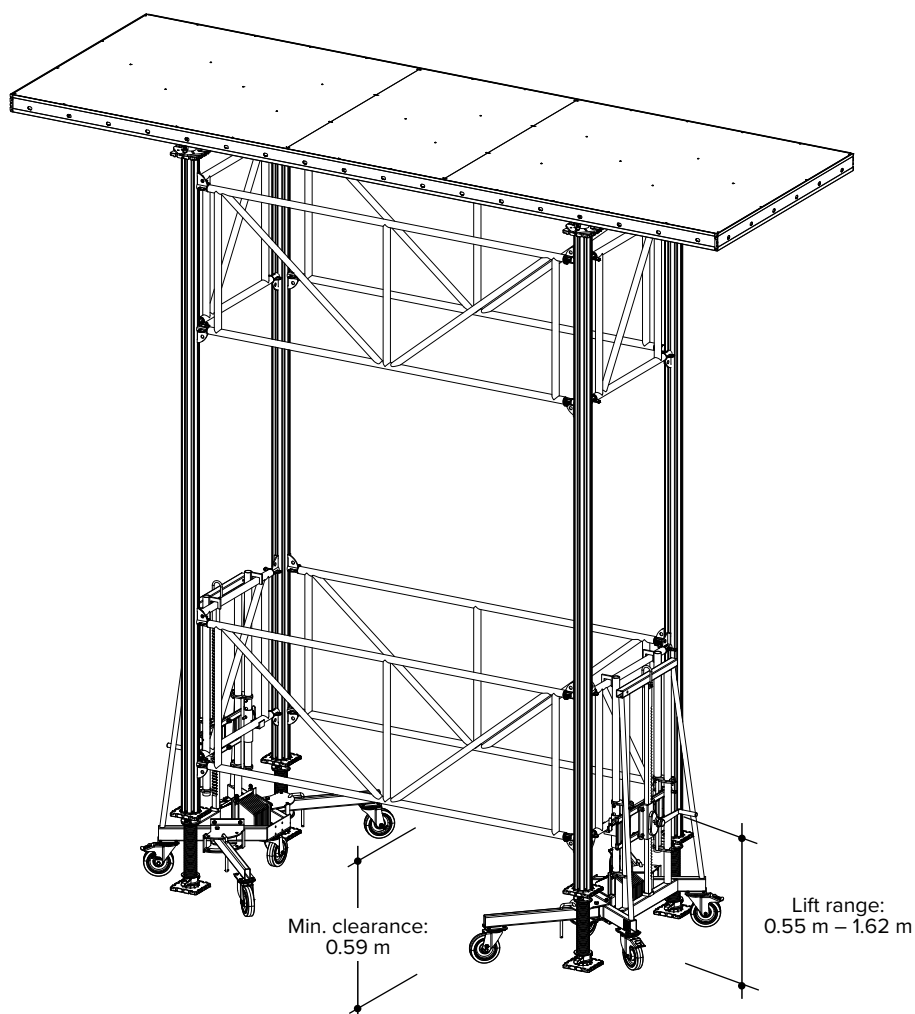

6.3 TOPMAX Electric Table Jack Lift

With the TOPMAX Electric Table Jack Lift (code:603600) TOPMAX Floor Tables can be lifted, horizontally transported and precisely positioned.

Main features

- Operated by only one person
- Max. load: 12.50 kN
- The capacity of a fully charged battery allows a normal operation time of 8 to 10 hours.
- Integrated battery charger (230 Volts)
- Defined safe pick points for the crane
- Built in safety devices
- Motorized positioning mechanism for precise positioning of the tables in cross direction.

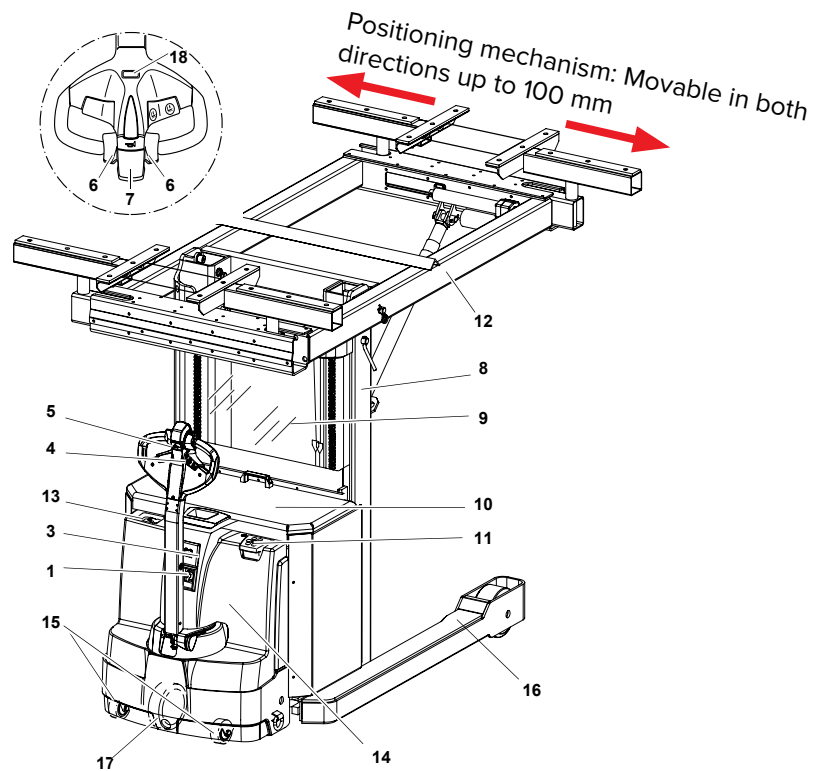

Pos.	Description	Pos.	Description
1	Power circuit-breakers	11	Emergency switch
3	Charge level indicator	12	Lifting table
4	Shaft with shaft head	13	Battery charger
5	Button slow running	14	Front hood
6	Speed control	15	Stabilizer wheels
7	Collision safety button	16	Wheel arm
8	Lifting beam	17	Drive wheel
9	Protective glass	18	Side shifting device
10	Battery cover		

After driving through the props place the lifting table centered under the floor table. Use the marking for the center of gravity and the turning heads on the jack lift side as reference points. Adjust the marking for the centre of gravity to the centre of the floor table. The distances to the edges have to be as equal as possible.

F = 1250 kg
Center of gravity marker

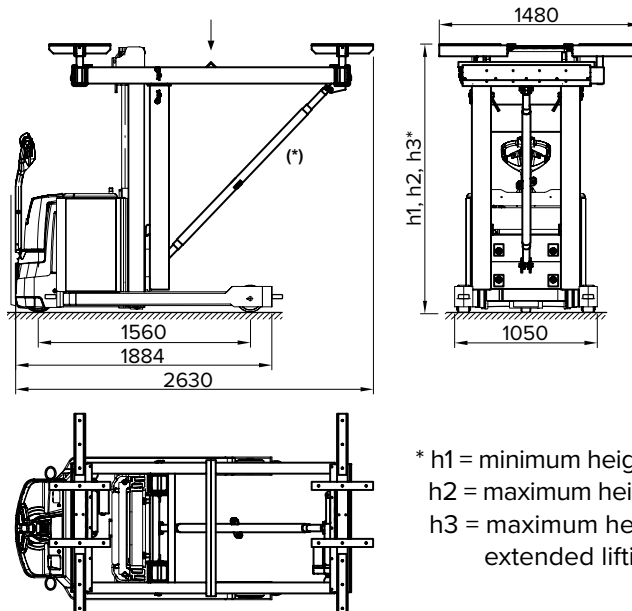

* h1 = minimum height above turning heads = 1,98 m
h2 = maximum height above turning heads = 4,48 m
h3 = maximum height above turning heads with extended lifting device = 5,38 m

WARNING

Warning!
Follow the separate operating instructions of the TOPMAX Electric Table Jack Lift.

If the two rear turning heads are used for aligning these are placed underneath the next cross rib behind the props.

NOTE

Note!
In this position, the marking of the center of gravity is exactly centric underneath the formwork.

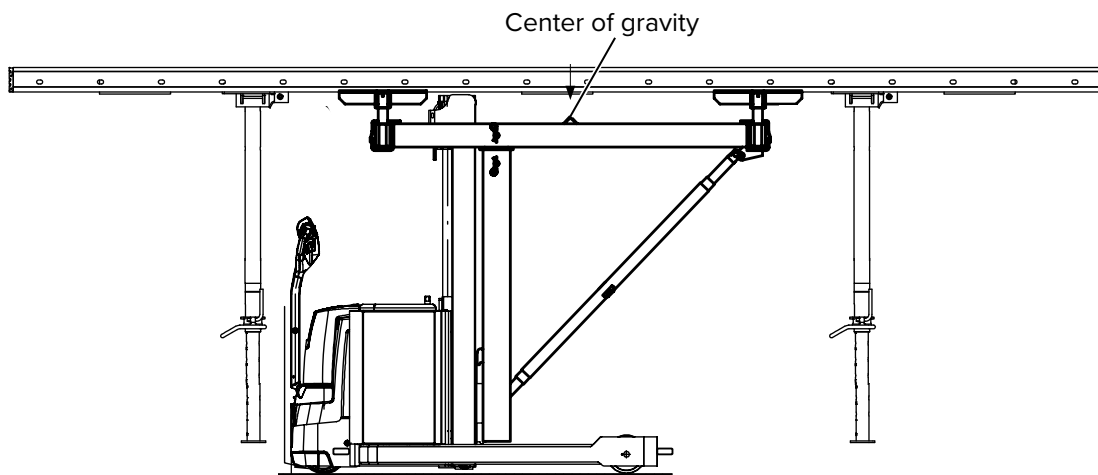

Min. height: 1,98 m
Max. height: 5,38 m

NOTE

Note!
To reach the highest position the lifting table must be extended. See the separate operating instructions of the TOPMAX Electric Table Jack Lift.

6.3.1 Transport of floor tables with extension frames

To transport the extension frame remove the turning heads and equip the TOPMAX Electric Table Jack Lift with the following additional parts as shown:

2no. TOPMAX EHW H 20 Table Carrier (code:603568)

2no. H 20 Beam 3.90 m (code:581829)

4no. H 20 Timber Beam Clamp (code:568048)

4no Joist Clamping Connectors (code:496469). Connectors not shown, see step 3 of page 126.

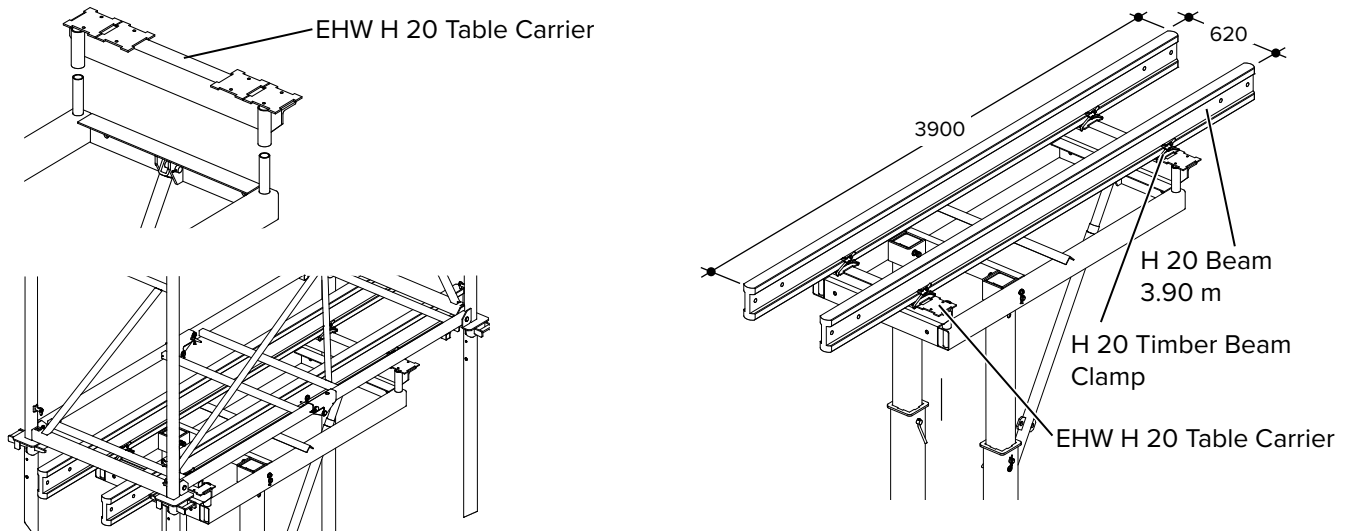

With this assembly it is also possible to pass the props with the table jack lift to pick up the table.



WARNING

Warning!

For transport lower tables max. Only pick up and transport single tables!

After picking up the table push in the props to allow the maximum lowering of the table jack lift.

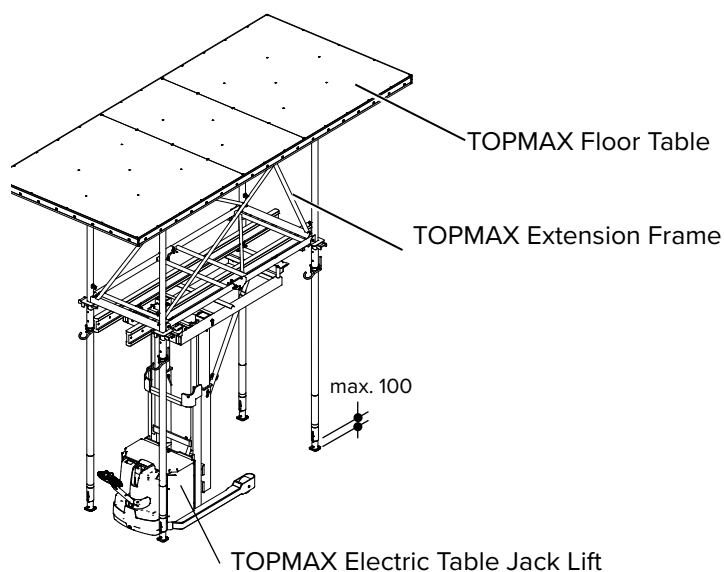

WARNING

Warning!

The ground clearance of the props during transport has to be limited to max. 100 mm!

7 Lifting

7.1 TOPMAX Crane Suspension

The TOPMAX Crane Suspension (code:603050) is use for loading and unloading of stacked TOPMAX Floor Tables and for the transport of single tables on site.

The Working Load Limit of the TOPMAX Crane Suspension is 5.00 kN.

TOPMAX Crane Suspension

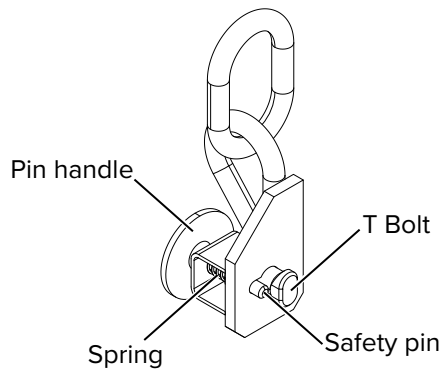

The attachment points (holes) must be in a safe and faultless condition. To crane lift TOPMAX Floor Tables, 4no. TOPMAX Crane Suspension (code:606050) attached to the long outer profile of the TOPMAX Floor Table are required. The maximum distance between attachment points is 2.70 m and the minimum distance is 2.10 m, equally distanced from both ends of the profile and symmetrical to the other side. This arrangement must be done in such a way that the self weight of the tables is evenly distributed between the attachment points.

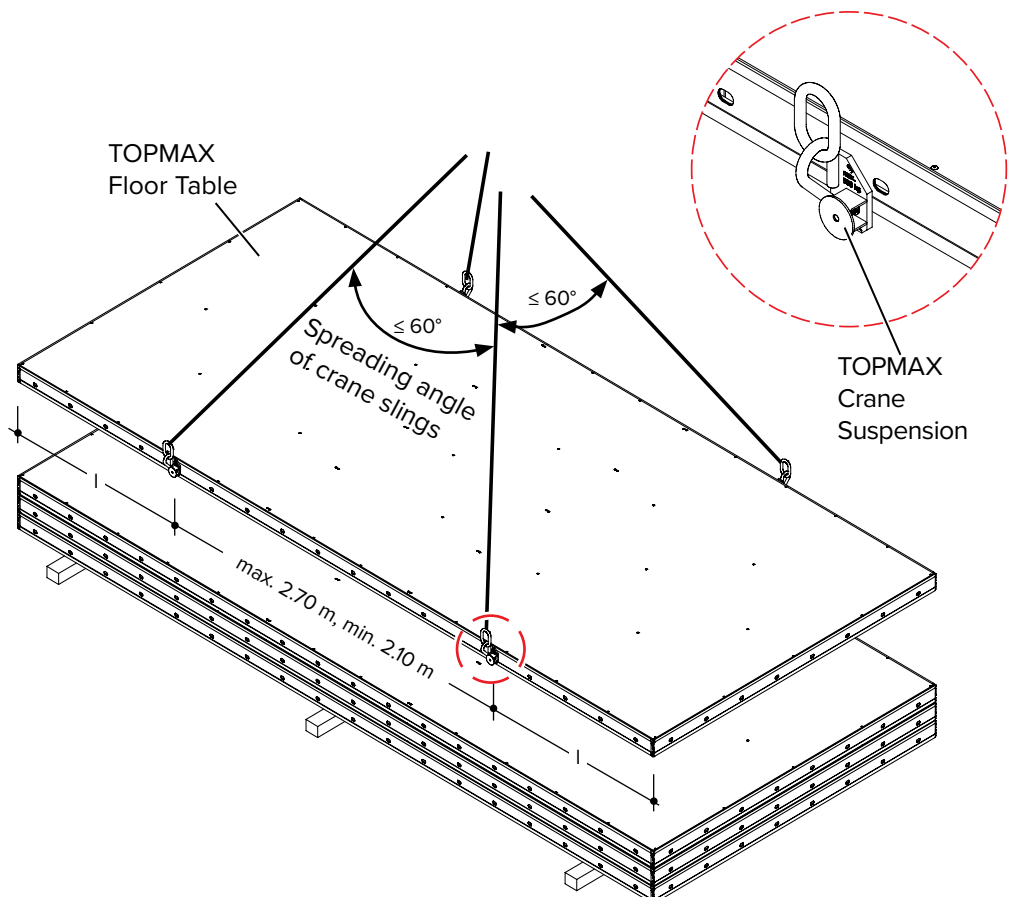

- Step 1** Align the T bolt of the TOPMAX Crane Suspension (code:603050) with the required hole position. See notes on page 145.

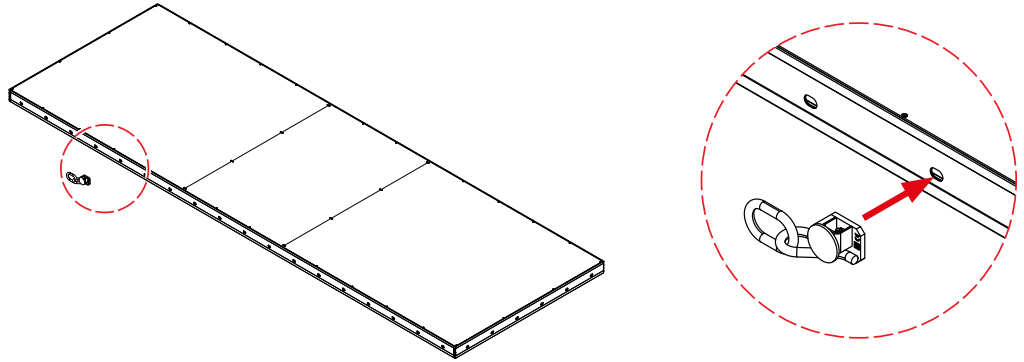

- Step 2** Insert the T bolt on the hole position. Push to ensure that the safety pin retracts.

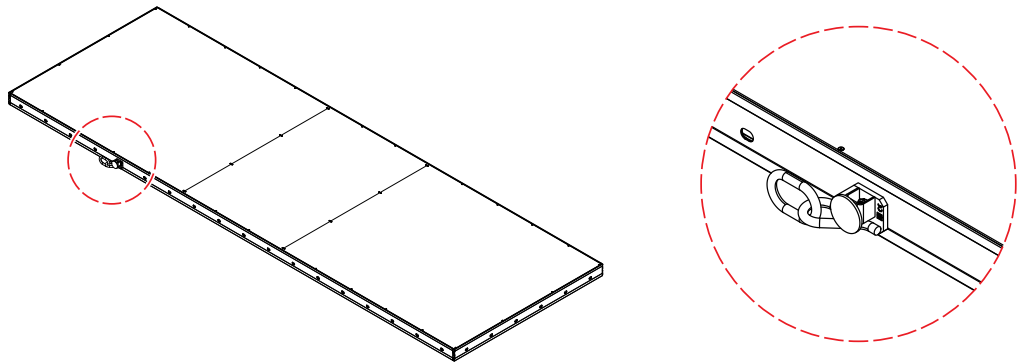

- Step 3** Rotate the TOPMAX Crane Assembly (code:603050) until the safety pin springs into the hole. A "click" sound will be audible and it will signal that the pin has been pushed out.

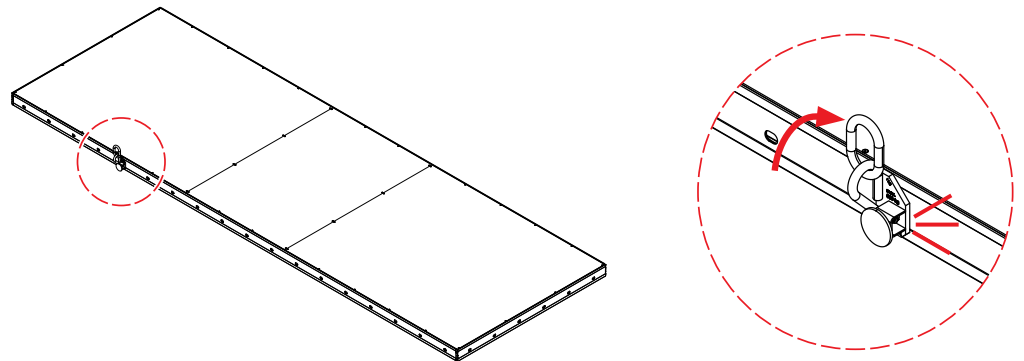

The safety bolt of the TOPMAX Crane Suspension (code:603050) needs to lock in clearly. If it doesn't, the TOPMAX Crane Suspension (code:603050) must be shifted to the left. When the TOPMAX Crane Suspension (code:603050) is connected, a function test is to be done (turning) to ensure the shape of the slotted hole is not damaged and the TOPMAX Crane Suspension (code:603050) is engaged correctly.

Dismantling the TOPMAX Crane Suspension

- Step 1** Pull and hold the round pin handle to allow for the pin to retract enough so that the TOPMAX Crane Suspension (code:603050) can rotate.
- Step 2** Rotate the TOPMAX Crane Suspension (code:603050) to the horizontal position.
- Step 3** Pull the TOPMAX Crane Suspension (code:603050) out of the hole position.



For more information regarding the TOPMAX Crane Suspension, refer to the separate Operating Instructions.



WARNING

Risk of damage, collapse and/or serious injury!

Never use the TOPMAX Crane Suspension attached to the shorter outer profile. TOPMAX Floor Tables are to be lifted as a single panel or as a bundle of no more than 4no. panels.

When lifting more than one panel, the units must be banded together.

If a bundle of TOPMAX Floor Tables is to be lifted, always attach the TOPMAX Crane Suspension to the panel at the bottom of the bundle.

Never transport connected TOPMAX Floor Tables.

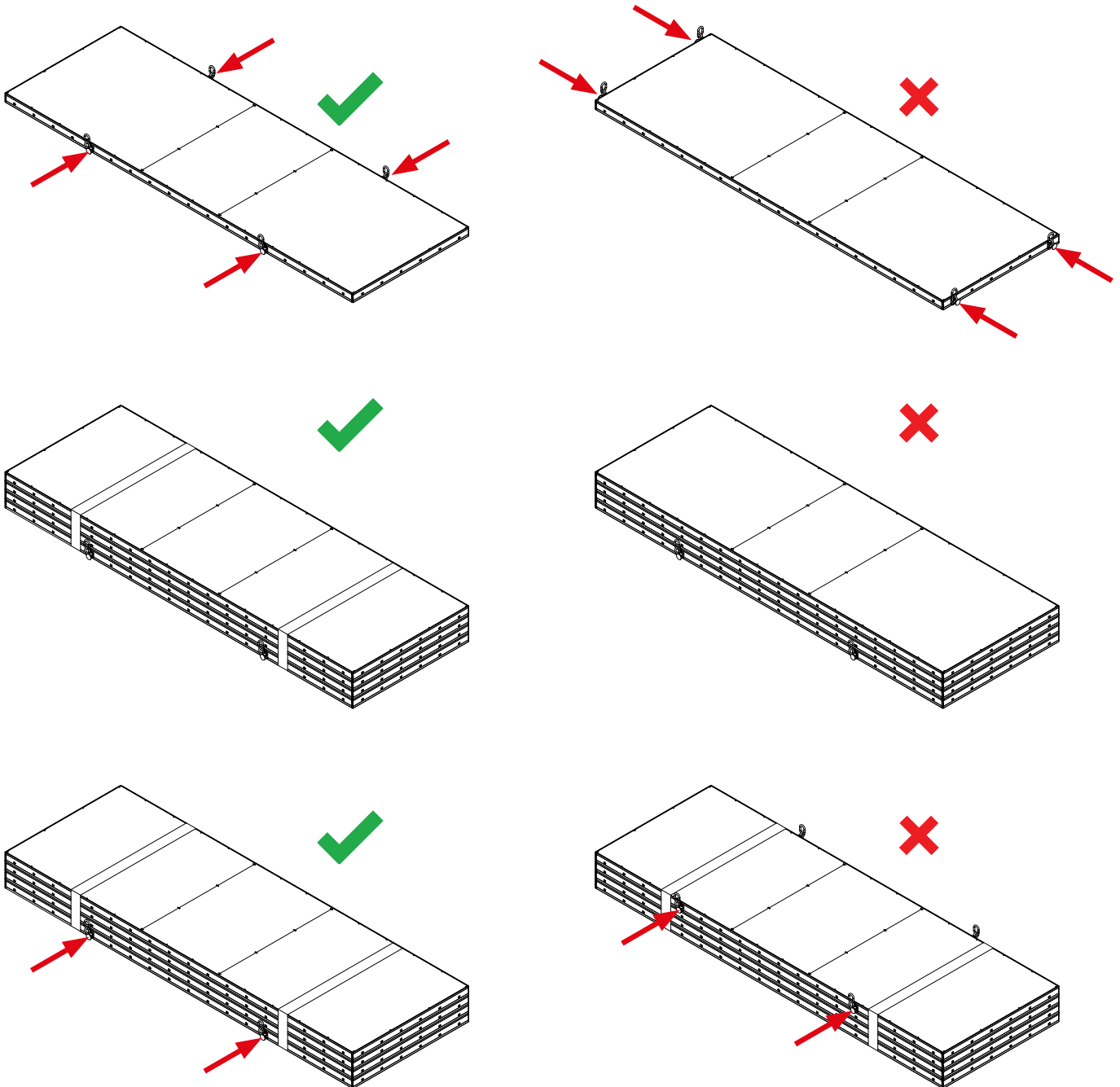

7.2 TOPMAX Lifting Fork

Transporting TOPMAX Floor Tables by crane using the TOPMAX Lifting Fork (code:603074) is easy, safe and very efficient. In this way, the TOPMAX Floor Tables are optimally transported horizontally and vertically on site.

When stripping the formwork the transport out of the building is also easy to handle.

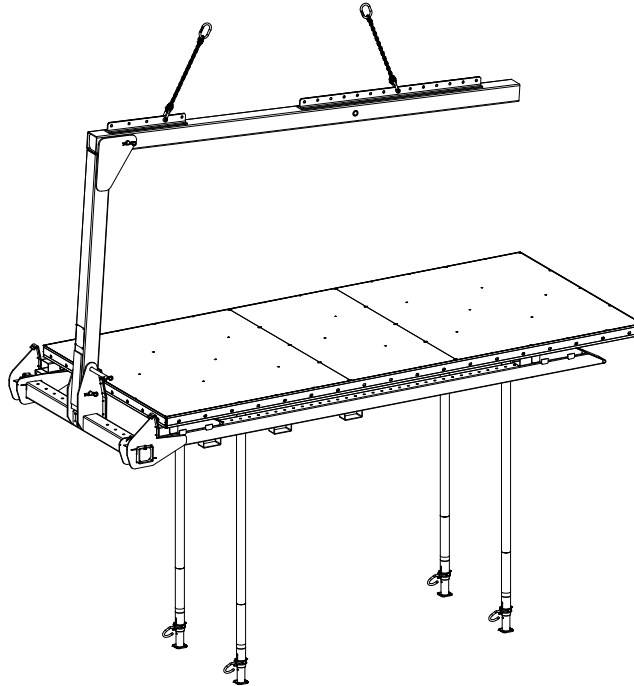

The TOPMAX Floor Table can be lifted from the short side as well as from the long side.

1

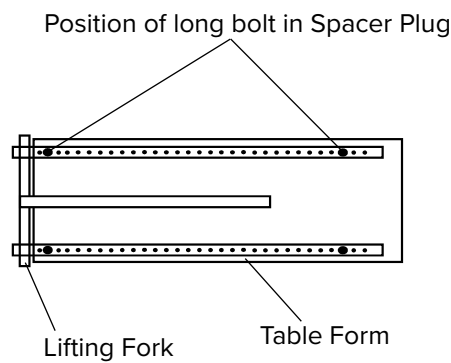

2

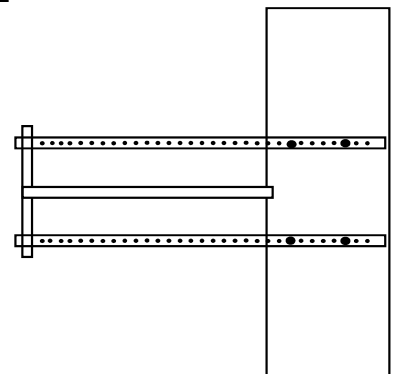

3

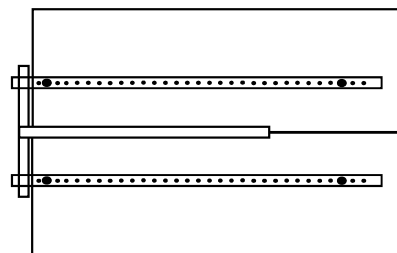

4

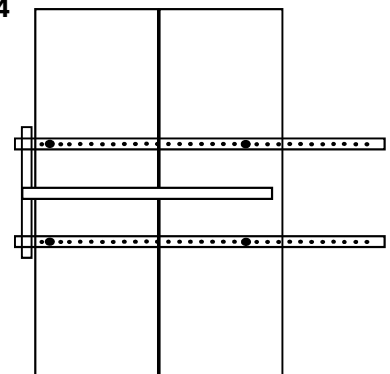

For more information regarding the TOPMAX Lifting Fork (code:603074), including assembly, operation and transport, refer to the separate Operating Instructions.

WARNING

Risk of damage, collapse and/or serious injury!

The TOPMAX Lifting Fork (code:603074) must be folded when stored temporarily on site, as shown below. This can be achieved regardless of the vertical post used on the fork.

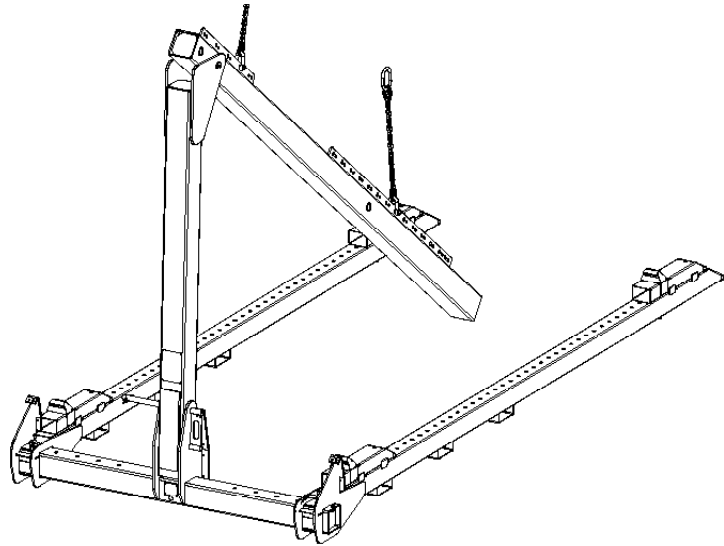

Vertical Post 600

The UG Vertical Post 600 (code:603596) is an accessory of the TOPMAX Lifting Fork (code:603074) and replaces the standard UG Vertical Post (code:603079). It is used when the opening width of the standard TOPMAX Lifting Fork (code:603074) is not sufficient to access floor tables from above, for example at double floors.

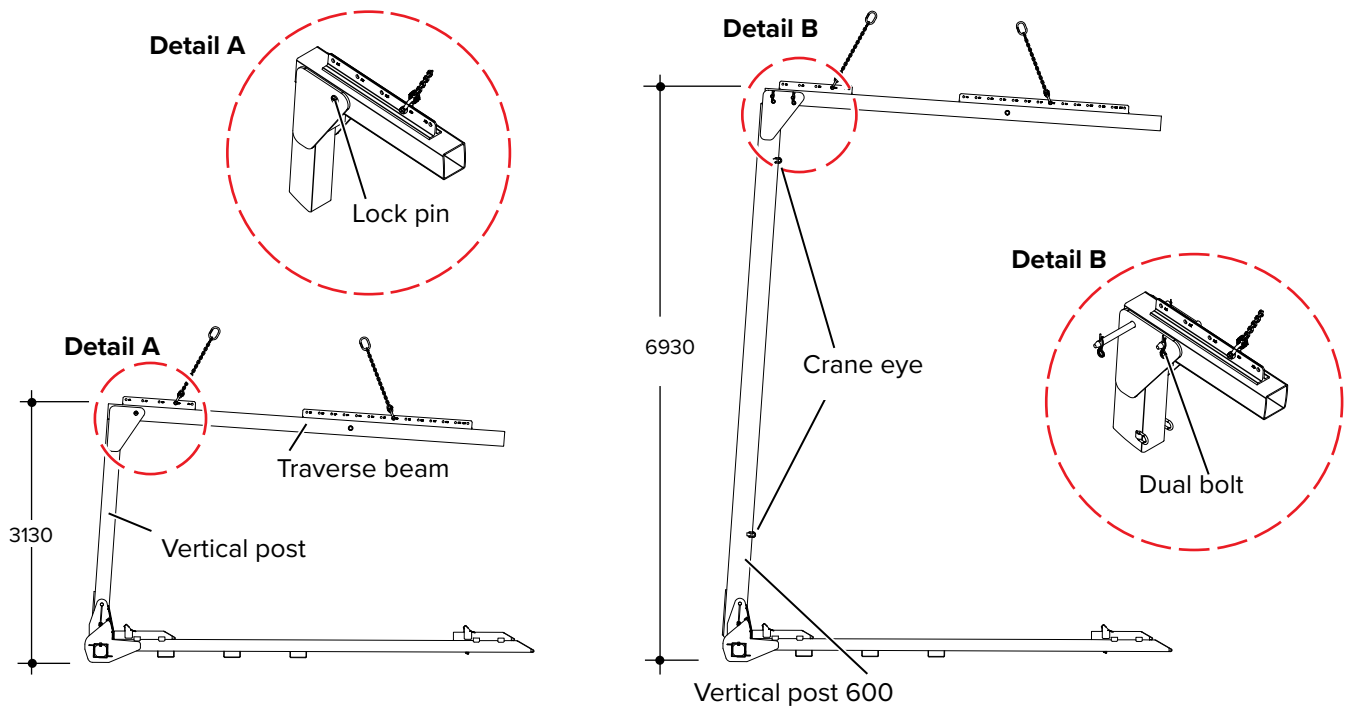

Technical data	With	
	Vertical Post	Vertical Post 600
Working Load Limit	12.50 kN	12.50 kN
Self weight	9.00 kN	12.00 kN
Total weight	21.50 kN	24.50 kN

7.3 TOPMAX Table Lifting System

The TOPMAX Table Lifting System (code:603500) is a crane-free system used to lift the TOPMAX Floor Tables and it can be used to reach working heights of 50.00 m, after which it can also be used as a drive out platform for the TOPMAX Floor Tables.

The TOPMAX Table Lifting System (code:603500) is a modular construction system, which can be adapted quickly and flexibly to the requirements of the building. This system consists of a basic unit (basic frame with drive, control and three-part hoisting cage), single triangle lattice tower elements, pylon ties for the connection to the building, floor gates and connection cables. The TOPMAX Table Lifting System (code:603500) is loaded with the TOPMAX Electric Table Jack Lift (code:603600) or the TOPMAX Positioning Unit.

The system is controlled, depending on the operation mode, from the ground station, the floor gates or the hoisting cage.



When using the TOPMAX Table Lifting System (code:603500) to transport people, the system must be operated from the transport cage.



WARNING

Risk of damage, collapse and/or serious injury!

Do not exceed the maximum load-bearing capacity of the TOPMAX Table Lifting System (code:603500).

Maximum load-bearing capacity during transport: 1,685 kg.

Maximum load-bearing capacity during loading/unloading: 2,370 kg.

Do not operate the TOPMAX Table Lifting System (code:603500) with wind speeds above 72 Km/h (8 Bft).



Follow the separate operating instructions and Product Information no. 203 of the TOPMAX Table Lifting System (code:603500).

Detail B

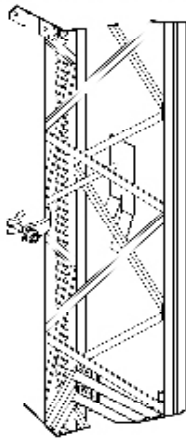

Detail A

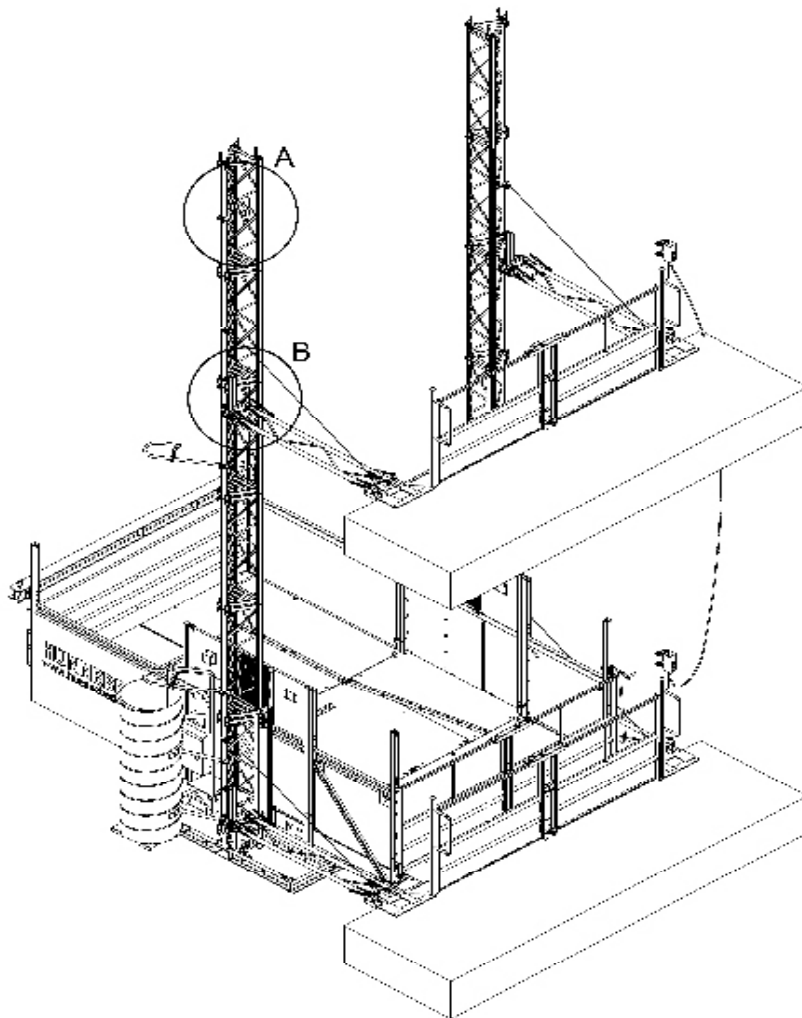
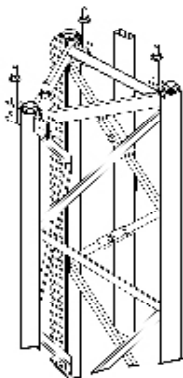

Inner dimensions of platform: 5.11 m x 2.93 m

8 Notes on structural analysis

Unless explicitly stated otherwise, all load specifications in this document are safe working loads. This means that characteristic loads can be used for calculations. The following safety factors are included in the safe working load (where applicable):

Load:

$$\gamma_f = 1.5$$

According to DIN EN 1991-1-1 / DIN EN 1991-1-1

Resistances:

$$\text{Steel: } \gamma_m = 1.1$$

Imperfections, load assumptions and additional rules:

According to DIN EN 1993 / DIN EN 12810 / DIN EN 12811/ DIN EN 12812 / DIN EN 1991

Aluminum:

$$\gamma_m = 1.1$$

Imperfections, load assumptions and additional rules:

According to DIN EN 1999 / DIN EN 12810 / DIN EN 12811 / DIN EN 12812 / DIN EN 1991

Timber:

$$\gamma_m = 1.3$$

$$K_{\text{mod}} = 0.9$$

Imperfections, load assumptions and additional rules:

According to DIN EN 1995 / DIN EN 12810 / DIN EN 12811 / DIN EN 12812 / DIN EN 1991

Concrete:

$$\gamma_m = 1.5$$

Imperfections, load assumptions and additional rules:

According to DIN EN 1992 / DIN EN 12810 / DIN EN 12811 / DIN EN 12812 / DIN EN 1991

Concrete steel:

$$\gamma_m = 1.15$$

Imperfections, load assumptions and additional rules:

According to DIN EN 1992 / DIN EN 12810 / DIN EN 12811 / DIN EN 12812 / DIN EN 1991

These values only include those loads that derive from the respective part itself (unless stated otherwise).

An increase of the loads due to effects in the full system (e.g. theory II, substitute horizontal loads, scaffolding class...) have to be considered.

9 Chronology

Changes since edition 2018-09	Page	Date
Multi Mover (code:607150) included (a)	111	2022-01
Panel Anchor Bracket (code:605999) included (b)	81	2022-01

(a) - The Product Information 1006 Multi Mover EN 2021-04-09 has been incorporated in this document.

(b) - The Product Information 1001 Panel Anchor Bracket EN 2021-04-23 has been partially incorporated in this document.

Hünnebeck in the UK

Rush Lane, Dosthill
 Tamworth, West Midlands, B77 1LT
 Tel.: +44 (0) 1827 289 955
 info-uk@huennebeck.com
 www.huennebeck.de

The contents of this document, including without limitation, the products, design, images, text, trademarks, service marks and logos contained herein, are protected by copyright and other intellectual property rights. No rights or licences are granted.

The contents of this document are not to be reproduced mechanically, electronically or otherwise, including for distribution, sale or display without our written permission.

The illustrations, processes, materials and/or information in this document are for general information only on the basis that conditions and procedures may differ. No representation, warranty or guarantee is made or implied, including in relation to the fitness or suitability of the product. Overviews and diagrams are for illustrative purposes only.

Specifications may vary and BrandSafway reserves its rights to vary specifications, procedures, and materials due to continuous development, or when required to comply with new regulations, other safety guidance's or industry advancements. The processes set out in the documents should only be undertaken by qualified authorised personnel. The information contained in this document is for use for the applicable product, obtained directly from us.

We may also issue safety notes on products or packaging where required. These notices may affect the manner in which products are used and should therefore be adhered to. The most recent published notice should prevail.

Performance, procedures and results may differ based on actual site conditions.

The aforementioned statements do not seek to limit our liability for fraud, or for personal injury or death caused by our negligence. However, we will not be liable for any damage to property, personal injury or any losses caused by failure to follow the instructions contained in our material. It remains the responsibility of the user to comply with the applicable legislation.

Supply of this product is subject to our terms and conditions. For more information, including on the specification, our terms and conditions/terms of business and for installation and dismantling procedures, please contact us.

© 2022 Hünnebeck GmbH. All rights reserved

Last modified January 2022
Keep for later use!